

K'NEX®

14136

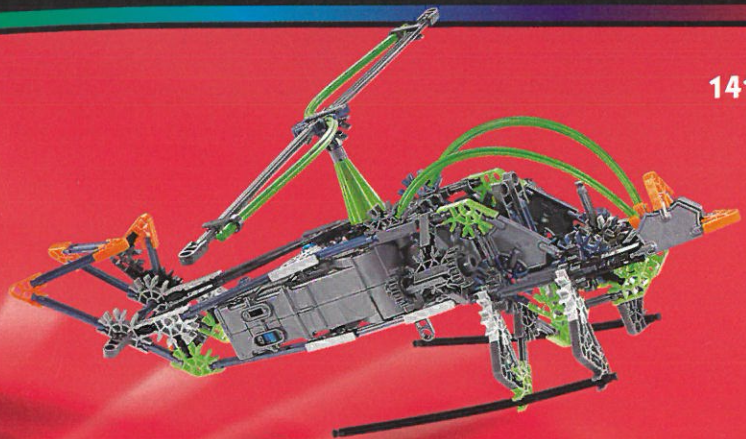
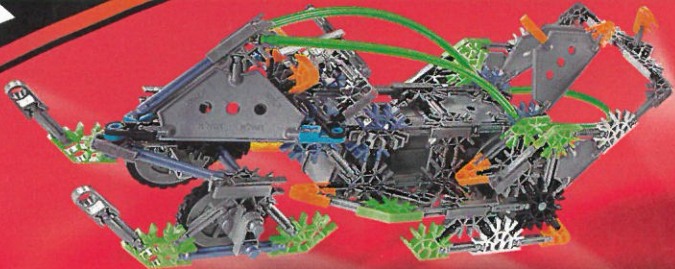

COOL MACHINES

BUILDING SET **8** MODELS

WARNING:
CHOKING HAZARD – Small Parts.
Not for children under 3 years.

AVERTISSEMENT:
DANGER D'ÉTOUFFEMENT – Pièces de petite taille.
Ne pas donner aux enfants de moins de 3 ans.

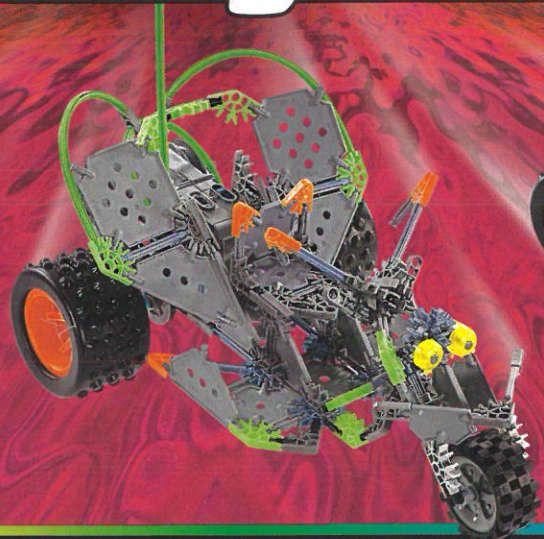
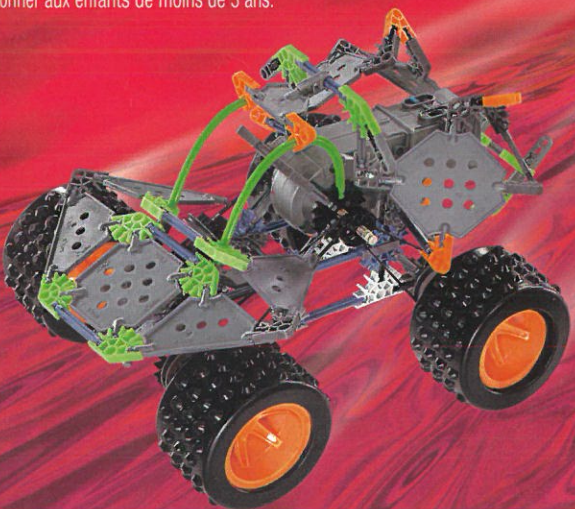

ATENCIÓN:
PELIGRO DE ASFIXIA – Por contener piezas pequeñas,
no recomendable para niños menores de tres años.



Congratulations!

You have discovered K'NEX, the award winning construction system that lets you build and bring to life anything you can imagine.

Stretch your imagination. Make the most of your creativity. And have a ton of fun building, too.

Your set has everything you need to turn K'NEX parts into totally cool models. The instructions get you going, but the fun doesn't stop there. Design your own models! Make your own K'NEX world.

And check out the other great K'NEX Sets, with exciting themes and models for kids of all ages!

Visit the K'NEX Web site at www.knex.com. Questions? Call us at 1-800-KID-KNEX.

Félicitations ! Vous venez de découvrir K'NEX, un système de construction unique qui vous permettra de créer tout un monde imaginaire.

Laissez-vous guider par votre imagination, écoutez votre esprit créateur et amusez-vous à construire des modèles pendant des heures.

Vous trouverez dans cette boîte toutes les pièces et accessoires nécessaires pour créer de super modèles. Ces instructions ne sont qu'un exemple. Ne vous y limitez pas. Inventez d'autres modèles et bâtissez votre univers K'NEX !

N'oubliez pas non plus d'essayer les autres kits K'NEX qui vous proposeront encore plus de thèmes et de modèles pour enfants de tous les âges !

Visitez le site K'NEX au www.knex.com ou appelez-nous au 1-800-KID-KNEX.

¡Enhorabuena! Has descubierto K'NEX, el sistema de construcción galardonado, que te permite construir y hacer que cobre vida todo aquello que puedas imaginarte.

¡Da rienda suelta a tu imaginación! ¡Sácale partido a tu creatividad! Y, de paso, ¡diviértete de lo lindo!

Este juego tiene todo lo que necesitas para crear, con las piezas K'NEX, los modelos más divertidos. Las instrucciones te muestran el camino, pero el juego no tiene límites. ¡Diseña tus propios modelos! ¡Crea tu propio mundo K'NEX!

Y no olvides que hay muchos otros sets K'NEX para niños de todas las edades, con temas y modelos que te encantarán.

Visita el sitio de K'NEX en la Web, www.knex.com, o llámanos al 1-800-KID-KNEX.

Each K'NEX piece has its own color and shape; match it to pieces in the picture instructions. Put pieces together exactly as pictures show. Be sure to put Rods in the correct slots of Connectors, so you have proper angles in your finished model.

Chaque pièce K'NEX a une couleur et une forme bien à elle. Faites correspondre et montez les pièces les unes sur les autres en suivant exactement les instructions illustrées. Assurez-vous de bien assembler les tiges dans les fentes des connecteurs afin d'obtenir des angles corrects une fois le modèle fini.

Assurez-vous de bien assembler les tiges dans les fentes des connecteurs afin d'obtenir des angles corrects une fois le modèle fini. Asegurarse de colocar las varillas en las ranuras de los conectores, de modo que al terminar el modelo, los ángulos sean los adecuados.

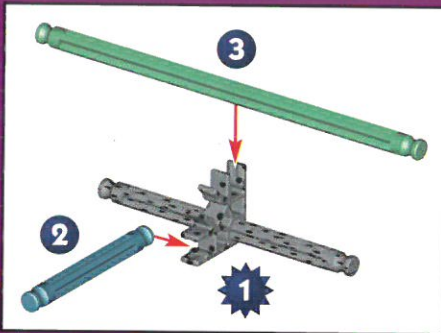

Pay close attention to the number of blue and silver Spacers needed.

Comptez bien le nombre de rondelles bleues et argentées nécessaires.

Prestar atención al número de espaciadores azules y plata que se necesitan.

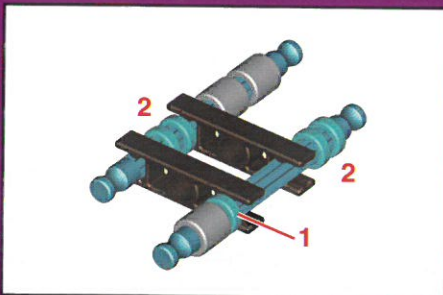

Faded colors indicate sections previously built; connecting points will be in full color.

Les couleurs plus claires indiquent les sections déjà construites. Les points de jonction sont indiqués en couleurs vives.

Los colores apagados indican secciones que ya han sido montadas anteriormente. Los puntos de conexión se indican con colores vivos.

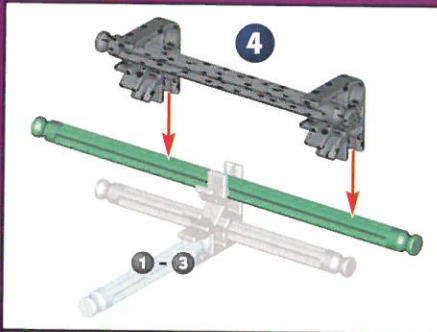

Hinges come in 2 pieces when you first open your set. Just follow the diagrams and snap the two halves together.

Lorsque tu ouvres le jeu pour la première fois, les articulations comportent deux pièces. Il suffit de suivre les schémas et de raccorder les deux moitiés d'un coup sec.

Las bisagras vienen en dos piezas cuando abres el juego. Sigue el diagrama y engancha las dos mitades.

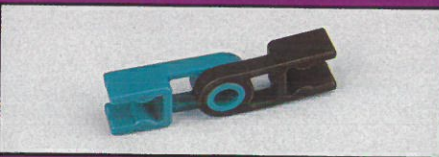
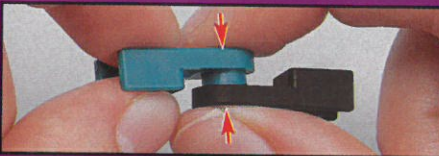

CAUTION: Keep hands, face, hair, clothing away from all moving parts.

ATTENTION: Tenez les mains et les cheveux à l'écart de toute pièce en mouvement.

PRECAUCIÓN: Mantenga las manos y el cabello alejados de todos los componentes móviles.

It's very important to position blue and silver Connectors in a specific direction. Pay close attention to the instructions, and position these Connectors horizontally or vertically exactly as they are shown. Push together tightly until you hear a "click".

Il est important de bien placer les connecteurs bleus et argentés dans le bon sens. Lisez attentivement les instructions et placez ces connecteurs horizontalement ou verticalement selon l'indication. Appuyez dessus en forçant légèrement jusqu'à ce que vous entendiez un dé clic.

Es muy importante colocar los conectores de color azul y plata en una dirección específica. Prestar mucha atención a las instrucciones y colocar estos conectores según se indica, ya sea horizontal o verticalmente. Para conectarlos, presionar hasta oír un "clíc".

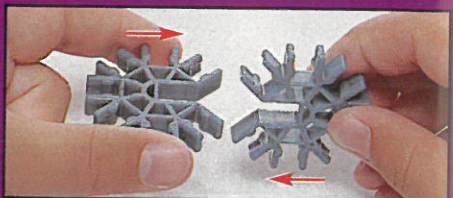
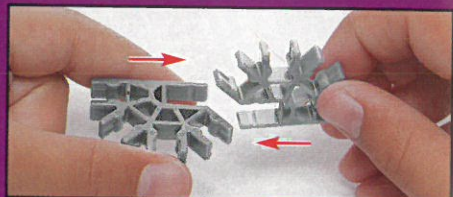
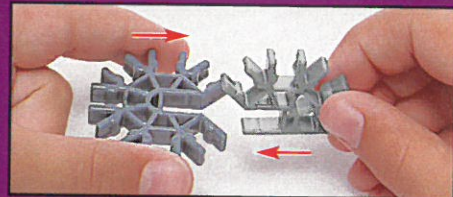

⚠ CAUTION: Rubber Bands can cause injury from snap-back, breaking, or loss of control. While assembling models shown in instructions, hold Rubber Band tightly, and do not overstretch. Use Rubber Bands only as shown in these instructions. **DO NOT USE FRAYED OR TORN RUBBER BANDS.**

⚠ ATTENTION: les élastiques peuvent causer des blessures en claquant, en se cassant ou quand on les manipule imprudemment. Tenez fermement l'élastique lors de l'assemblage du modèle en veillant à ne pas trop le tendre. N'utilisez les élastiques que selon les instructions. **N'UTILISEZ PAS D'ÉLASTIQUES ÉRAILLÉS OU DÉCHIRÉS.**

⚠ PRECAUCIÓN: las gomas pueden causar daños si se sueltan con fuerza, se rompen o se pierde su control. Al construir los modelos que se muestran en las instrucciones, sujetar bien la goma y no estirarla demasiado. Las gomas deben usarse únicamente como se indica en las instrucciones. **NO USAR GOMAS QUE ESTÉN DESGASTADAS NI RASGADAS.**

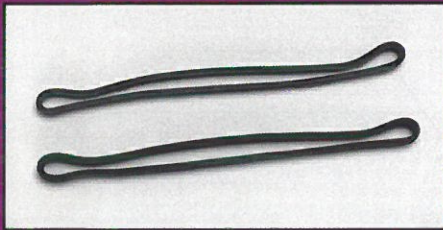



Push together tightly until you hear a "click".

Poussez fermement jusqu'à ce que vous entendiez un déclic.

Júntalos, empujando uno con otro, hasta que oigas un chasquido o "clic".



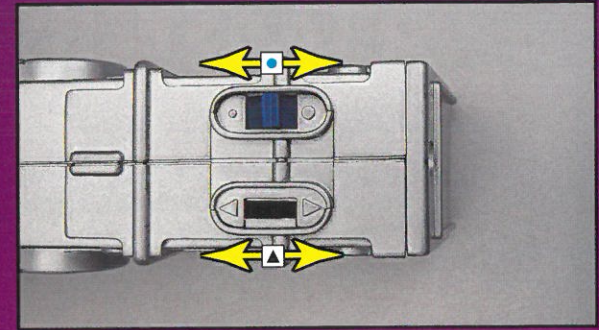

Install the batteries before you build.

- Remove rechargeable batteries from model before charging; they must be charged only under adult supervision.
- Non-rechargeable batteries must not be recharged.
- Do not mix different types of batteries; do not mix alkaline, standard (carbon-zinc), or rechargeable (nickel-cadmium) batteries. Do not mix new and used batteries. Only batteries of the same or equivalent type recommended should be used.
- Insert batteries with correct polarity (+/-) as shown.
- Remove exhausted batteries from model; do not short-circuit supply terminals.
- Keep motor free of dust; do not immerse or use in water.
- 4 alkaline batteries AA (LR6) are recommended.
- **Do not put small black Rods in any openings of the motor; they will damage the motor, and cannot be removed.**
-  High and low speed control switch
-  Forward and reverse switch



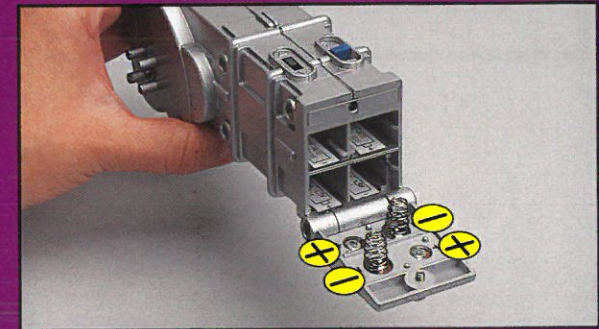

Installer les piles avant l'assemblage.

- Enlevez les piles rechargeables du jouet avant de les charger. Elles ne doivent être chargées que sous la supervision d'un adulte.
- Les piles non rechargeables ne doivent pas être rechargées.
- Ne mélangez pas différents types de piles – alcalines, standard (zinc-carbone) ou rechargeables (nickel-cadmium) – ni des piles neuves avec des piles usées. Il est recommandé de n'utiliser que des piles du même type et de type équivalent.
- Insérez les piles en respectant la polarité (+/-), comme illustré.
- Enlevez les piles usées du jouet en prenant soin de ne pas court-circuiter leurs bornes.
- Conservez le moteur à l'abri de la poussière. Ne l'immergez pas et ne l'utilisez pas dans l'eau.
- Il est recommandé d'utiliser 4 piles alcalines AA (LR6).
- **Ne mettez pas les petites tiges noire dans les trous du moteur. Elles l'endommageraient et resteraient coincées.**
-  Bouton de réglage de la vitesse (haute/basse)
-  Bouton marche avant/arrière



Instala las pilas antes de construir.

- Extraer del modelo las pilas recargables antes de cargarlas; deben cargarse únicamente bajo la supervisión de una persona mayor.
- Las pilas no recargables no deben cargarse.
- No mezclar distintos tipos de pilas: alcalinas, estándar (carbono-zinc) o recargables (níquel-cadmio). No mezclar pilas gastadas y nuevas. Sólo se debe usar las pilas recomendadas o de un tipo equivalente.
- Introducir las pilas con los polos en posición correcta, según lo indicado (+/-).
- Extraer del modelo las pilas gastadas: no cortocircuitar los bornes de alimentación.
- Mantener el motor libre de polvo. Abstenerse de sumergirlo o usarlo en agua.
- Se recomienda el uso de 4 pilas alcalinas AA (LR6).
- **No meter las varillas negro pequeñas en ninguno de los orificios del motor, ya que dañarían el motor y no podrían sacarse.**
-  Interruptor de control de velocidad alta y baj
-  Interruptor de marcha adelante y marcha atrás

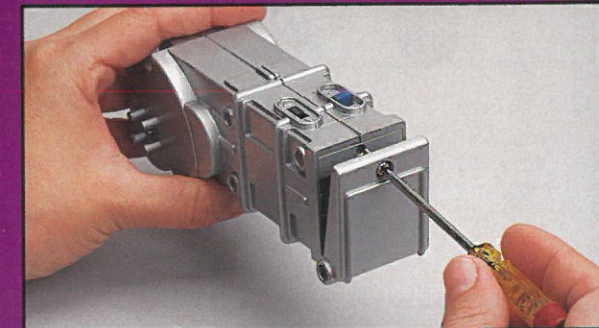
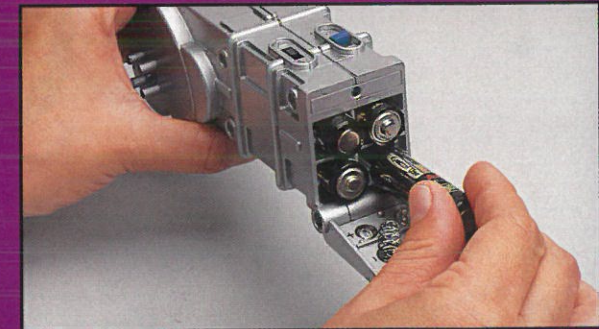

DRAGSTER

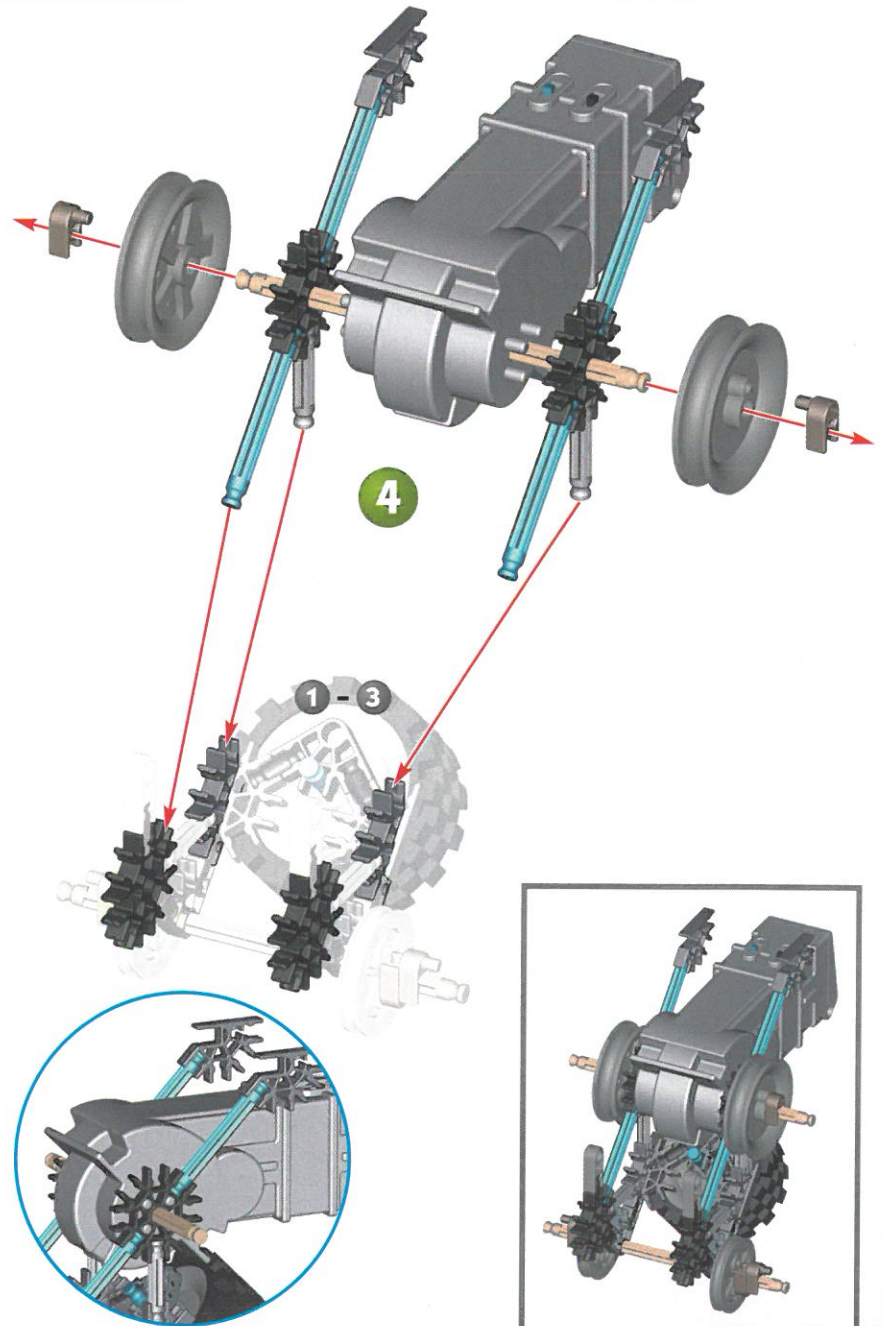
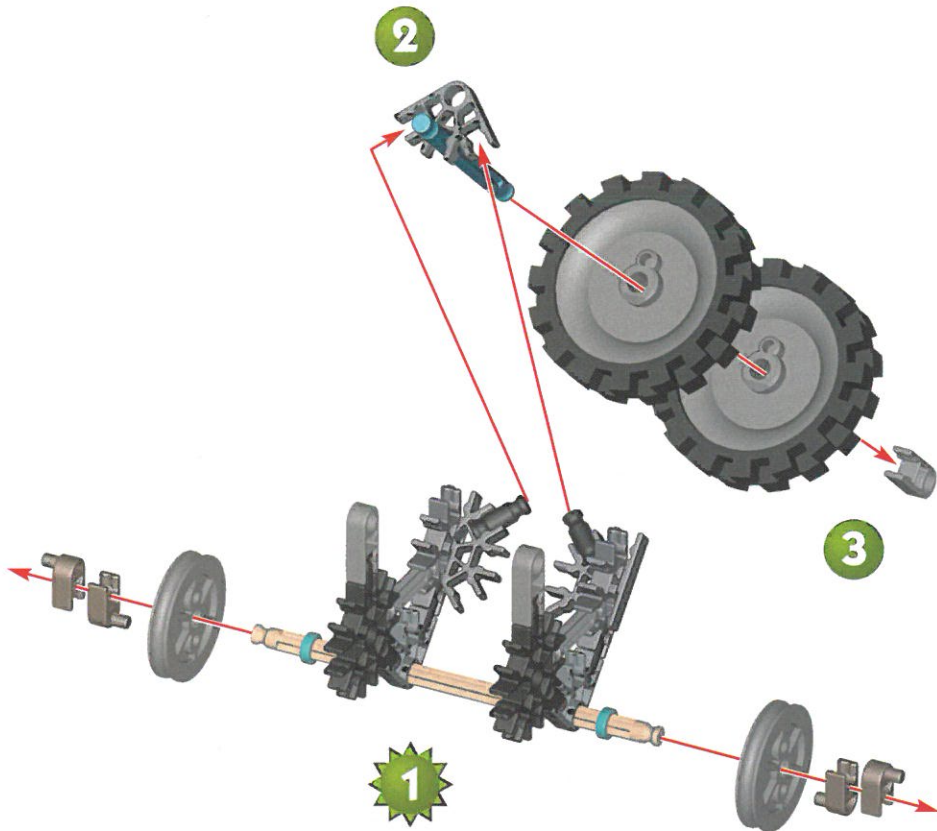

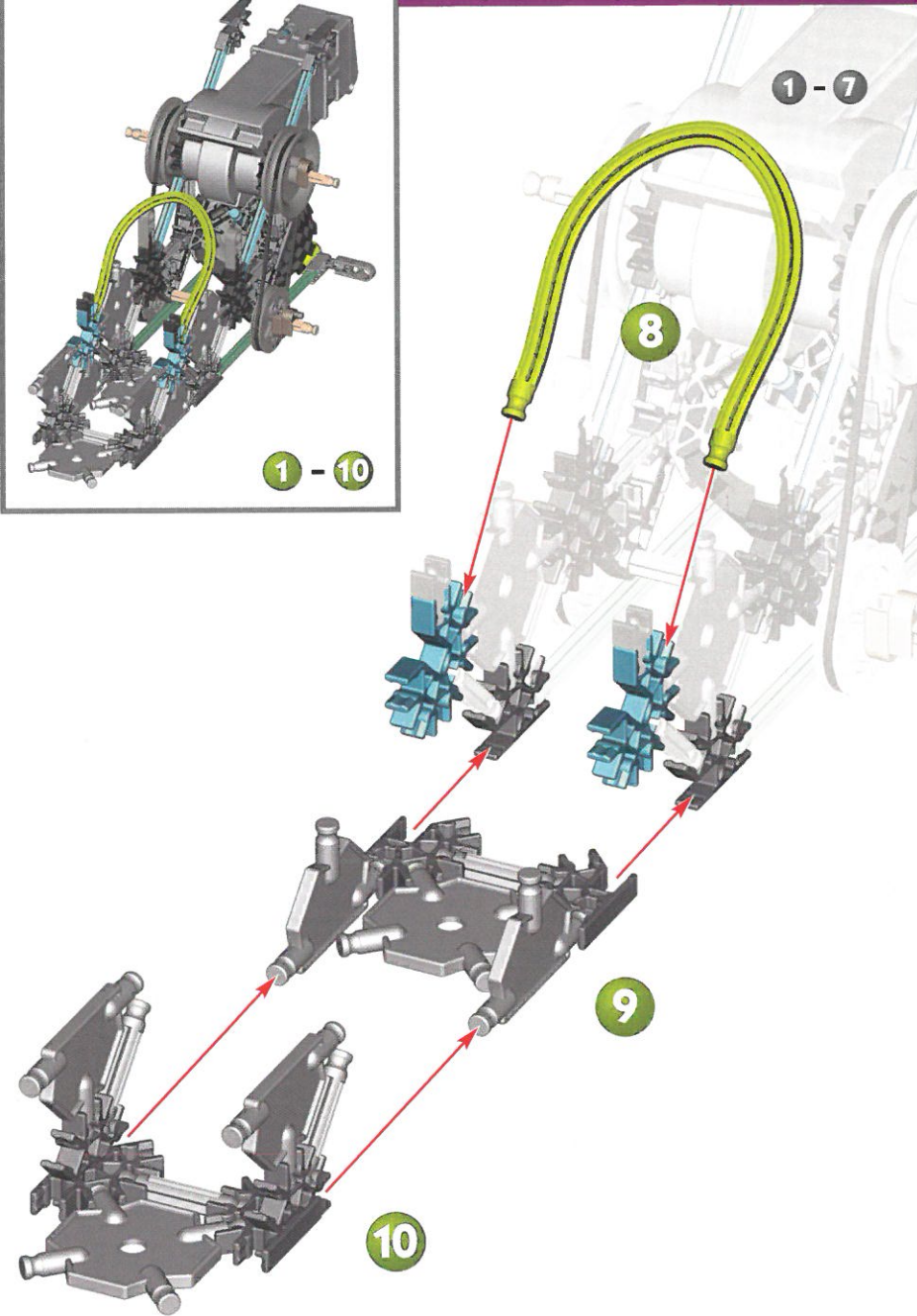
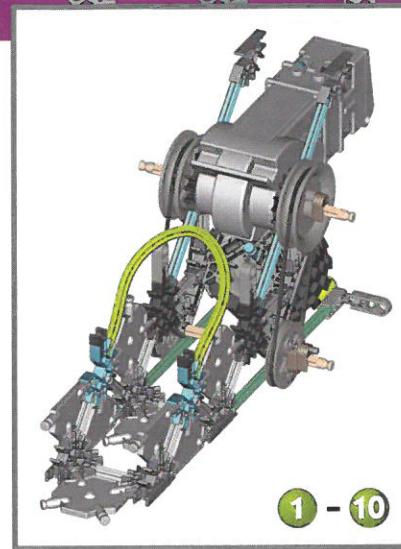
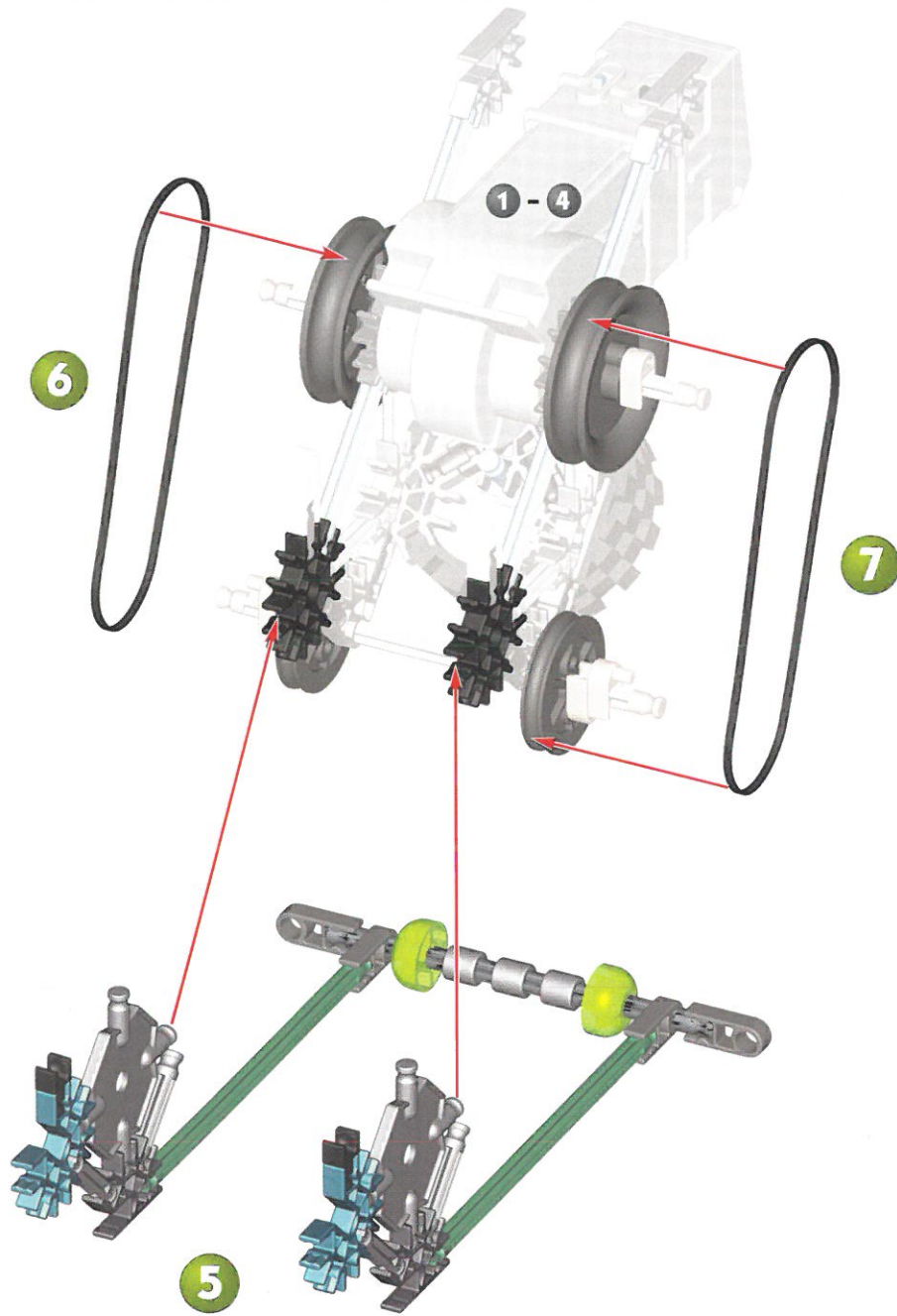

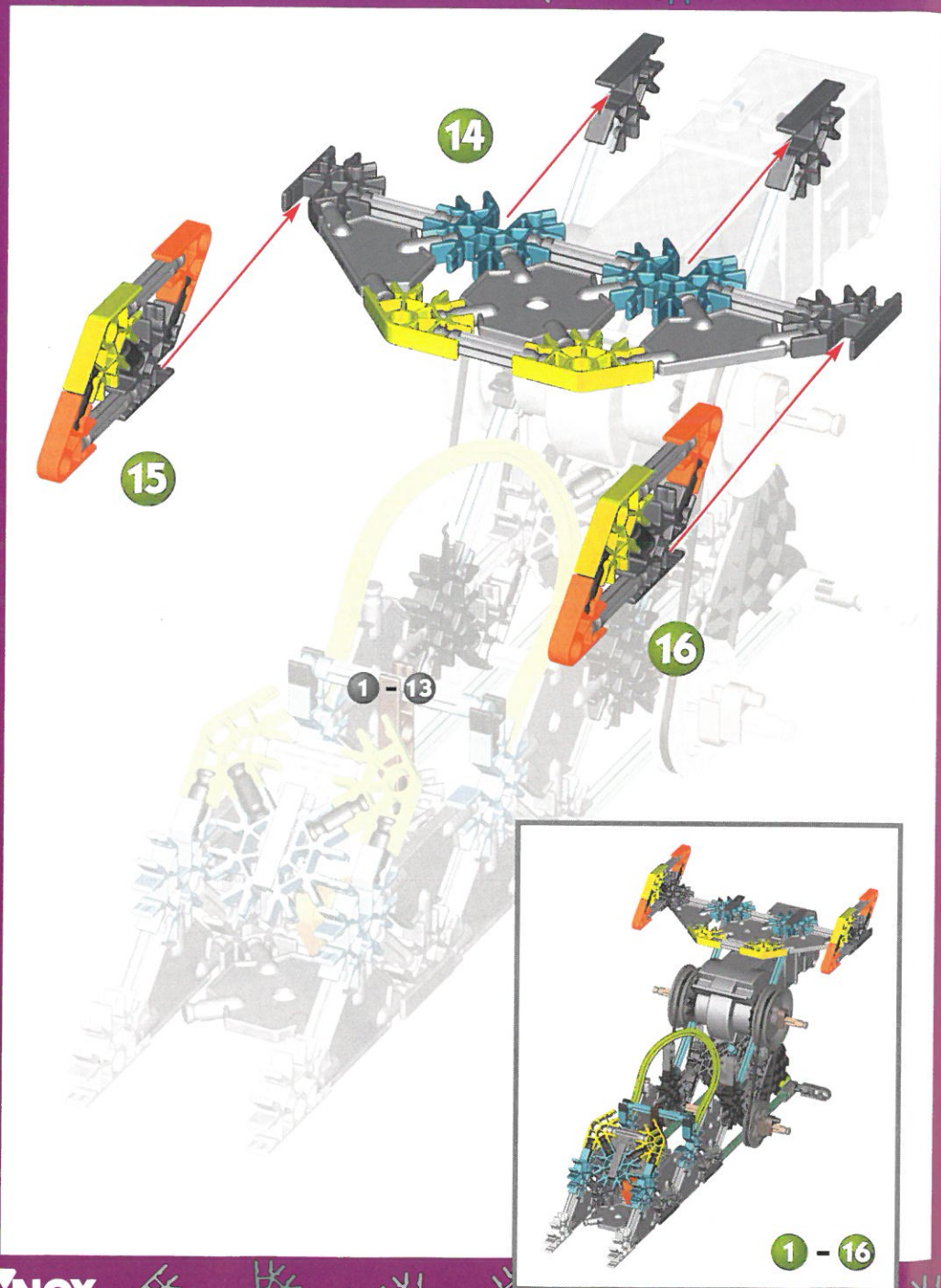
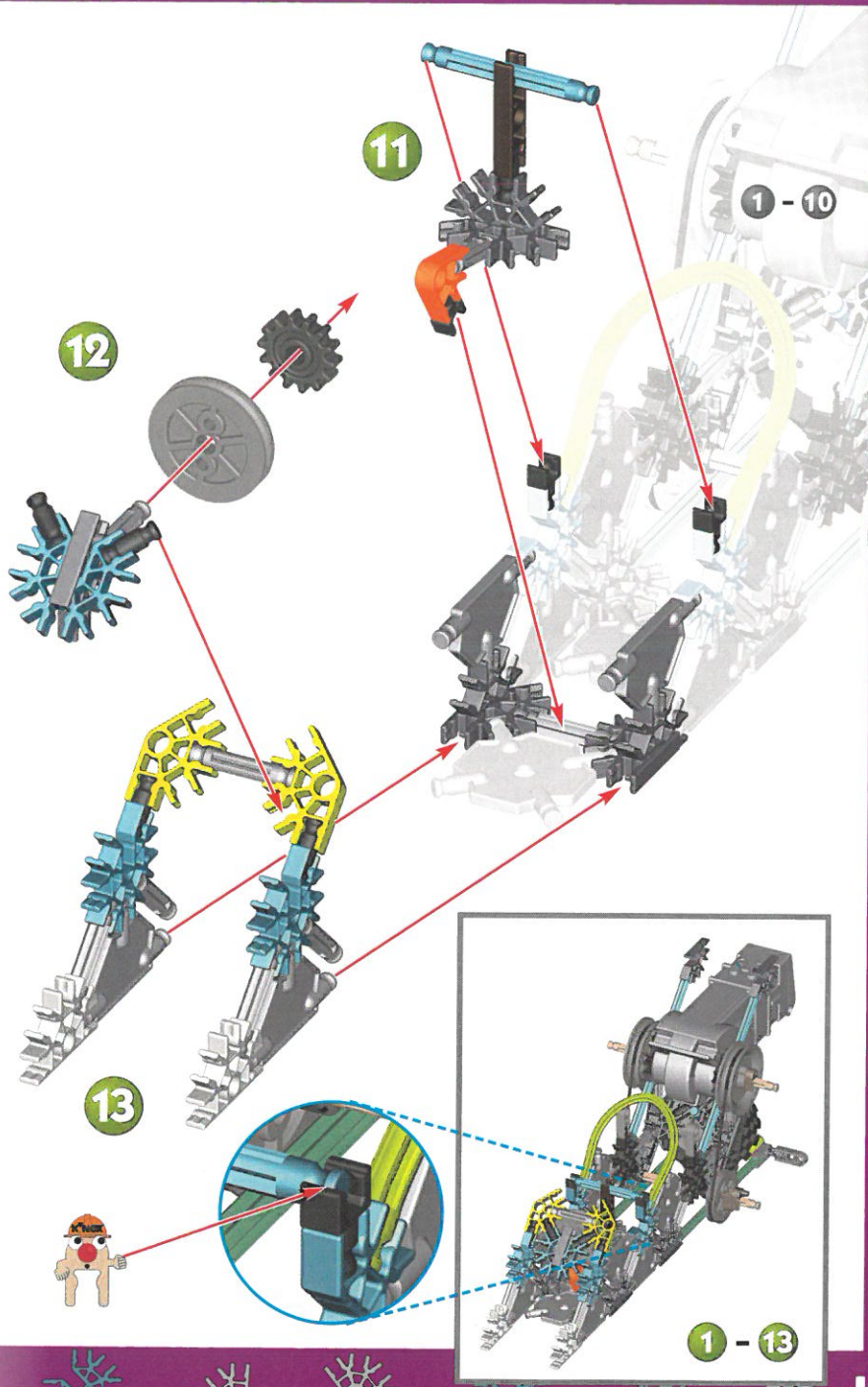

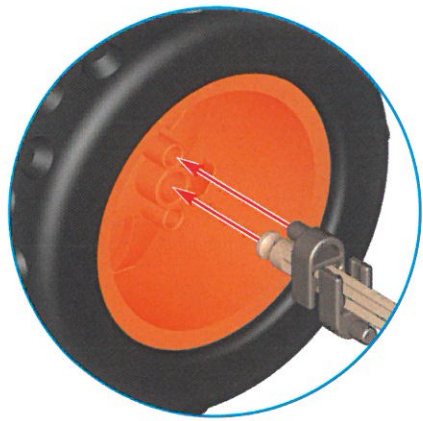

20



1 - 16



19

17

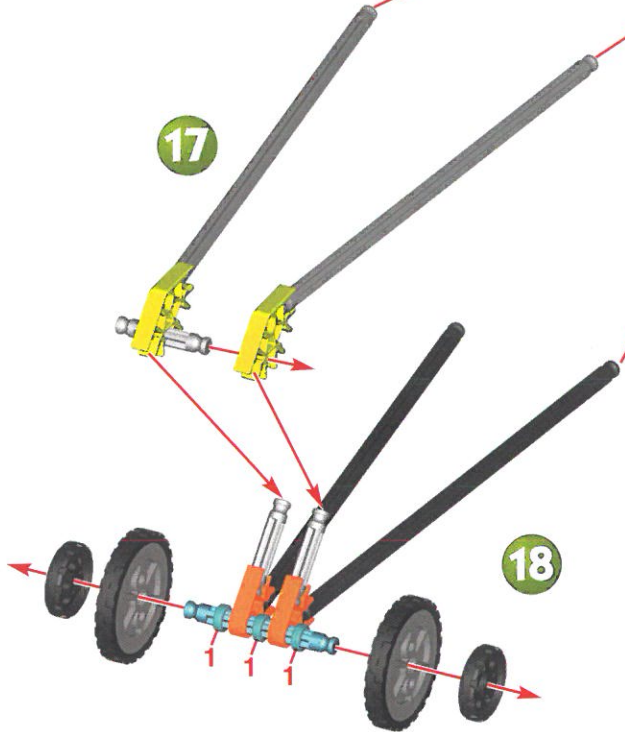

18

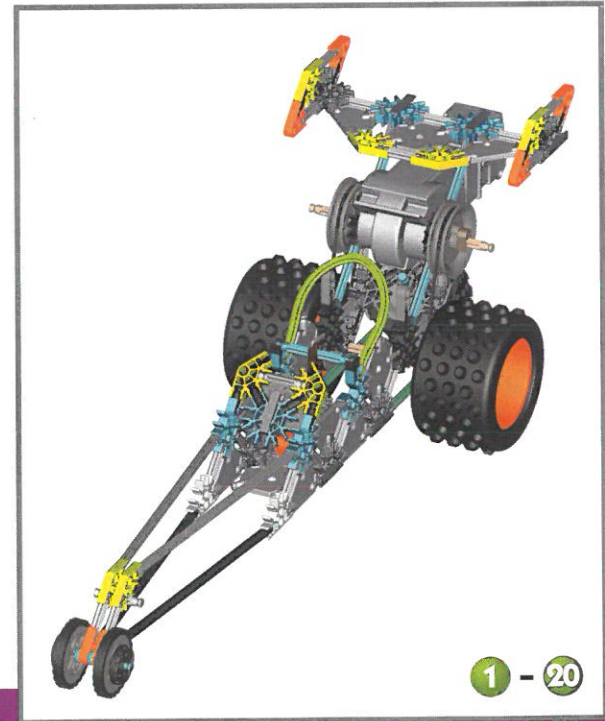

1 - 20

COPTER

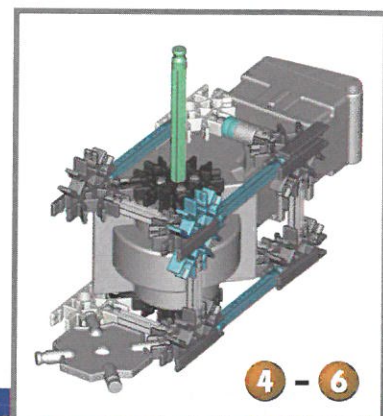
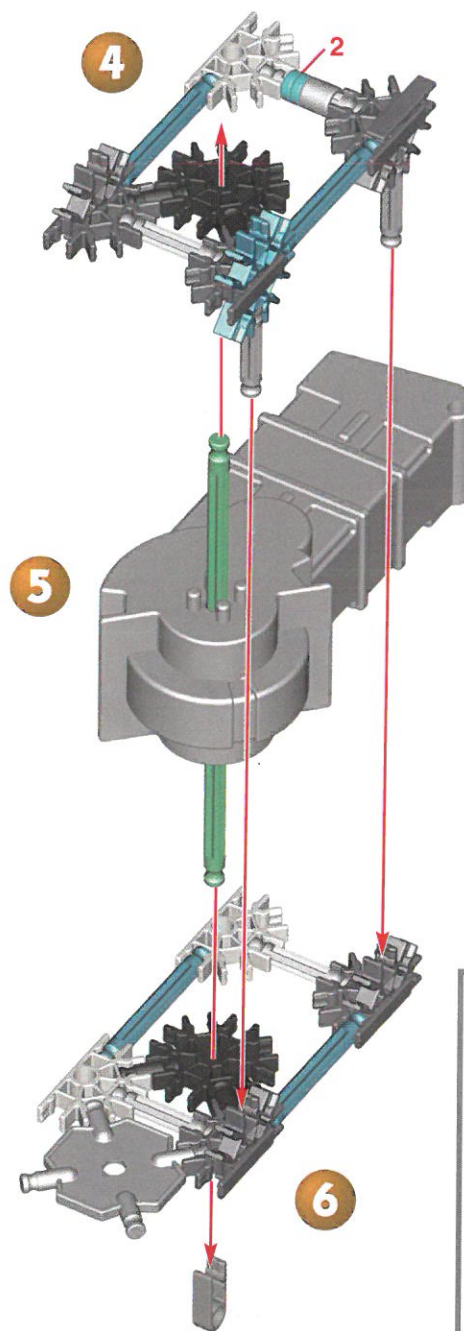
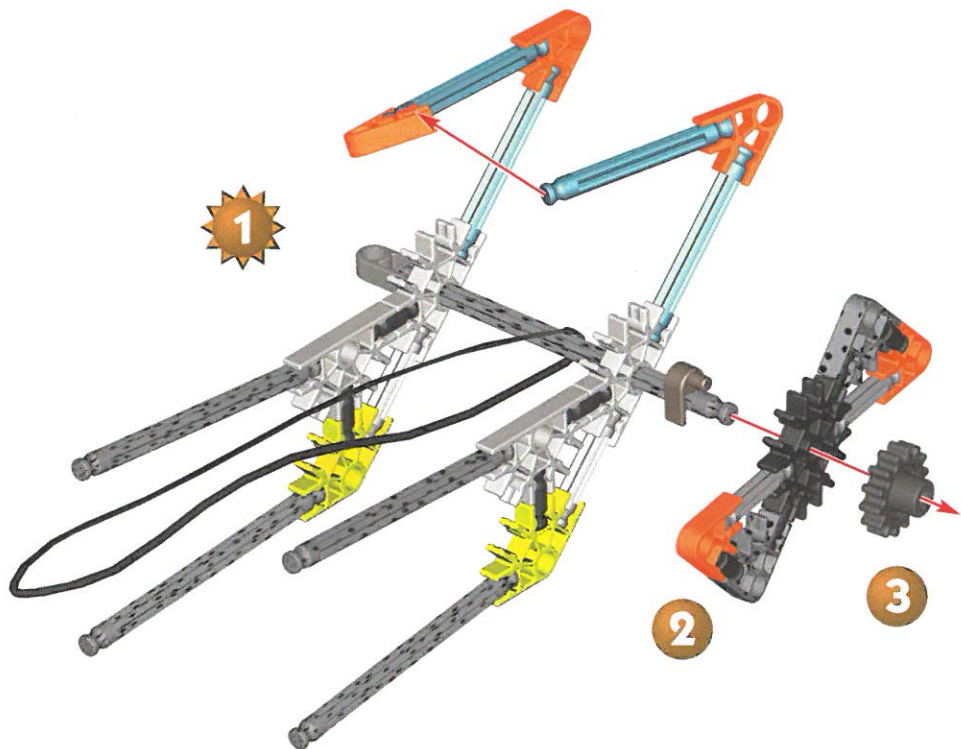
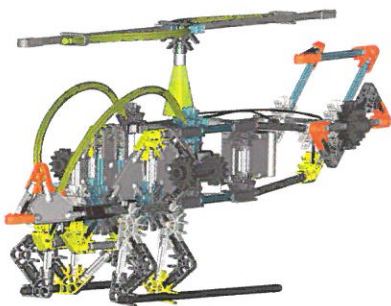

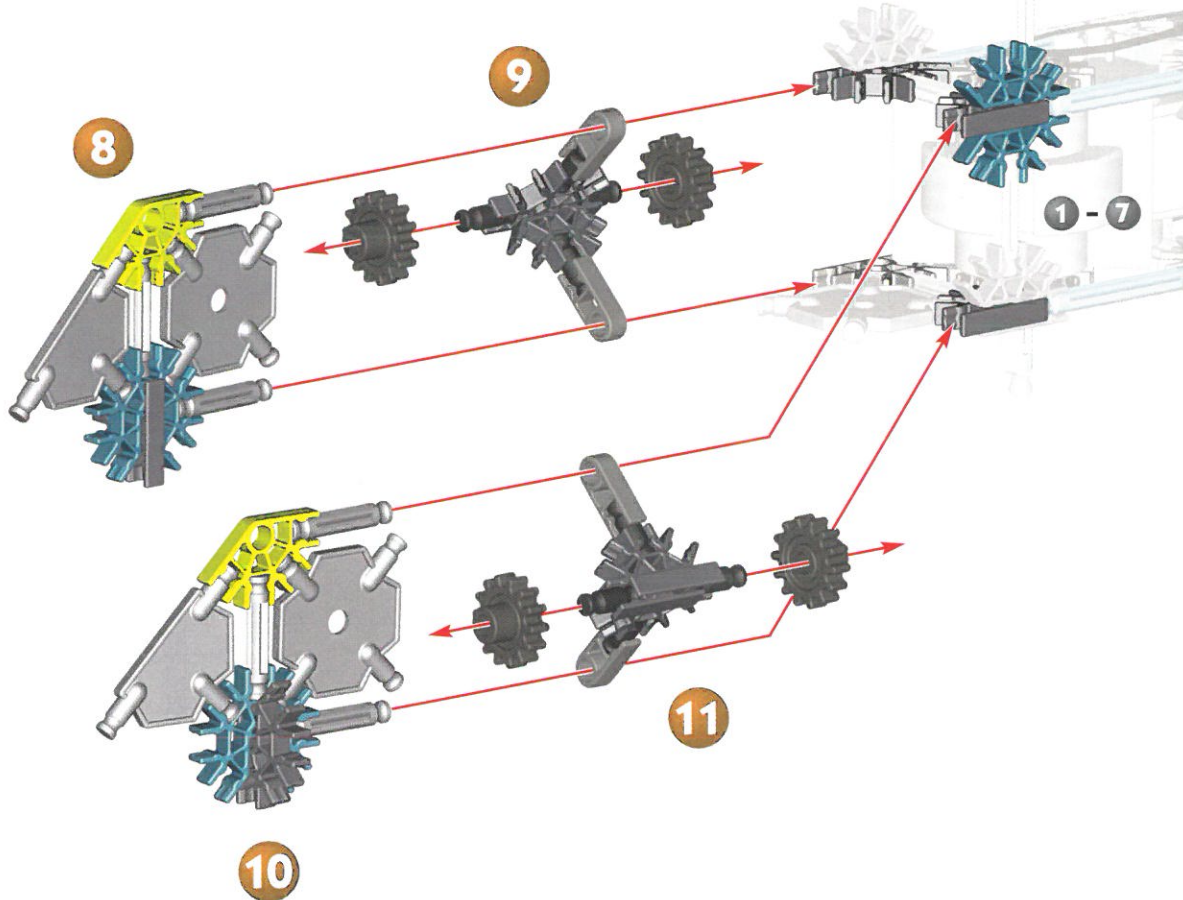
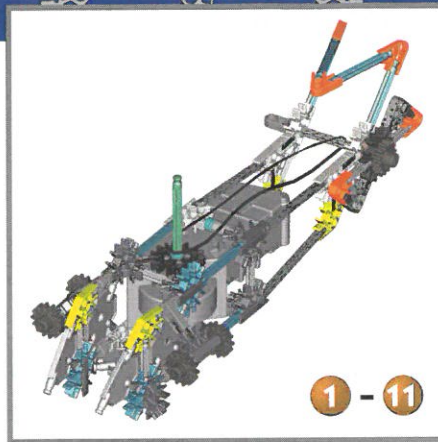
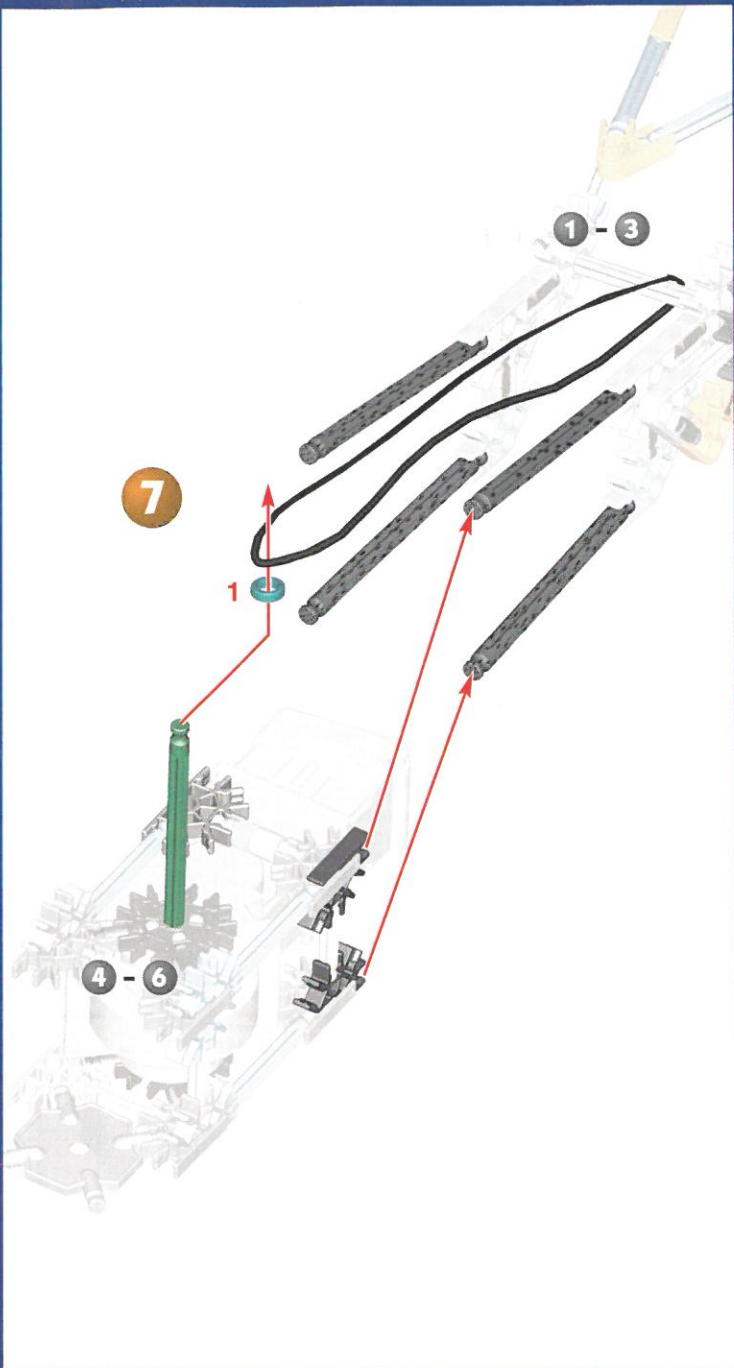

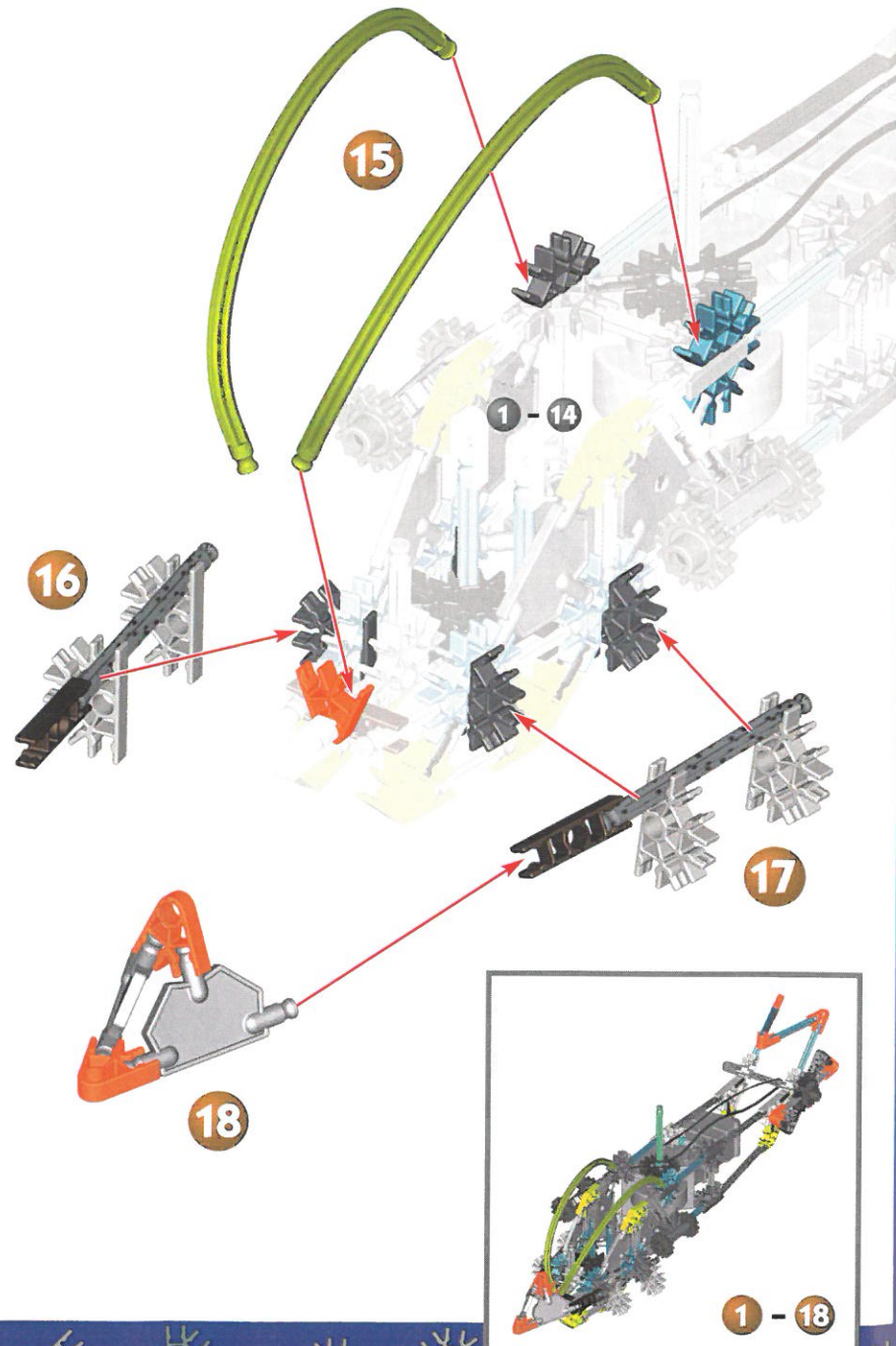
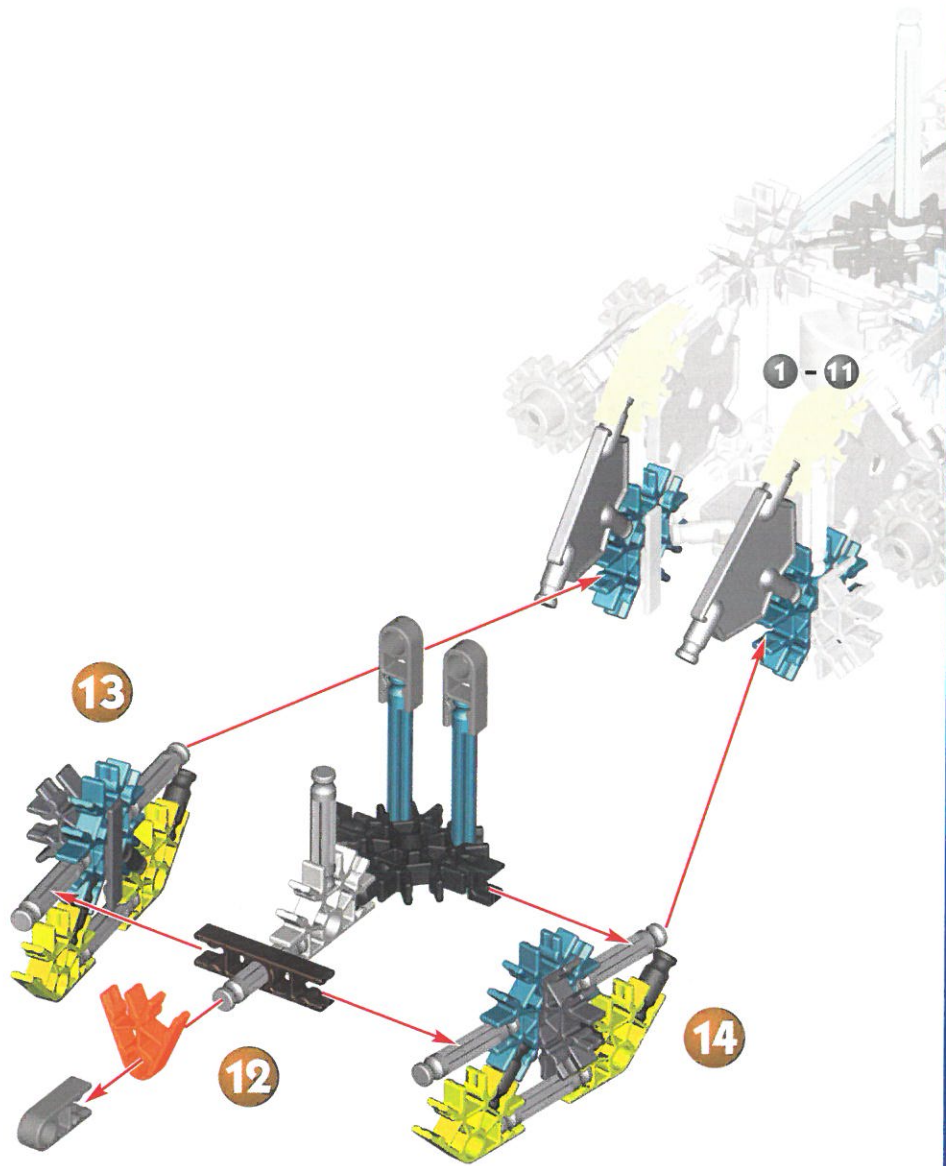
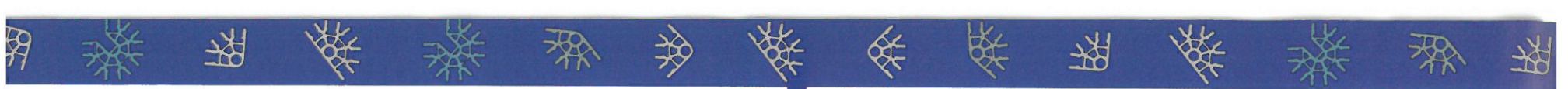

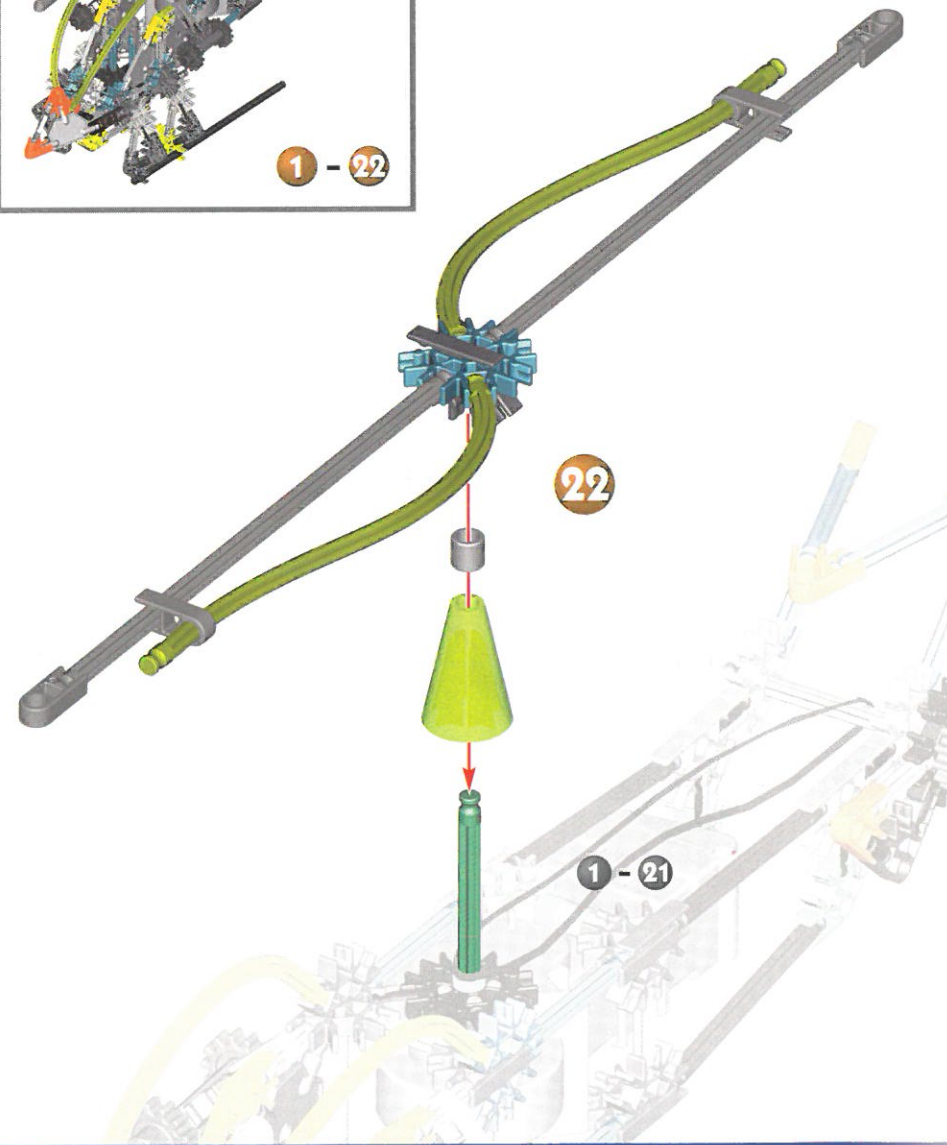
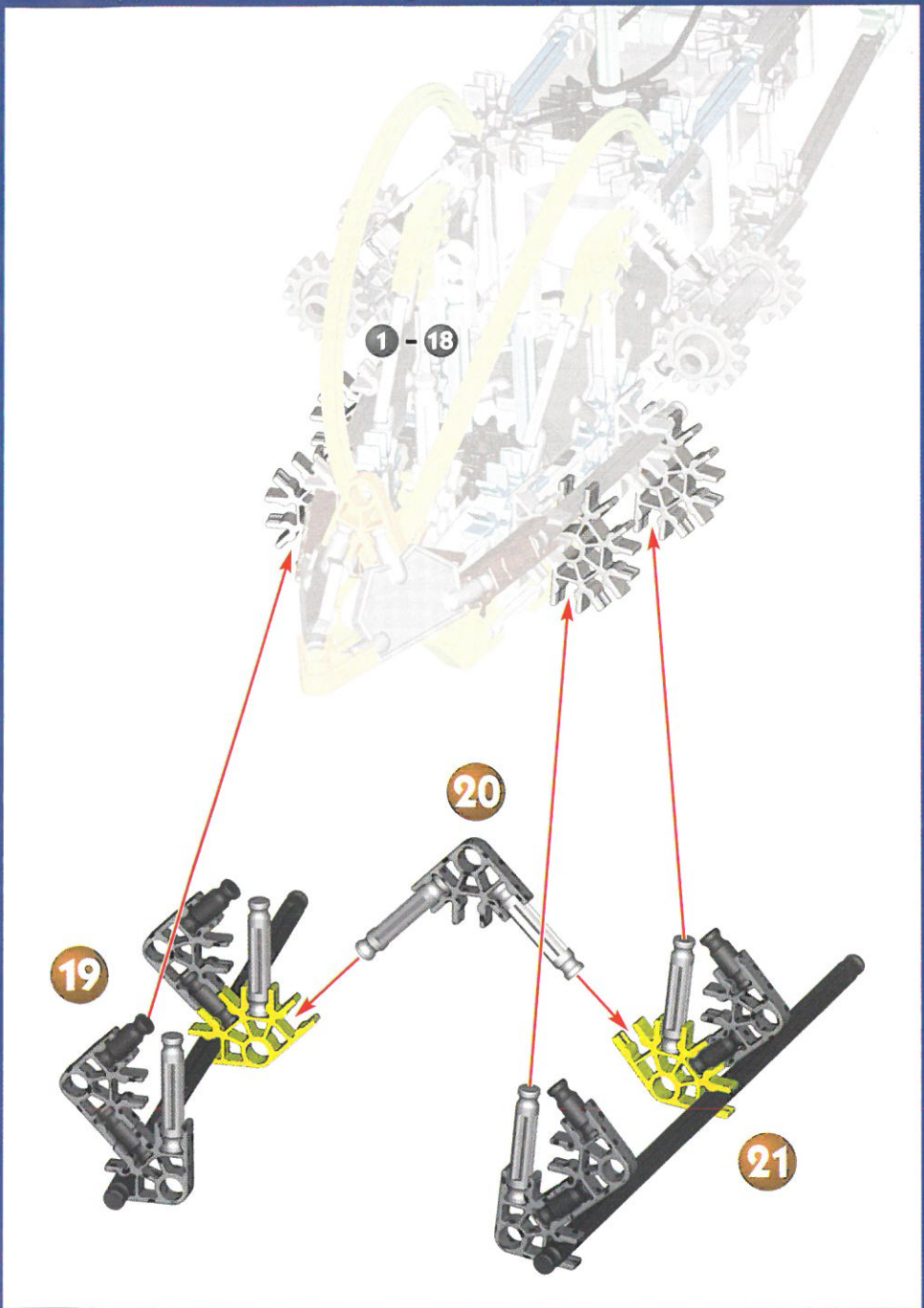

SNOWMOBILE

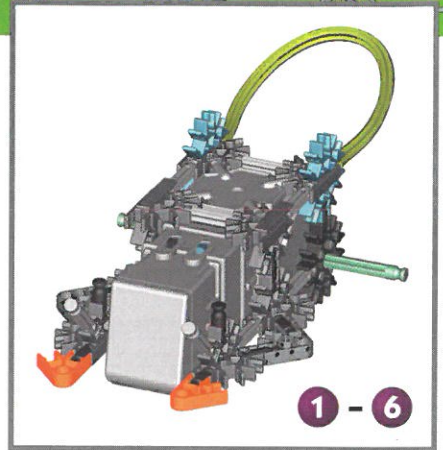
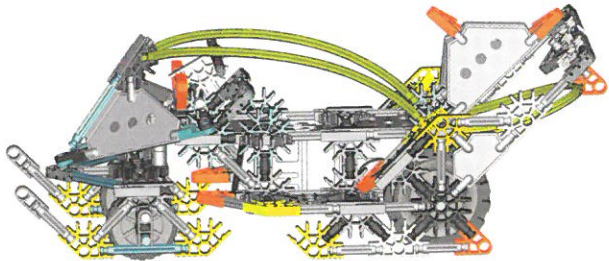

1 - 6

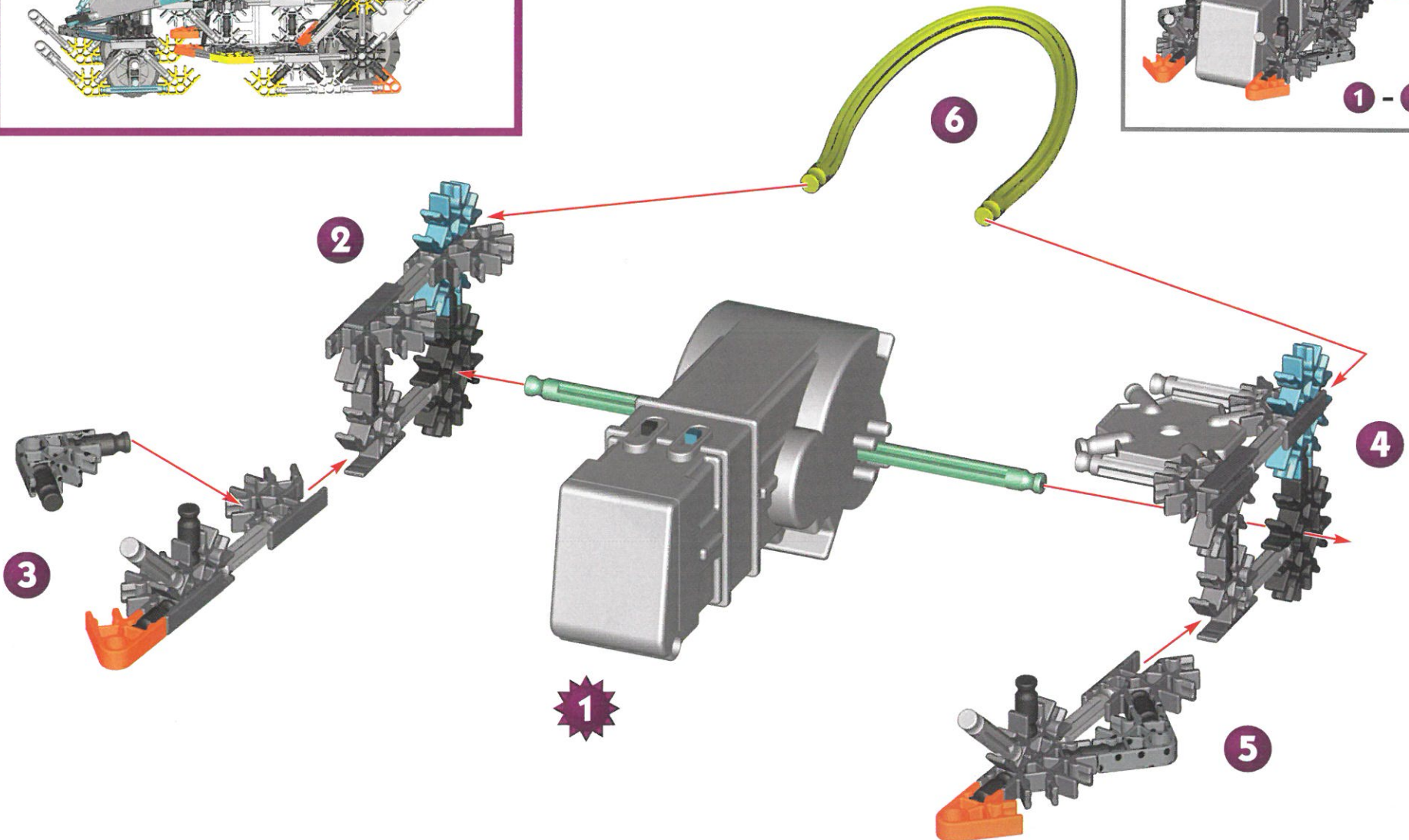

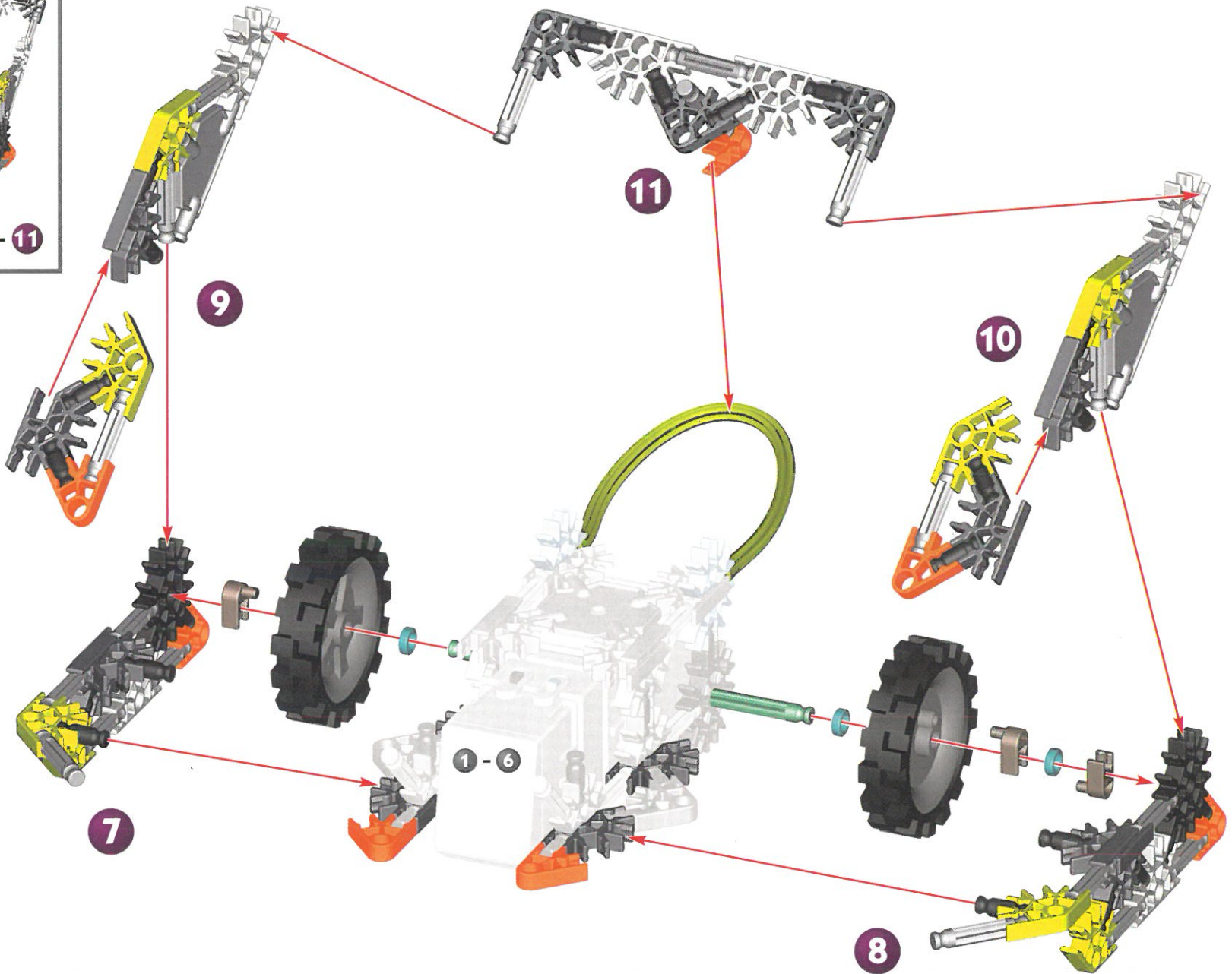
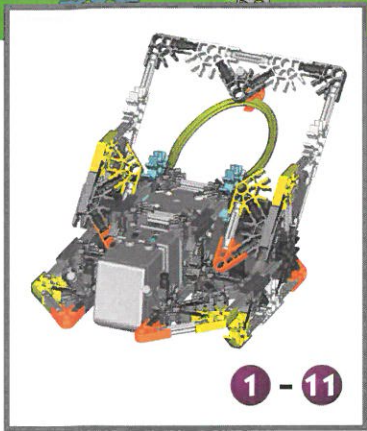



13

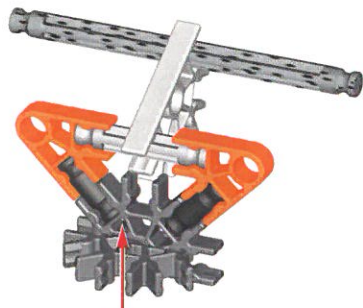

12

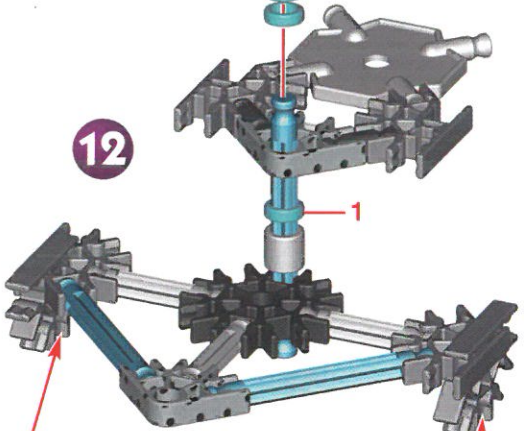

14

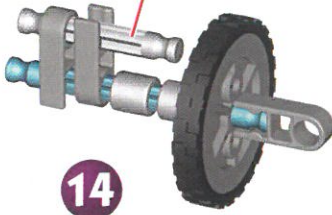

15

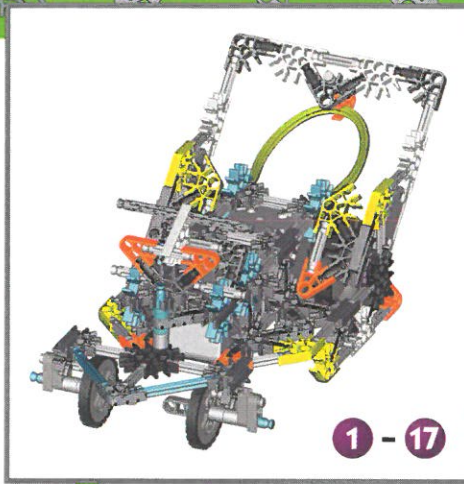
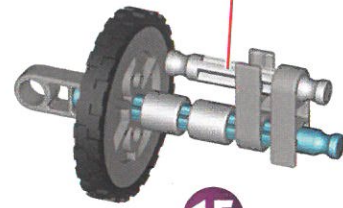

16

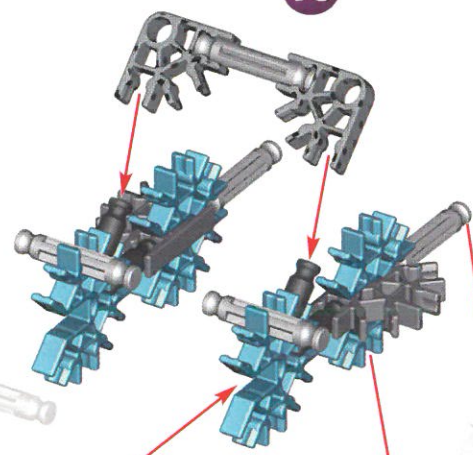

17

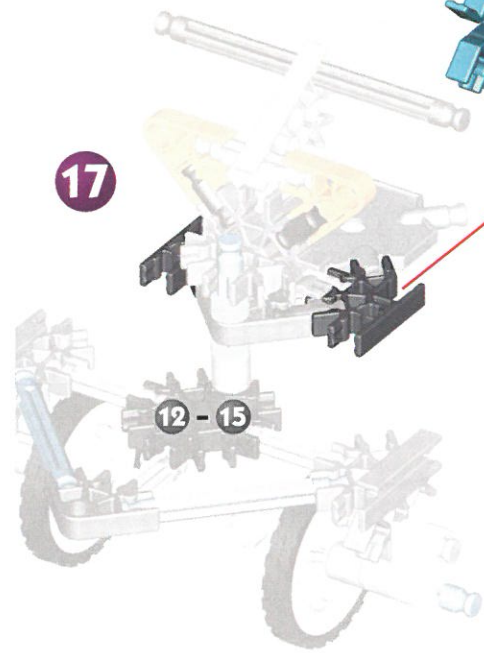

1 - 11

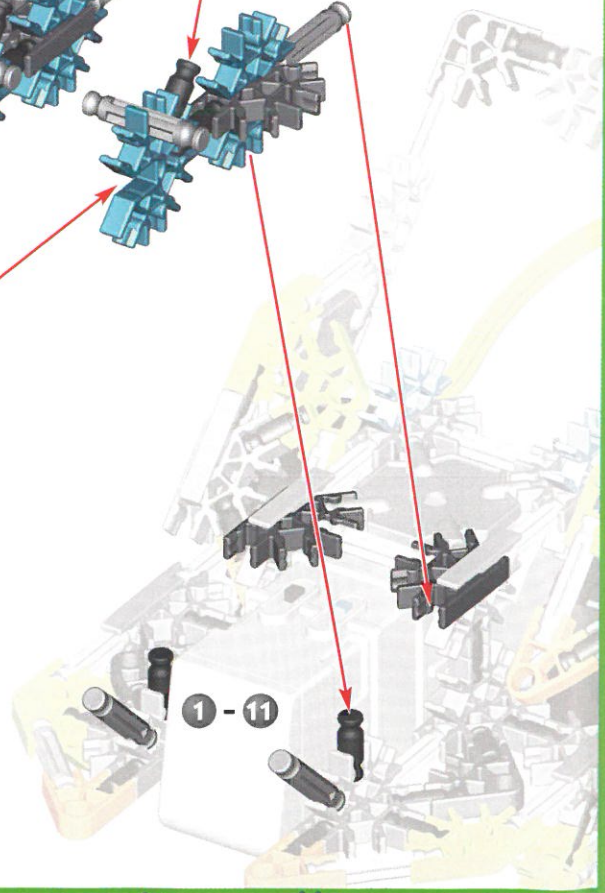

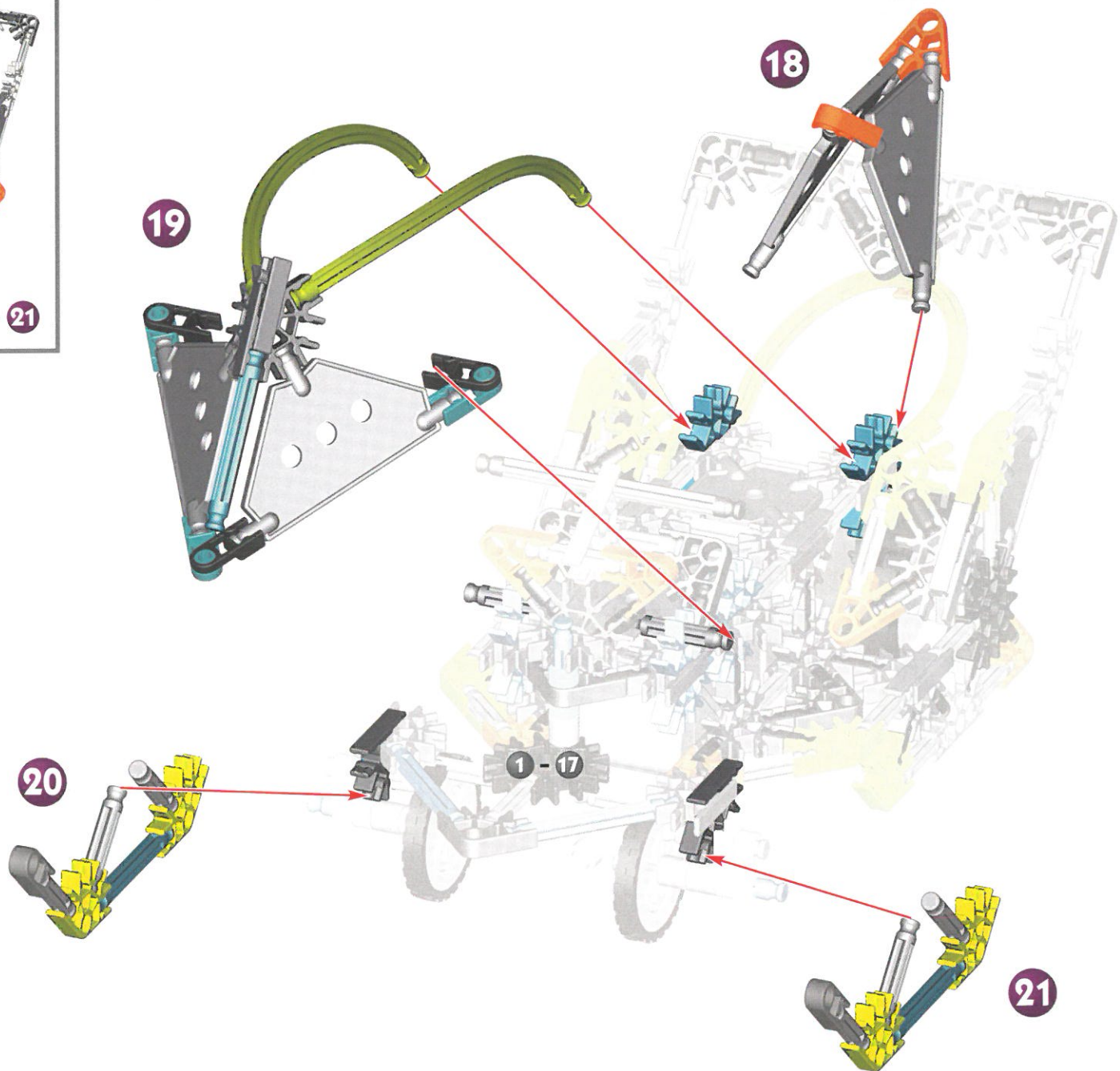
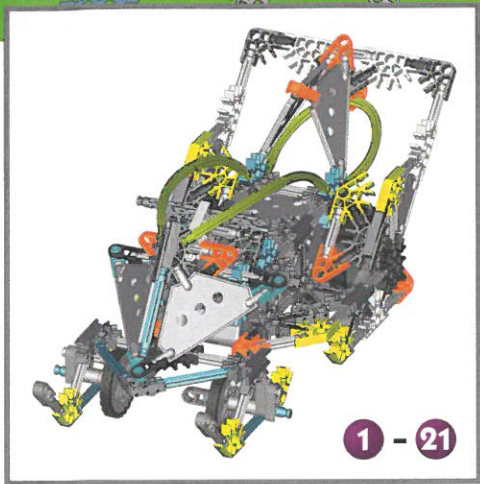

TRIKE

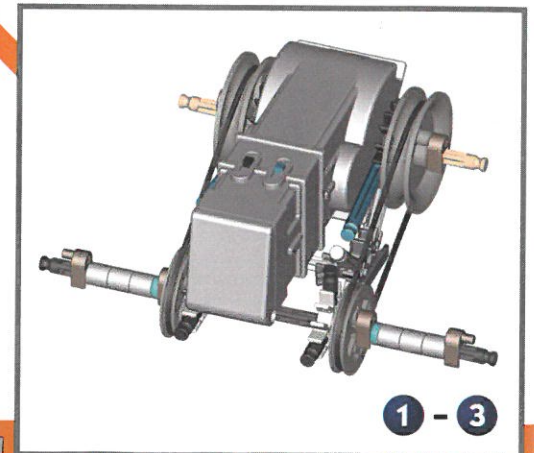
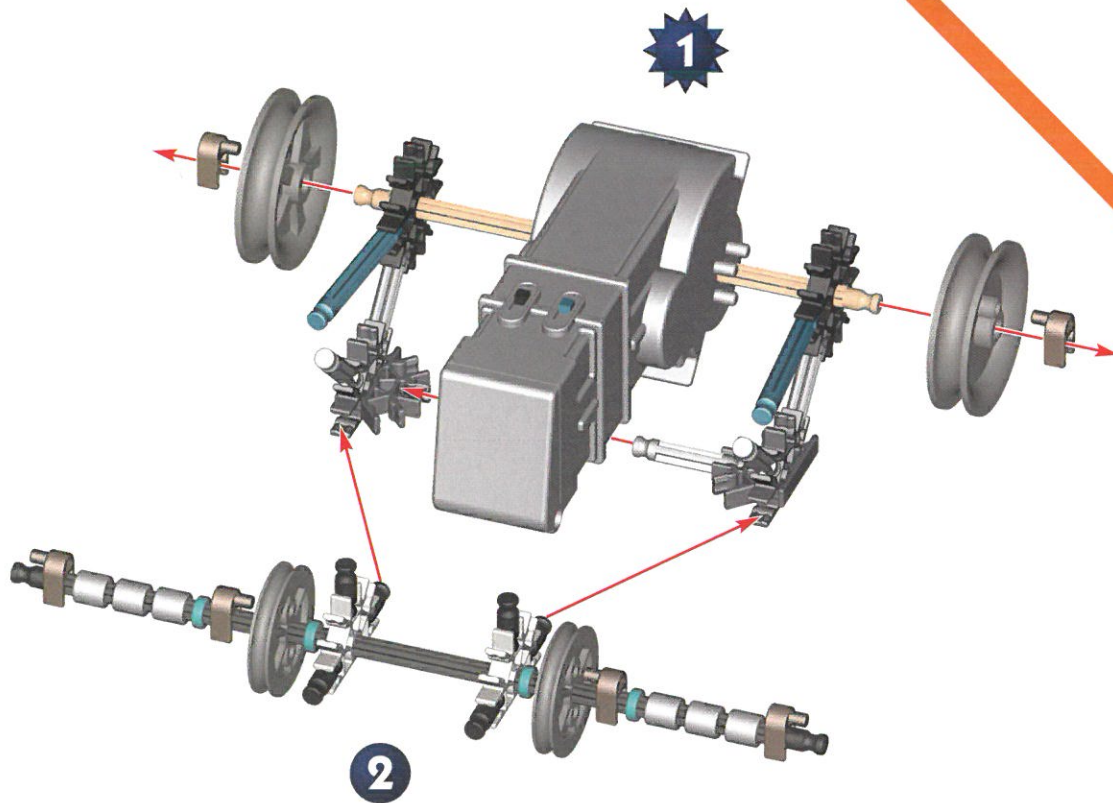
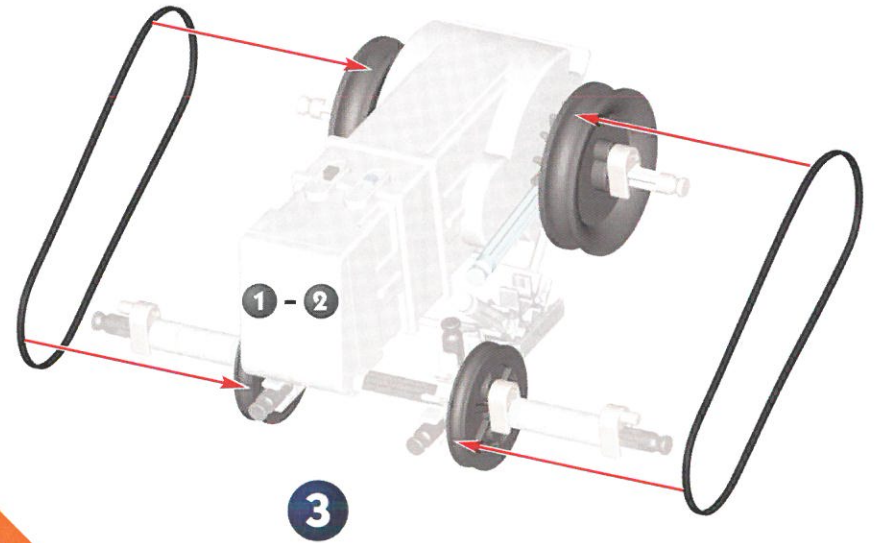

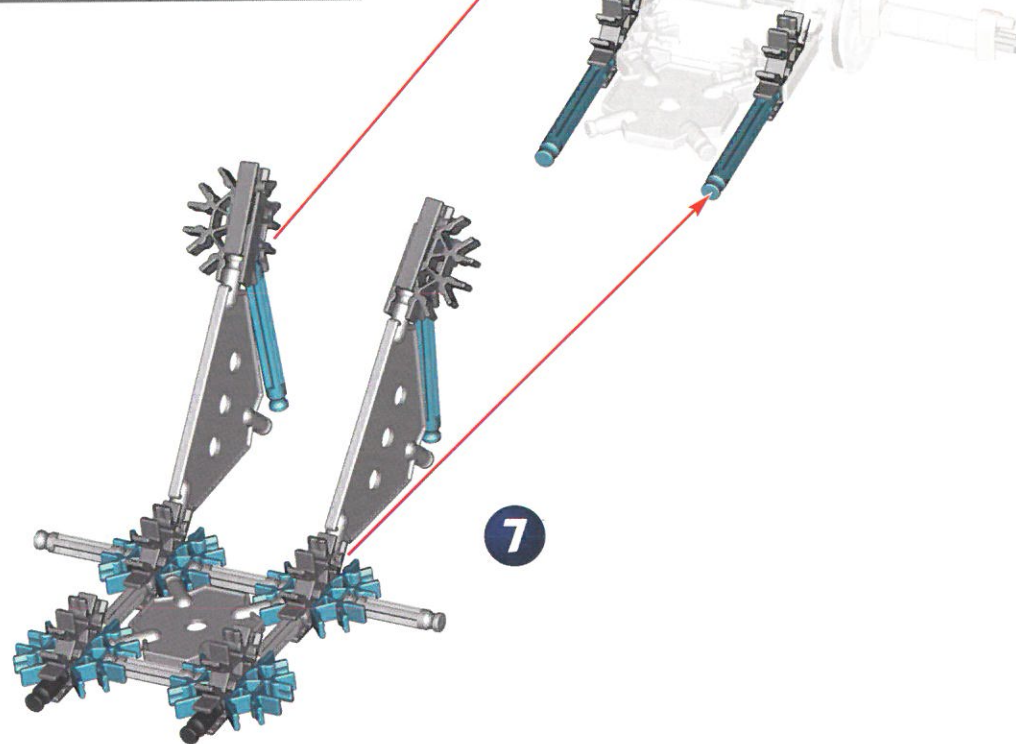
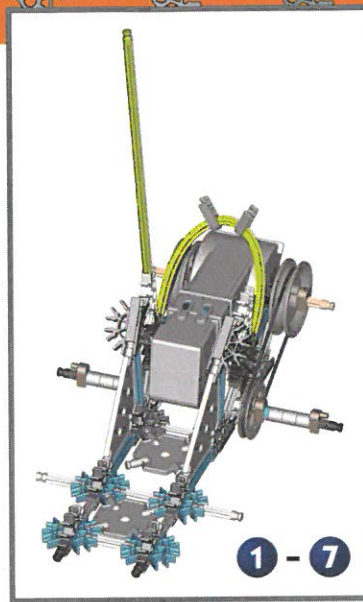
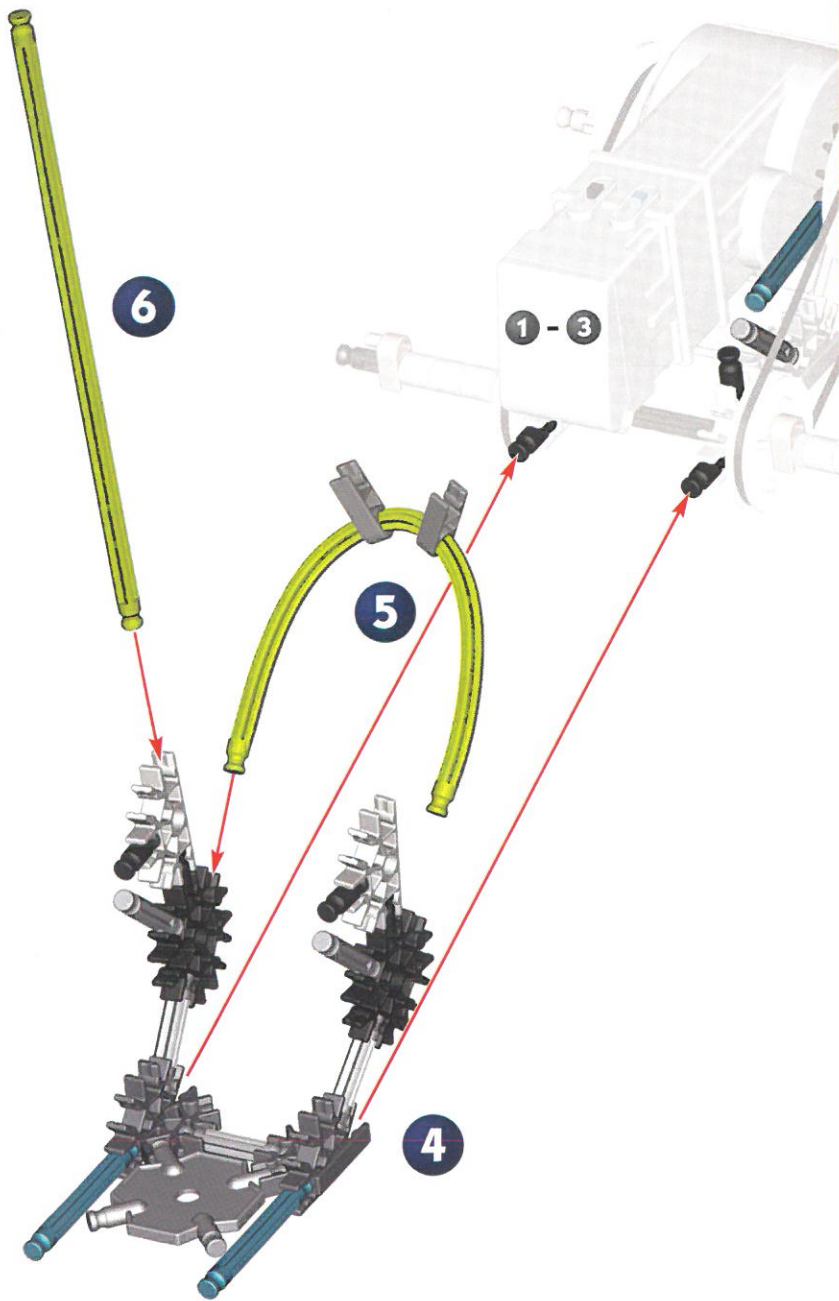

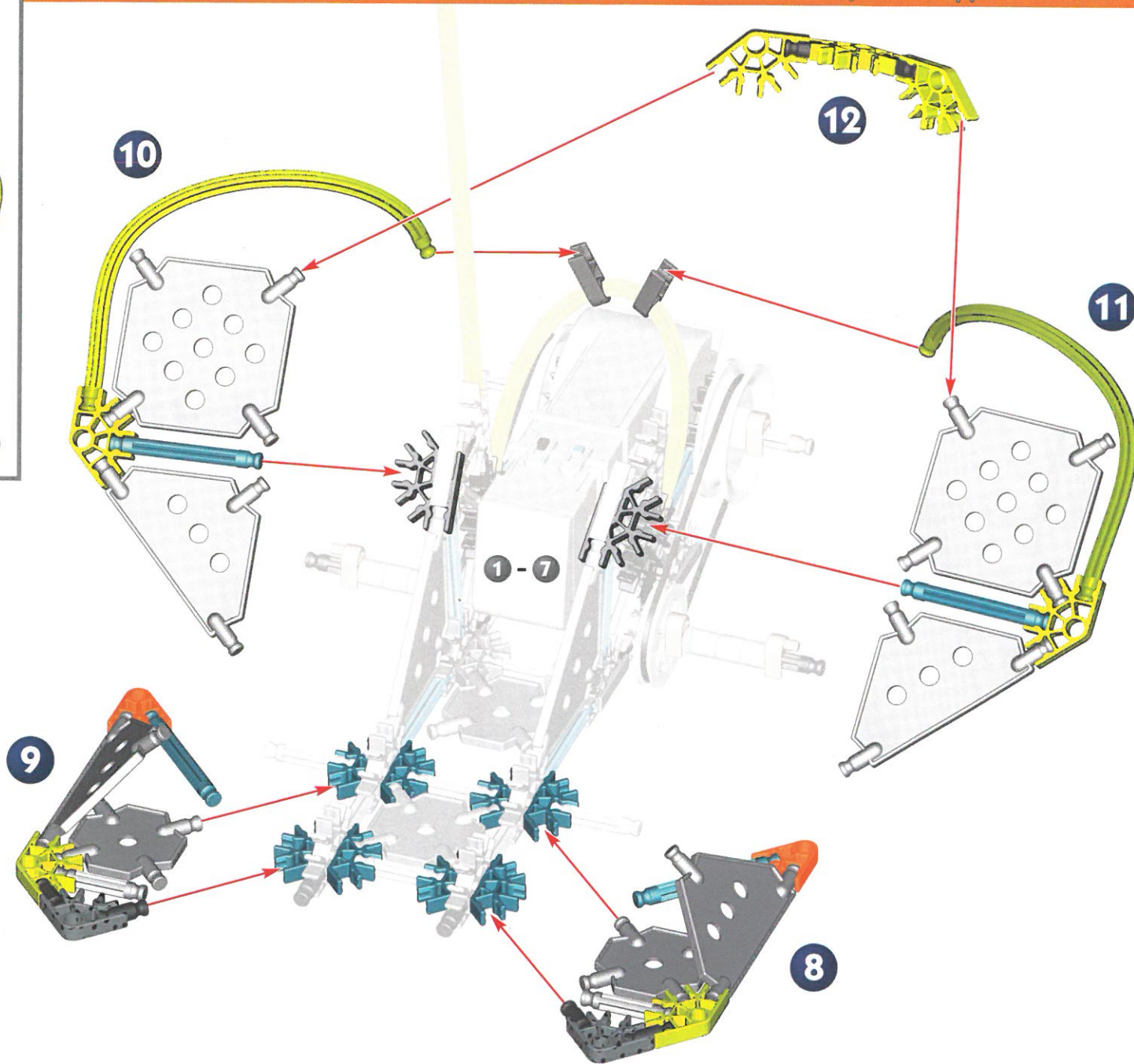
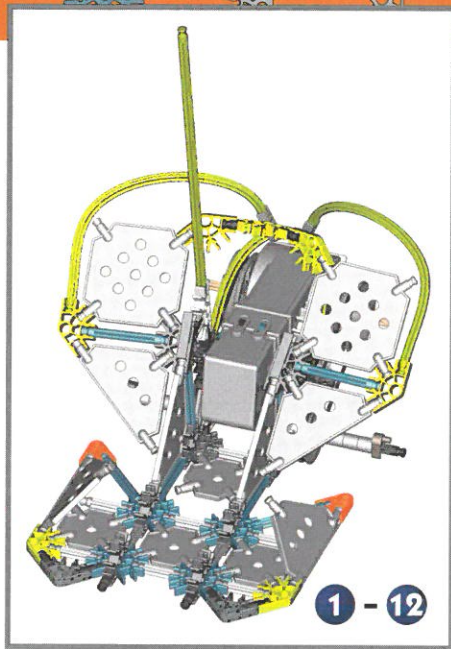

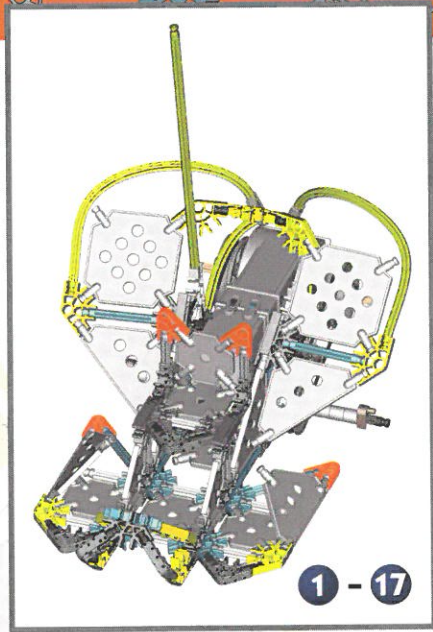
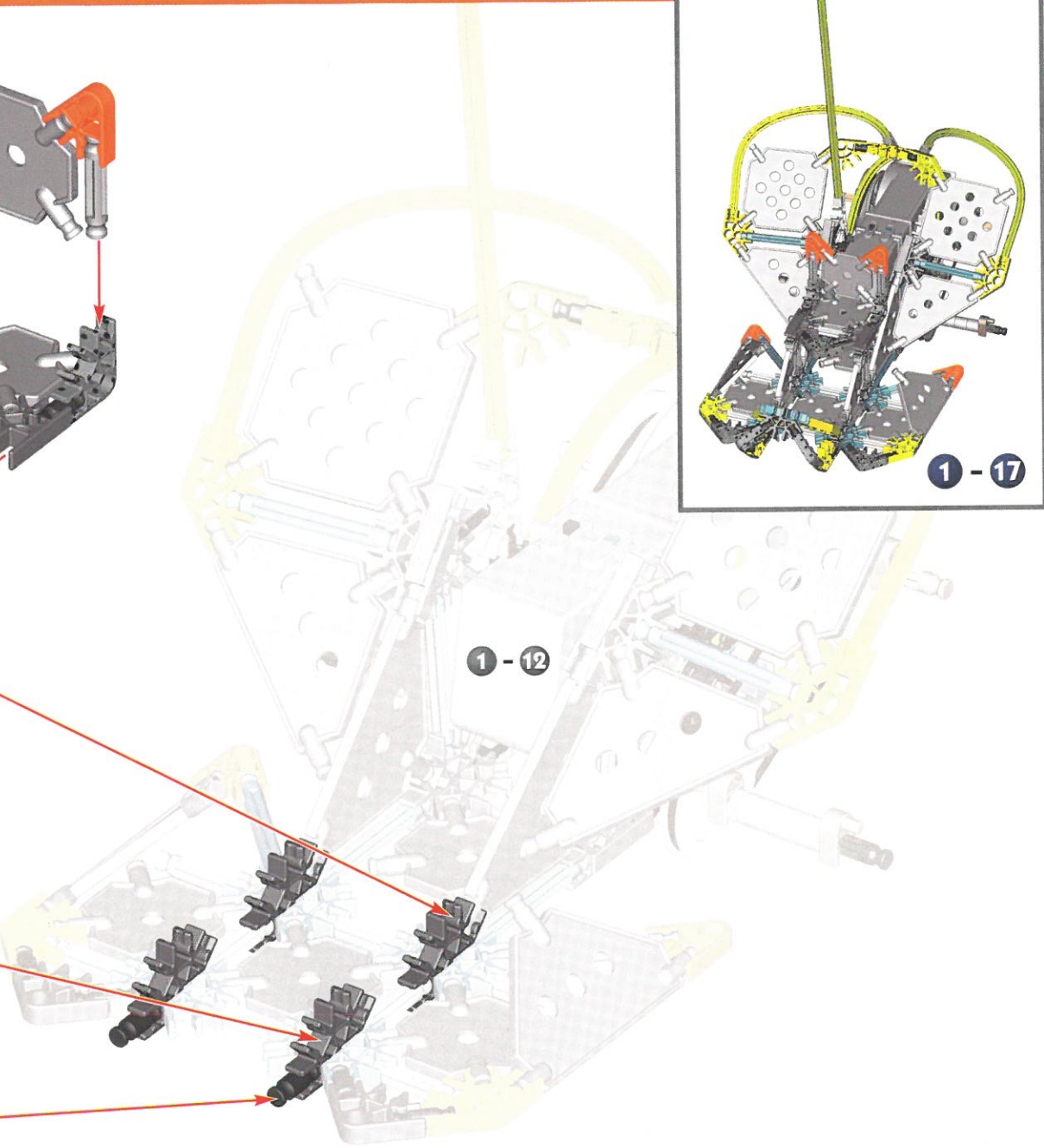
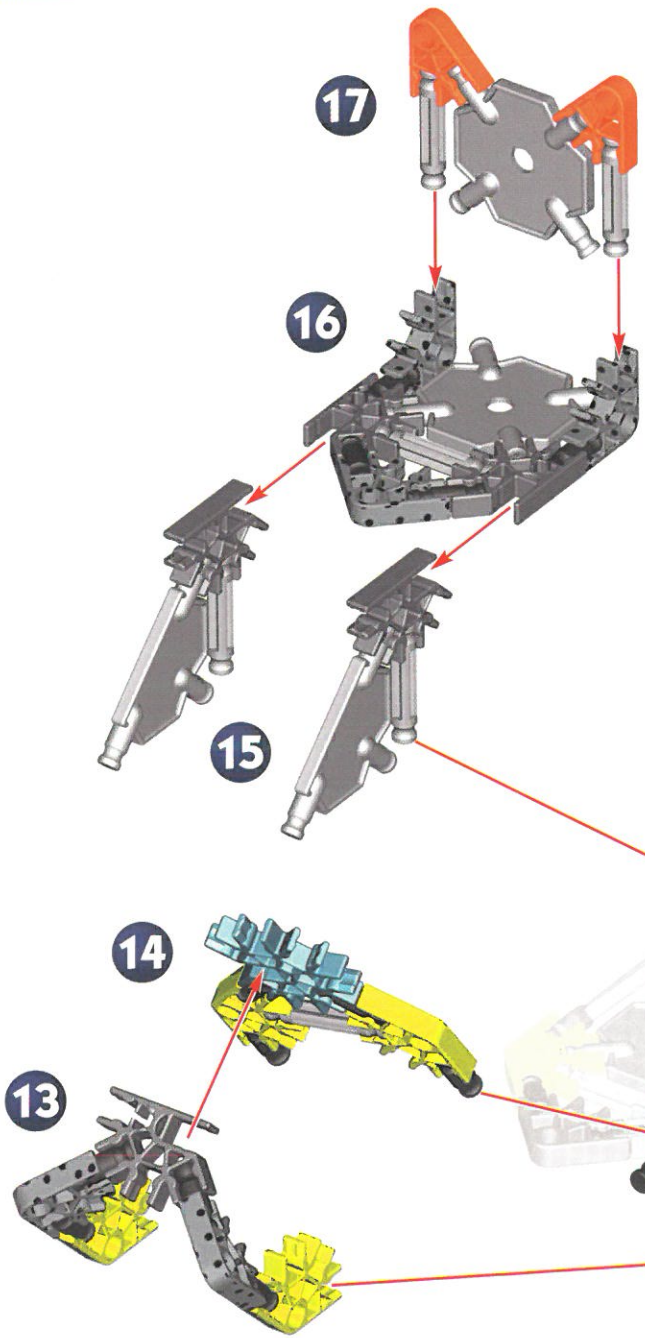

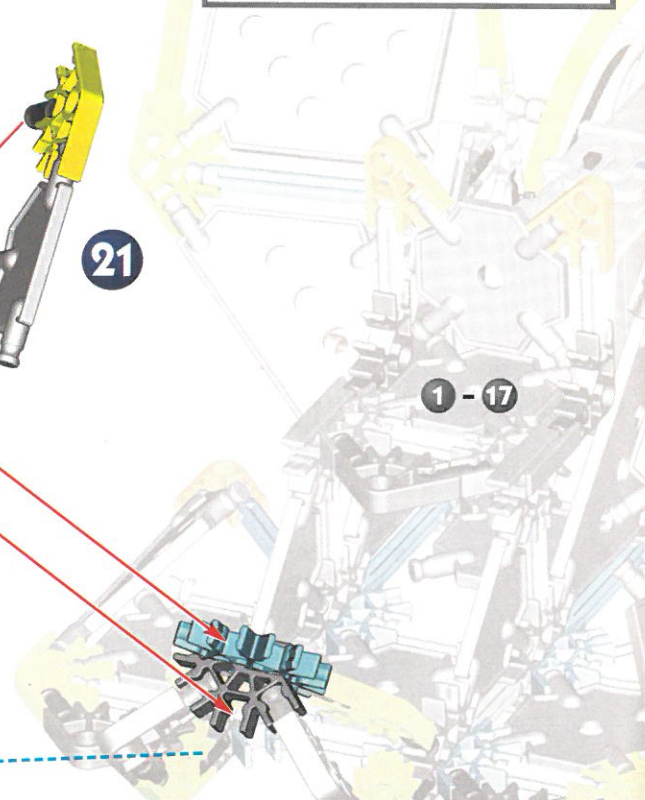
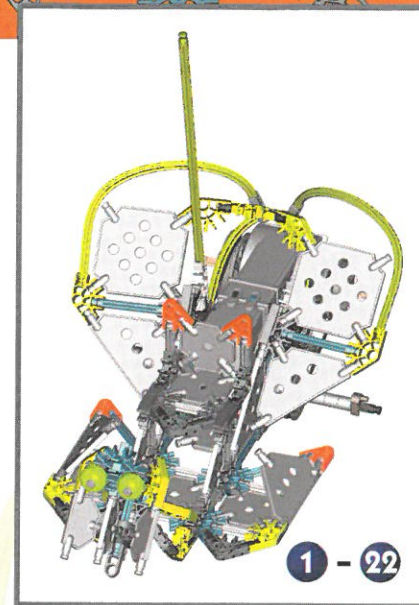
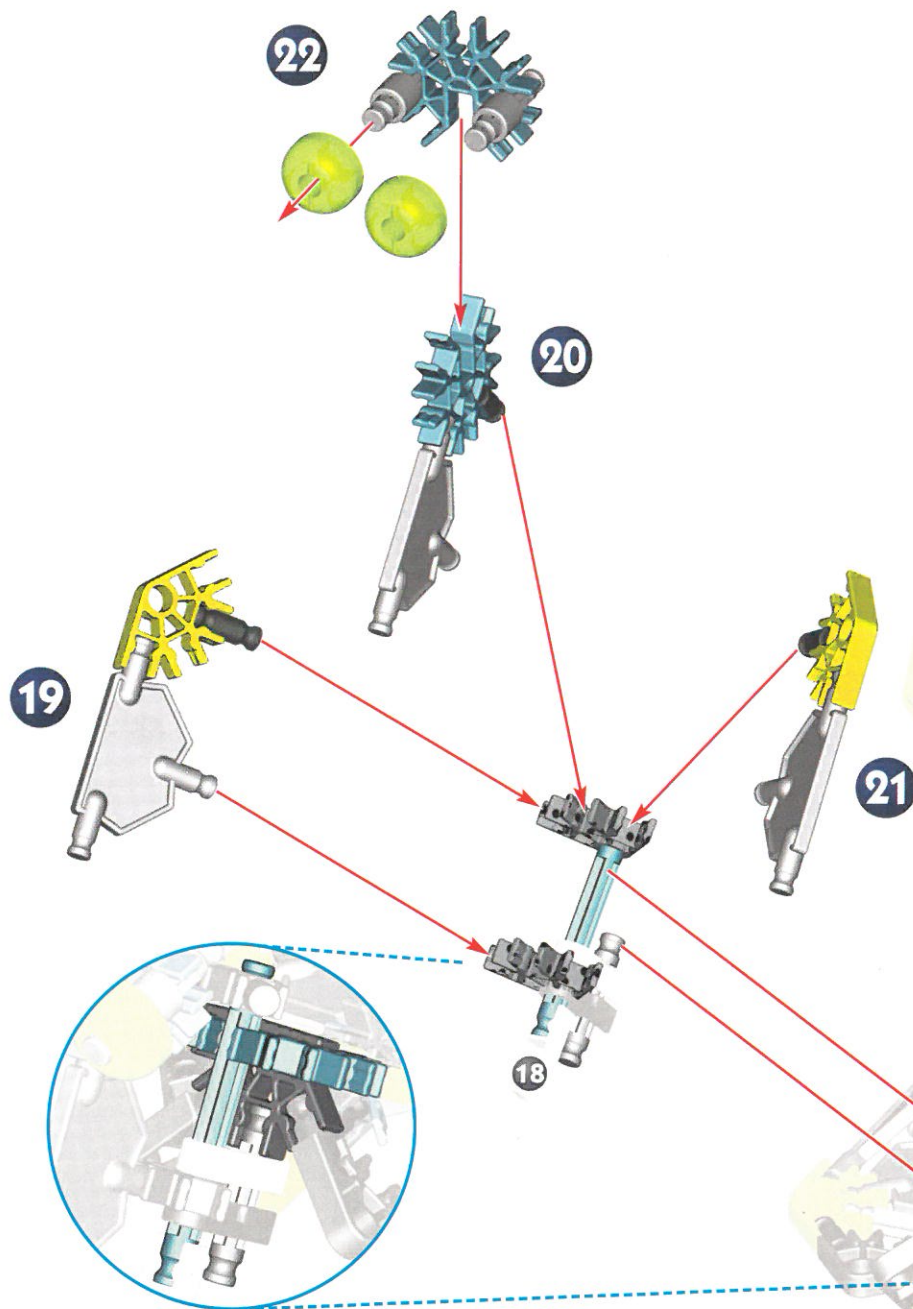
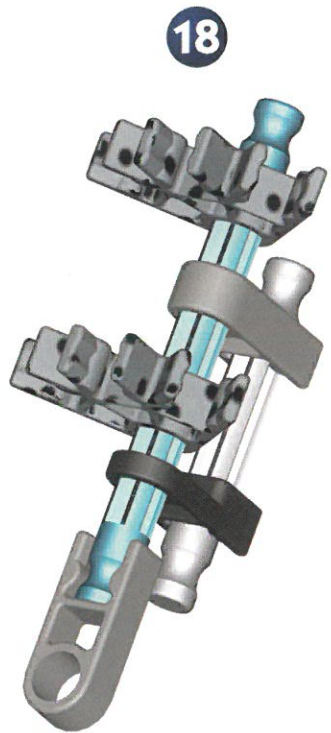

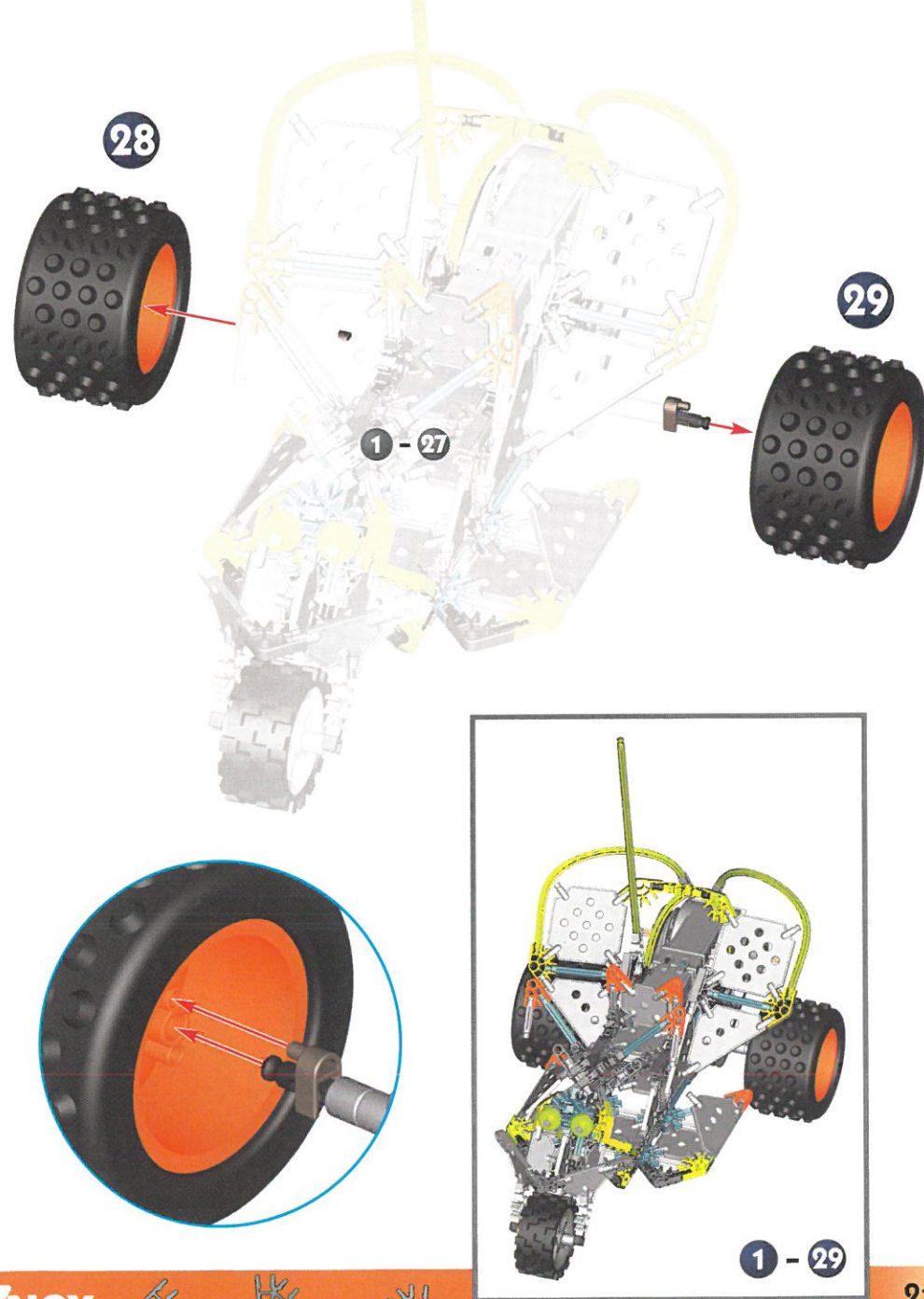
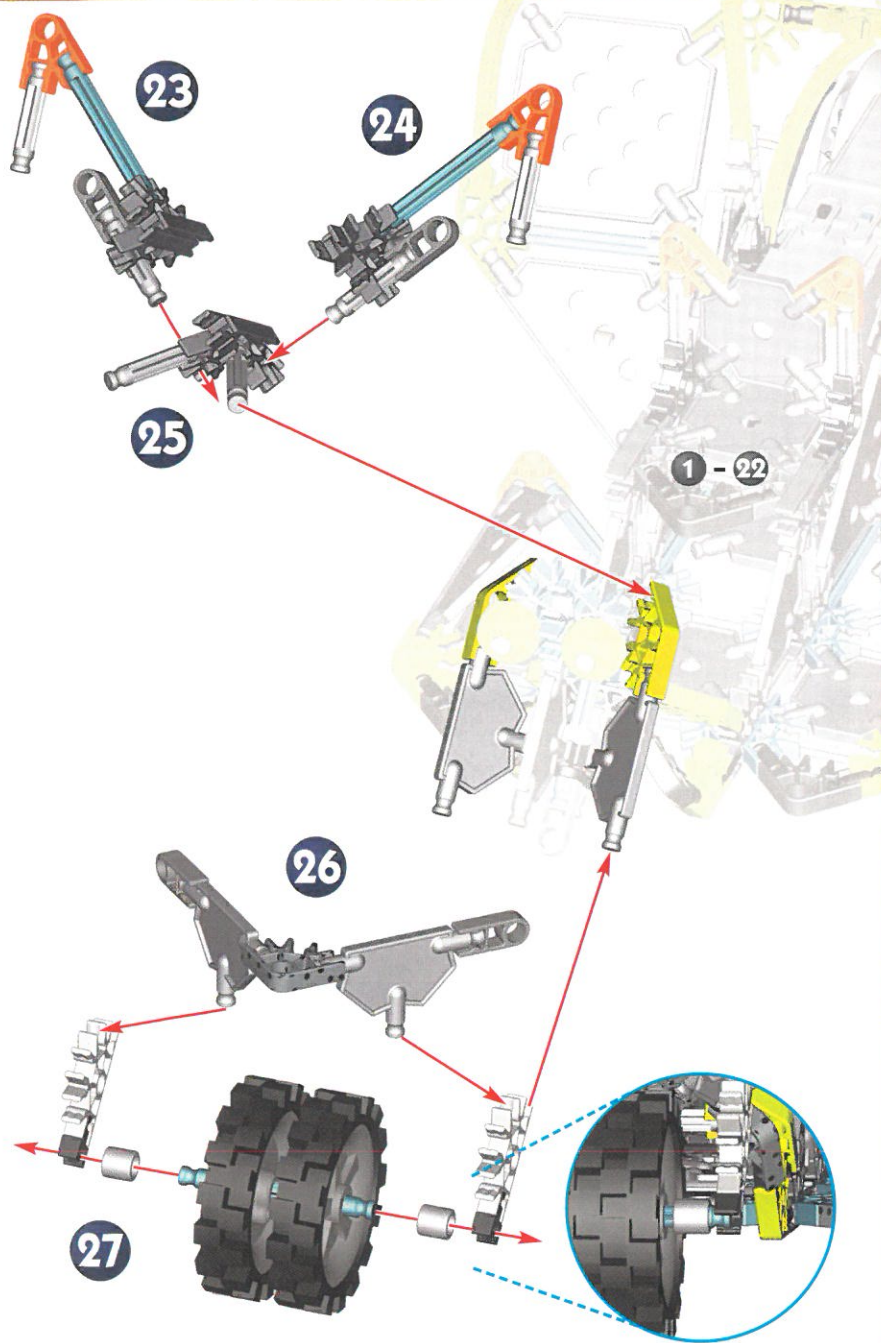

DUNE BUGGY

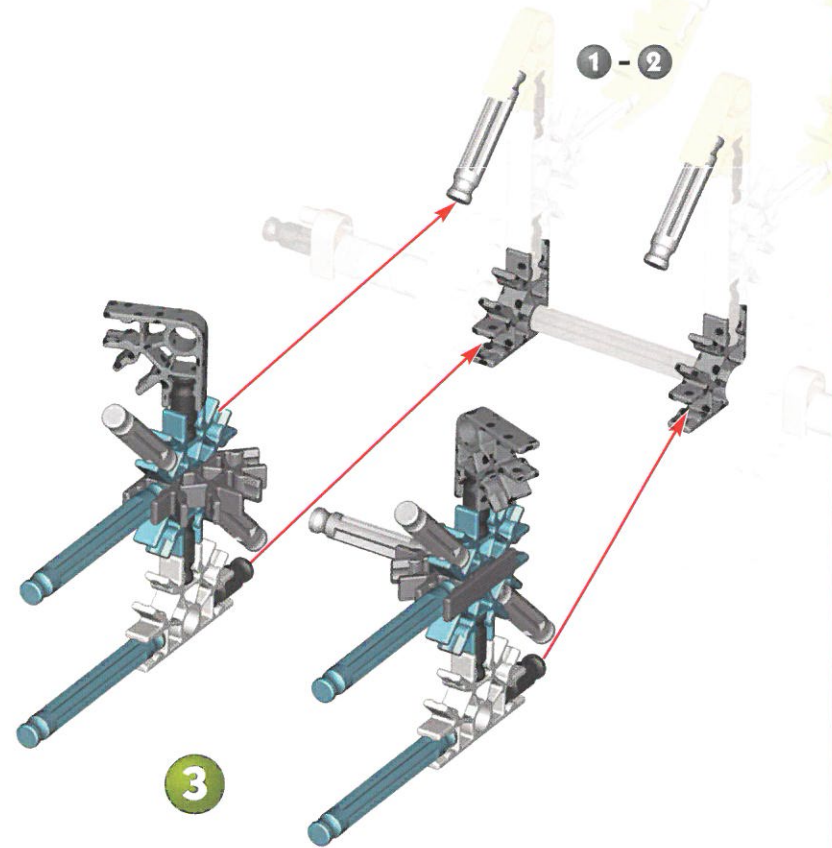
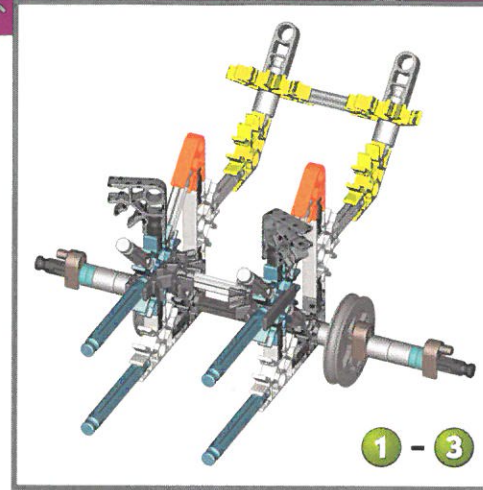
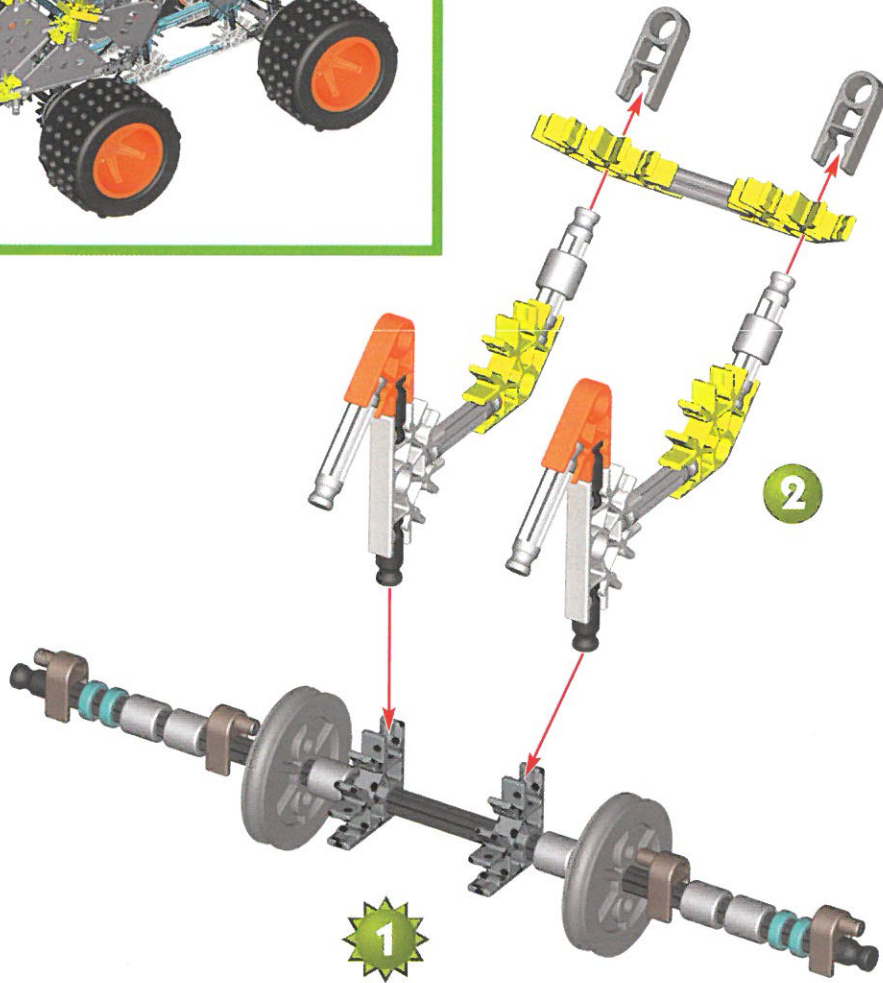
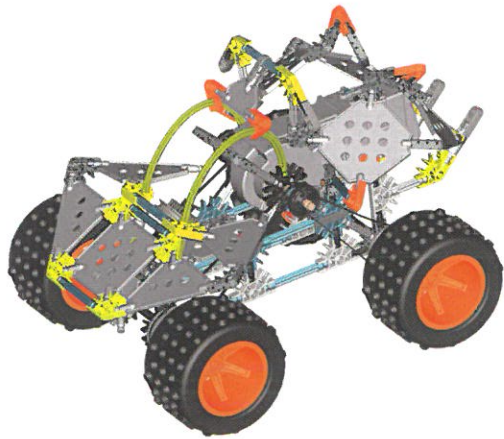

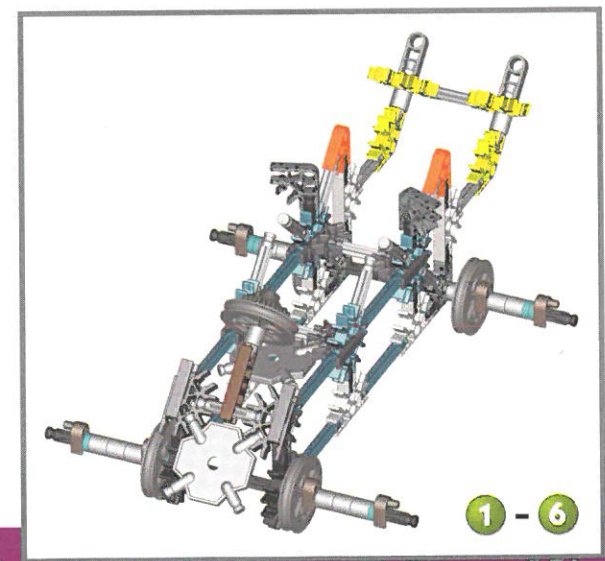
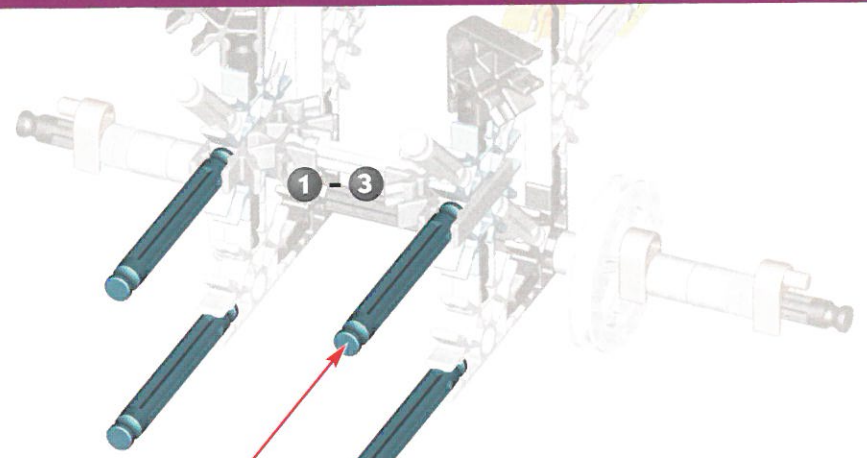
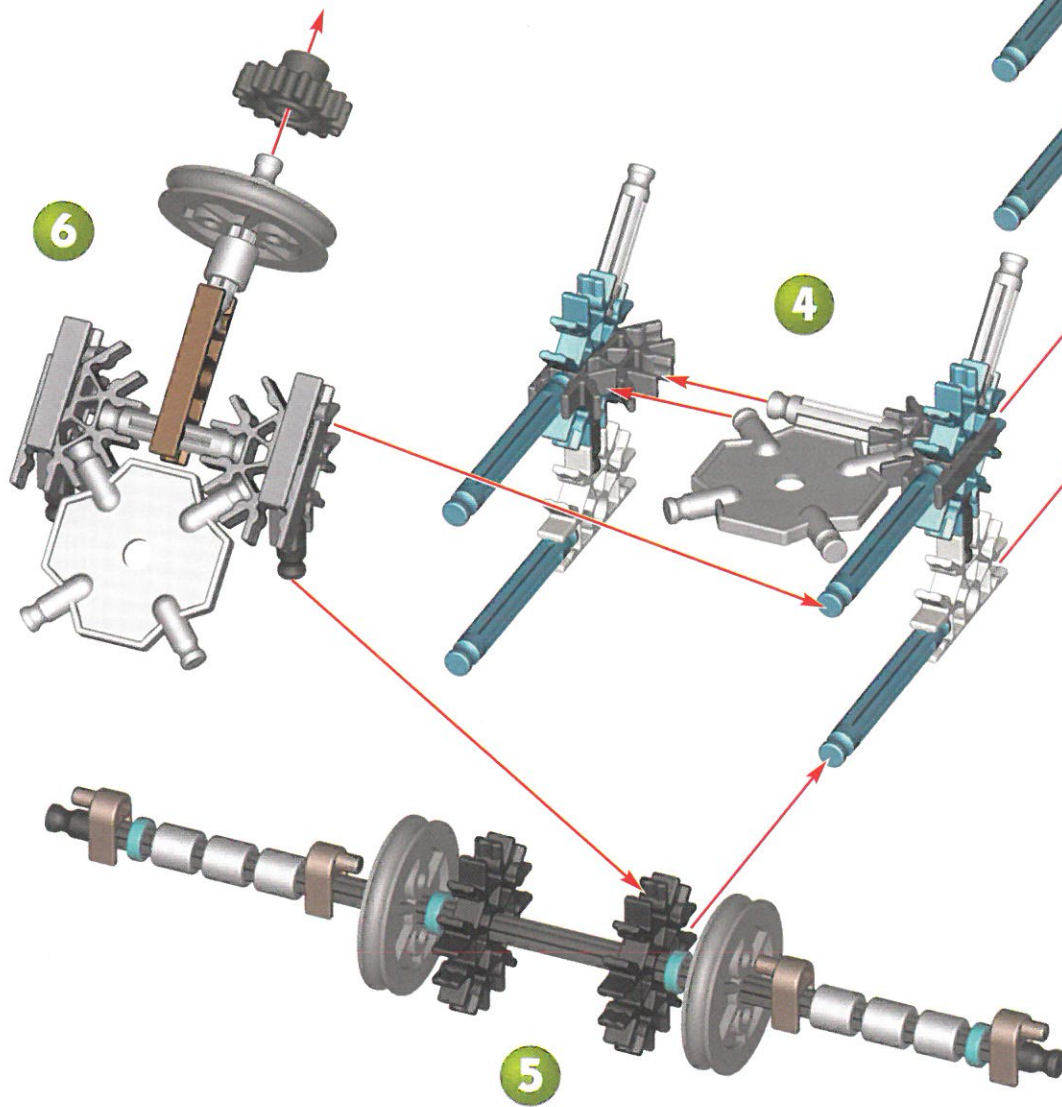

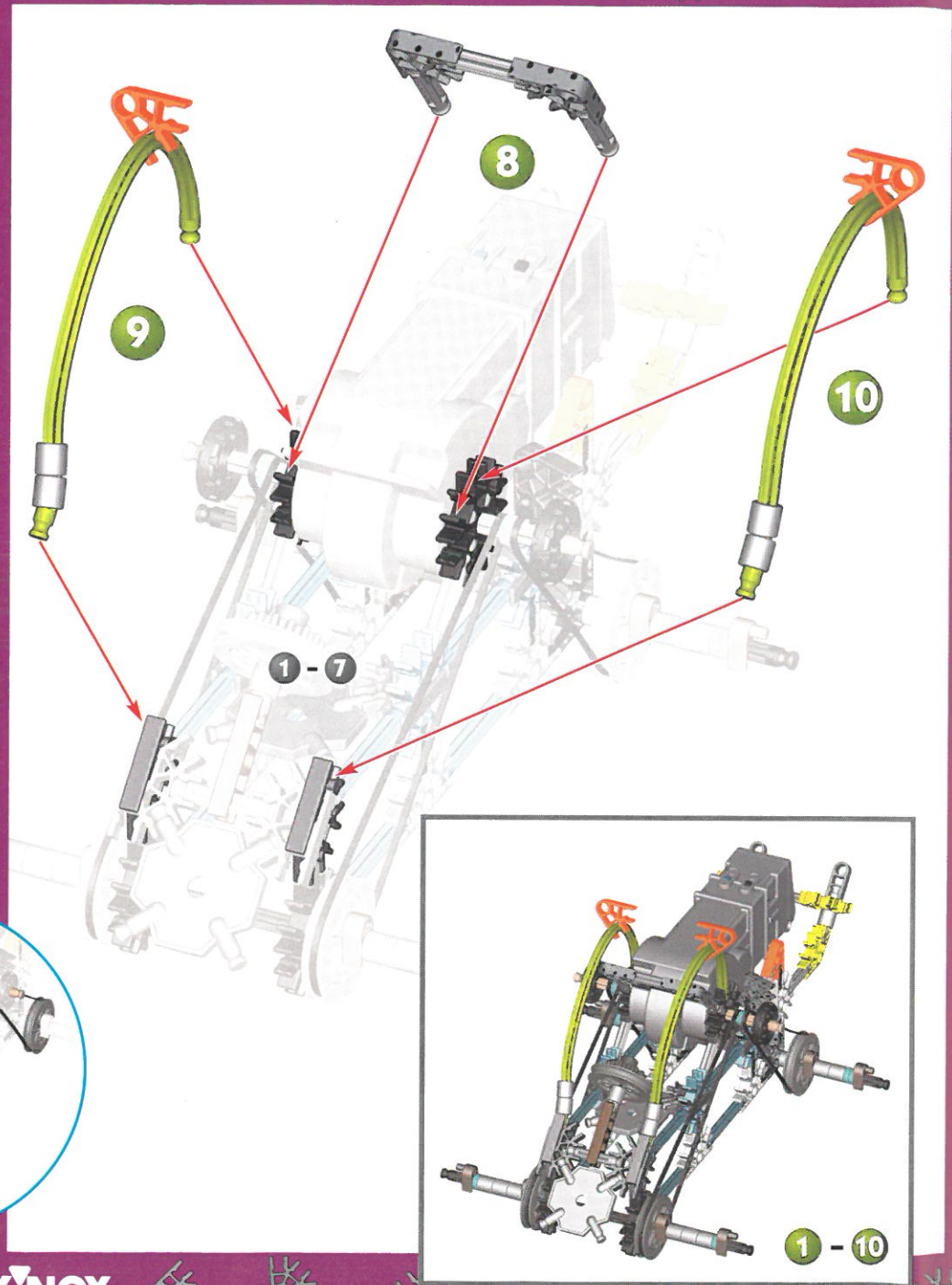
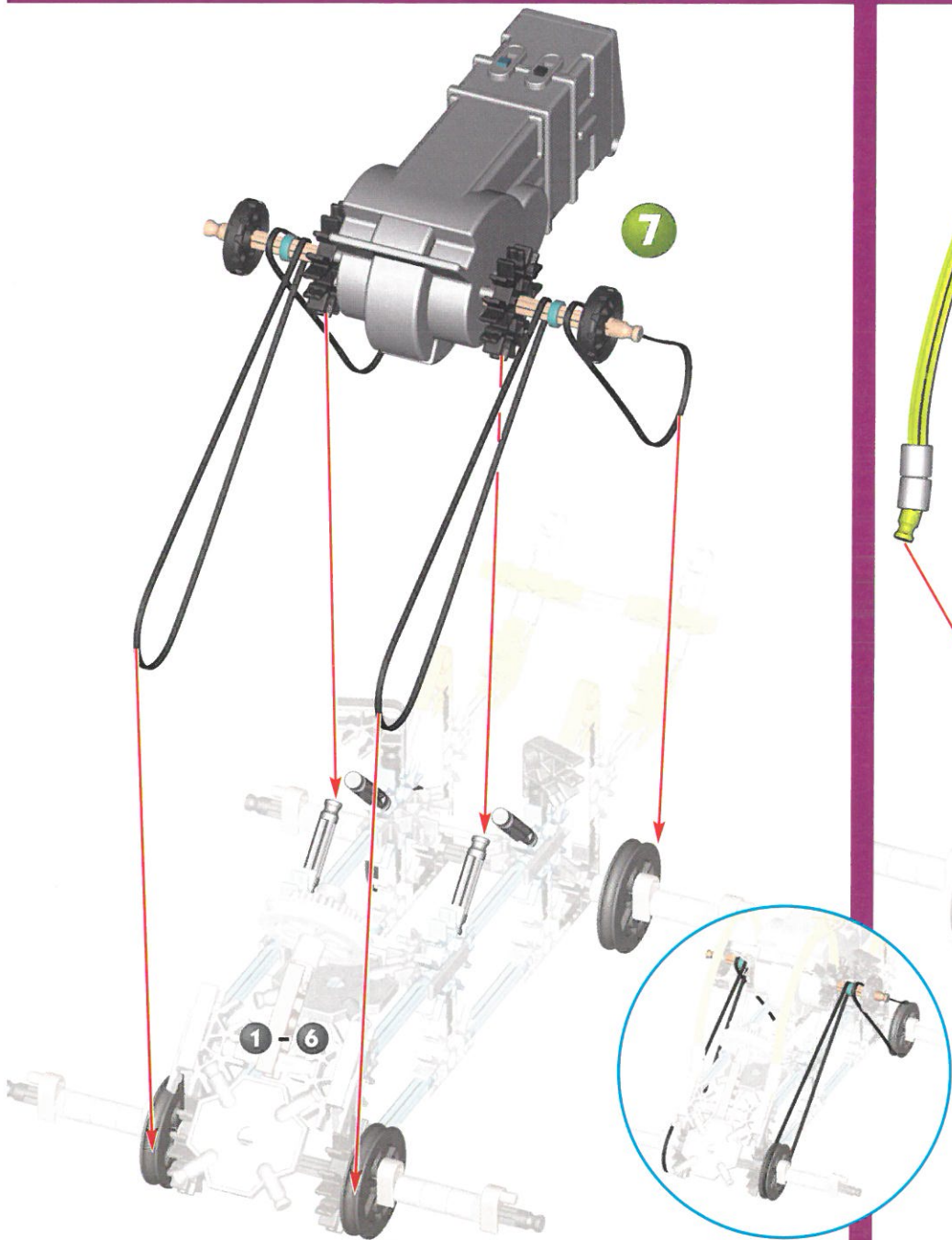

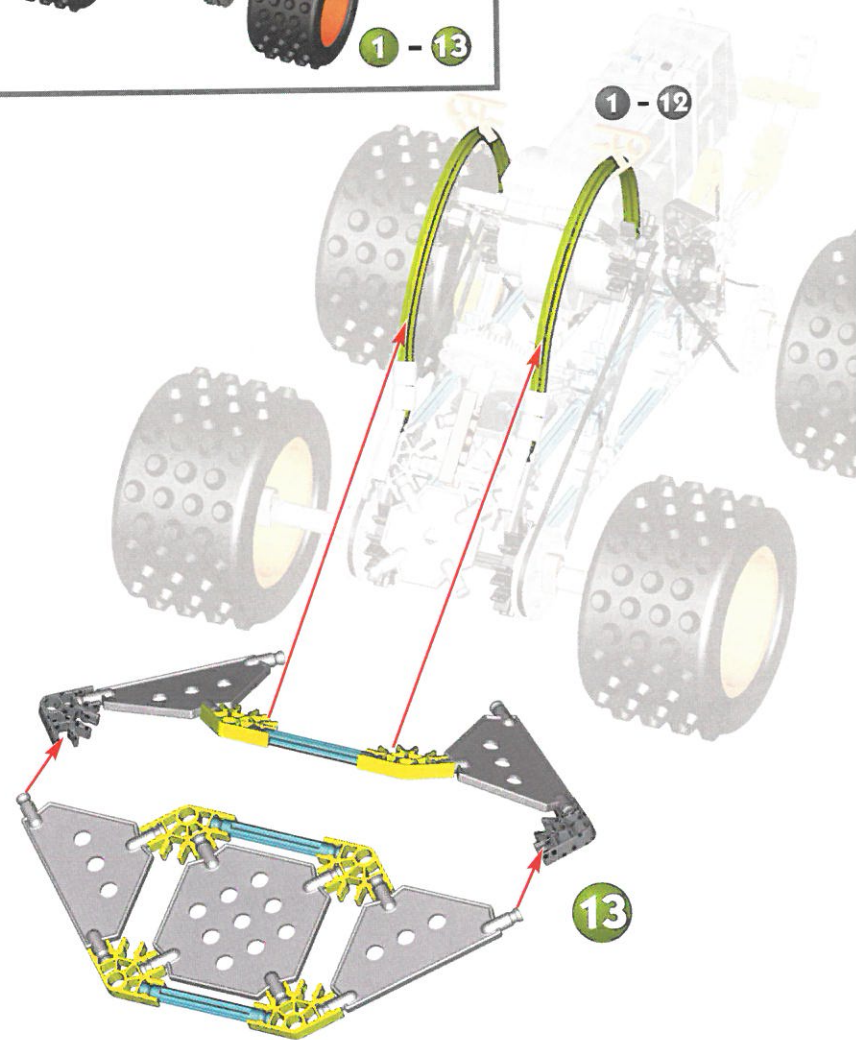
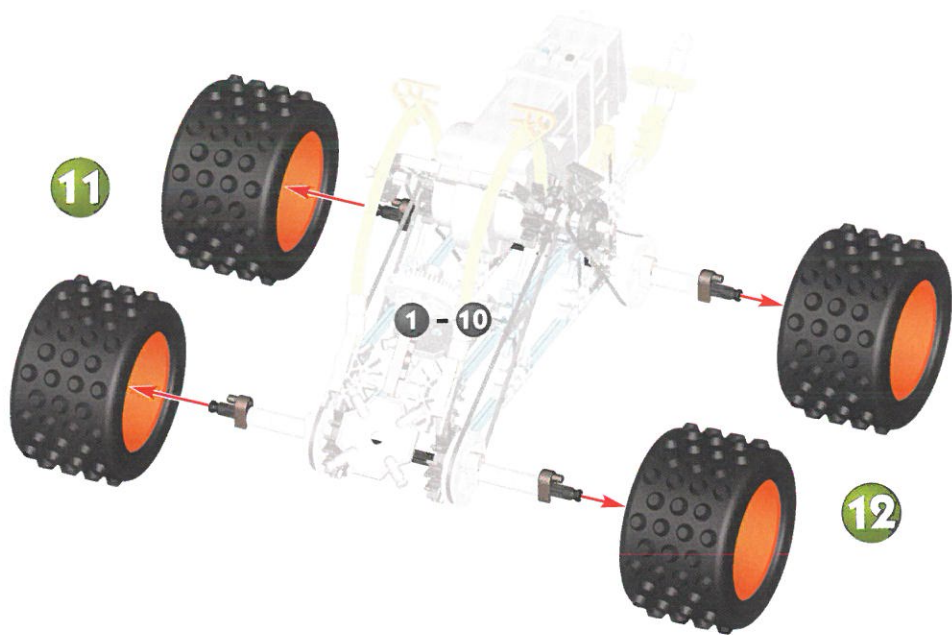
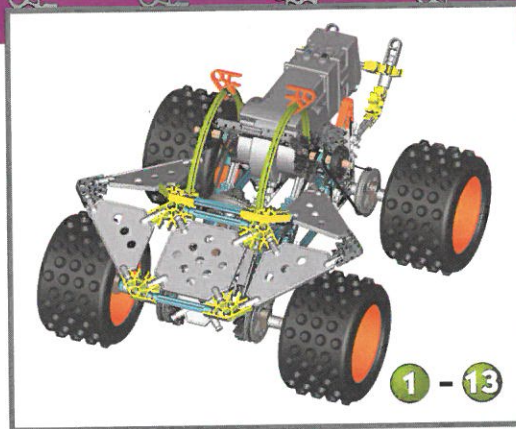
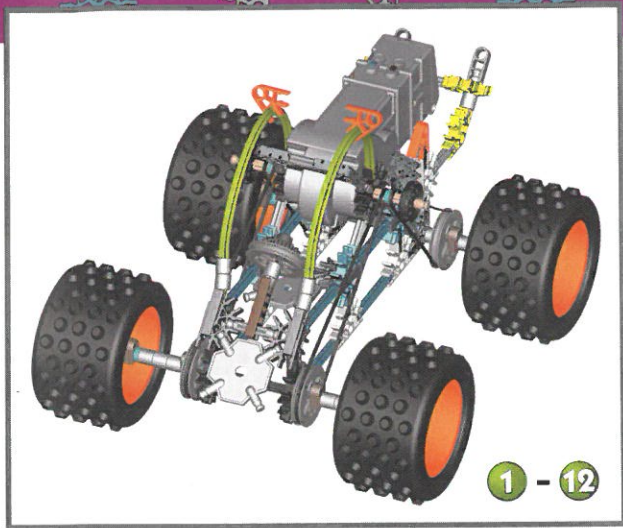

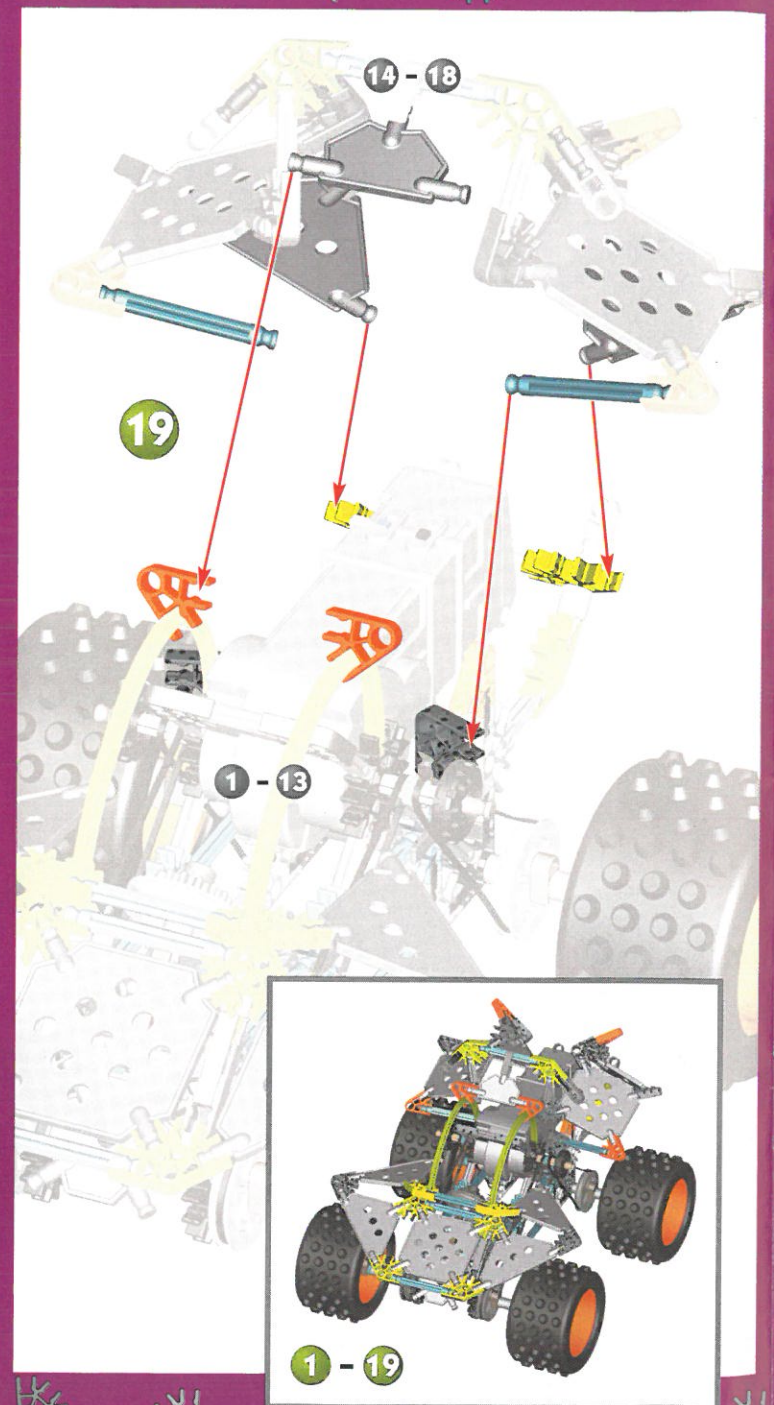
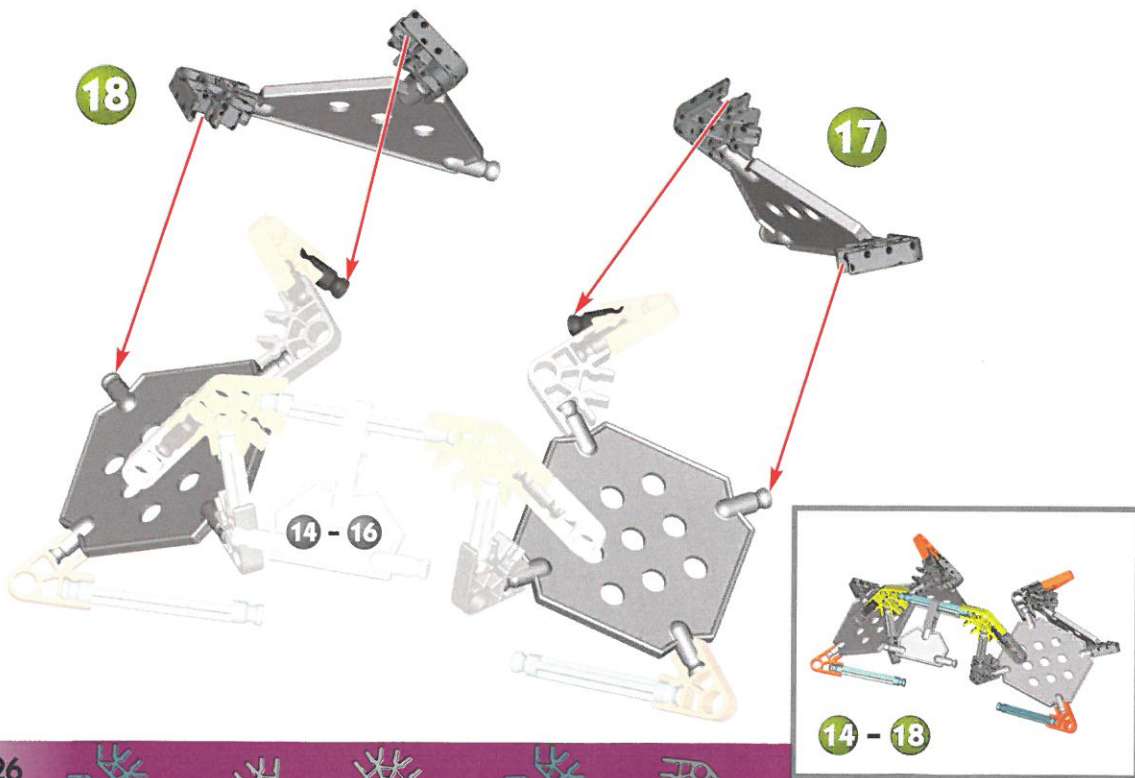
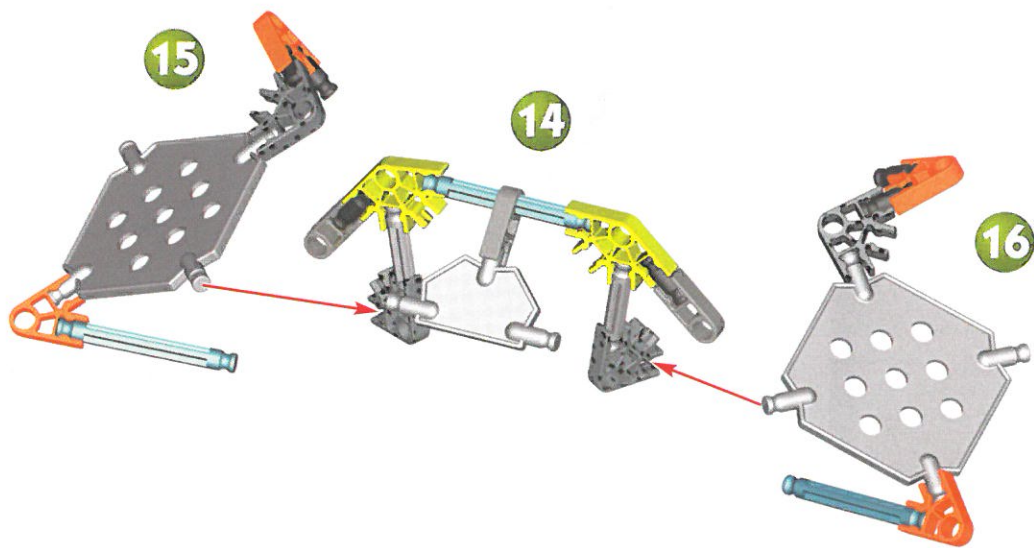

TRACTOR TRUCK

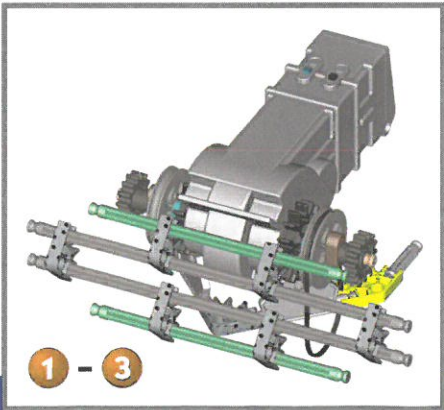
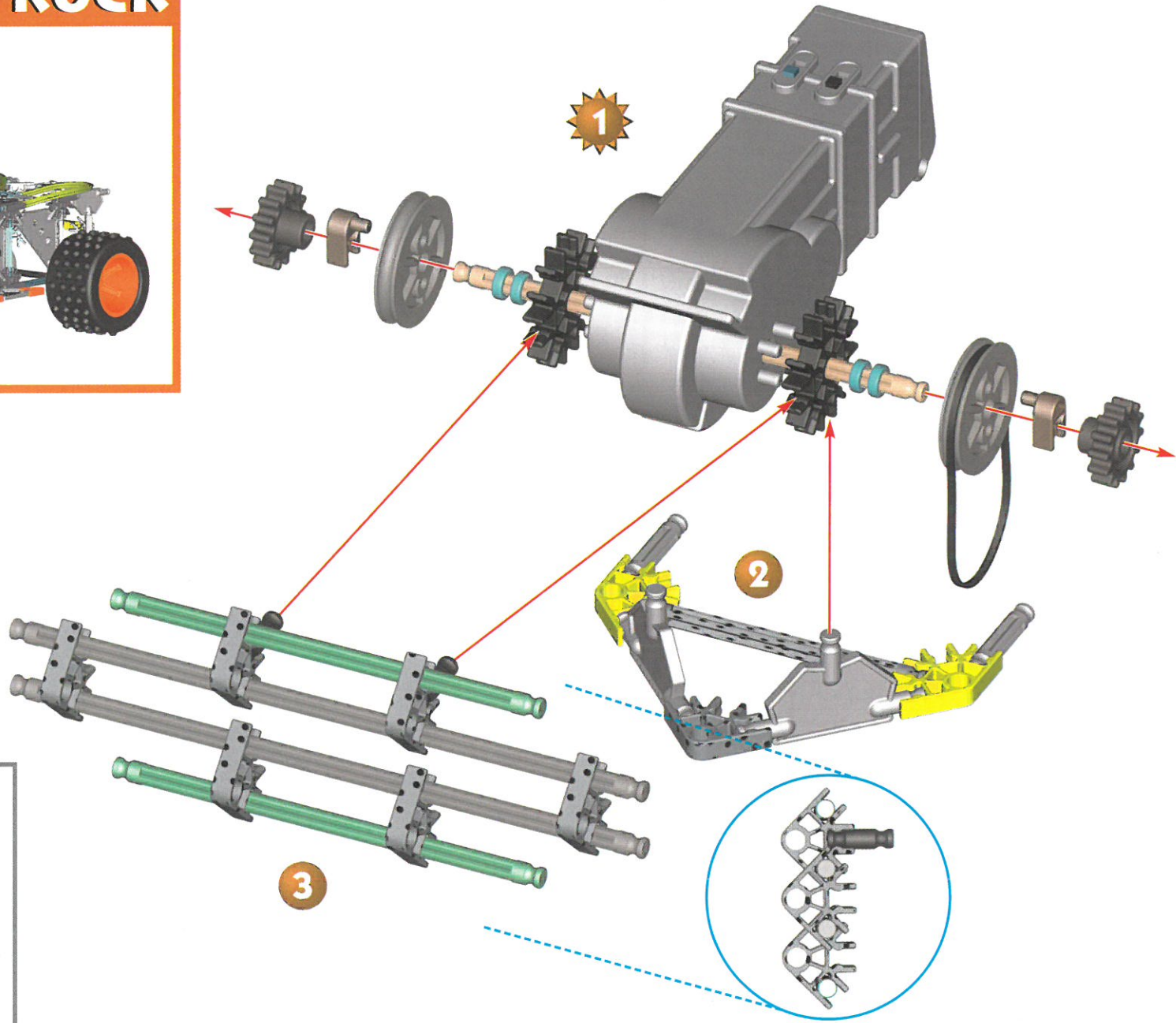
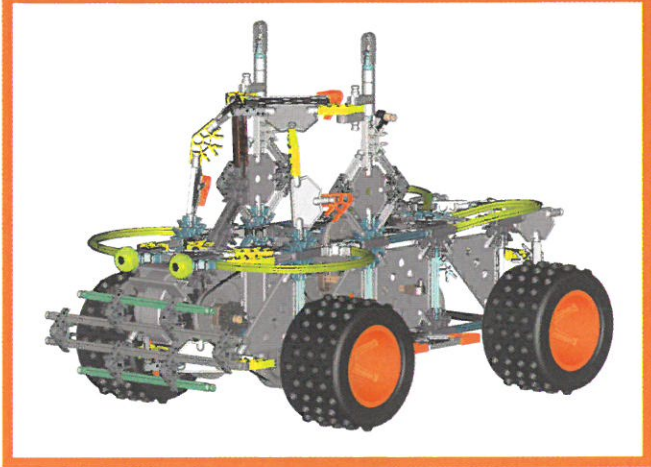

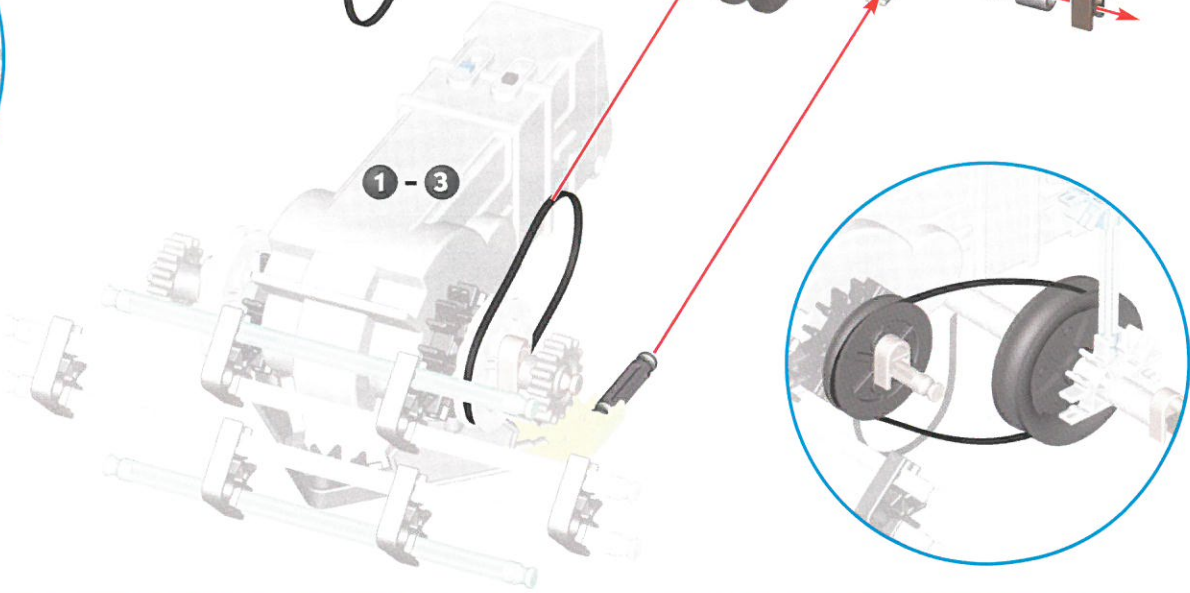
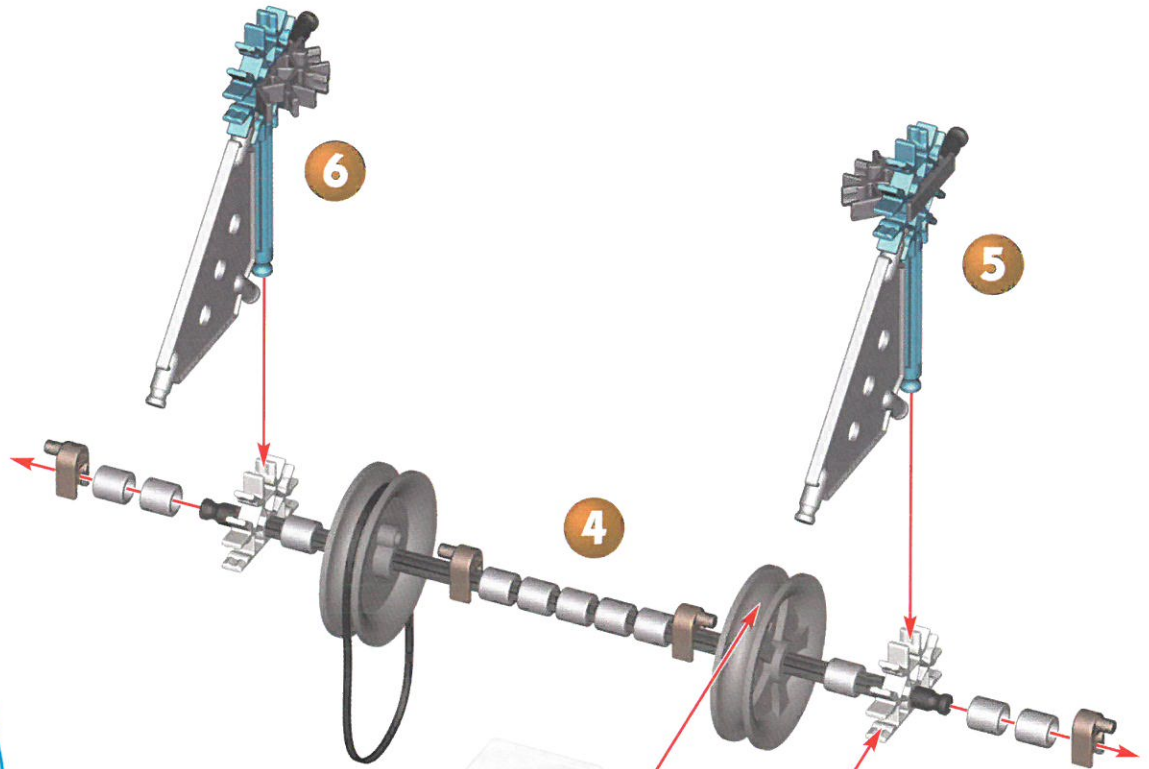
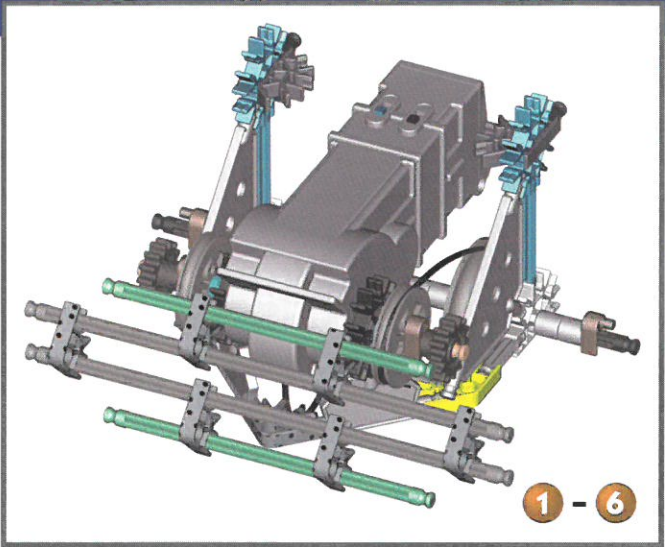

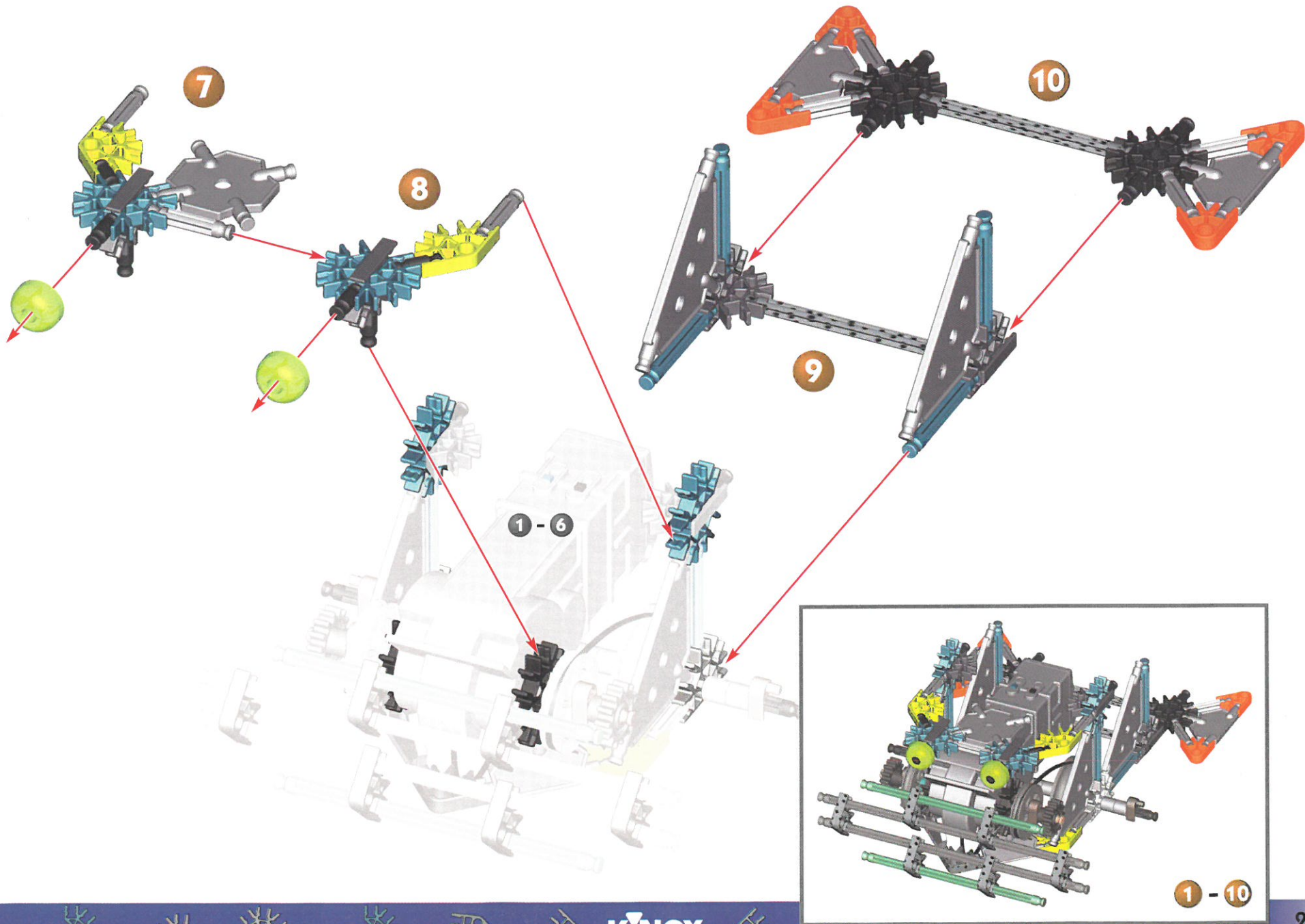

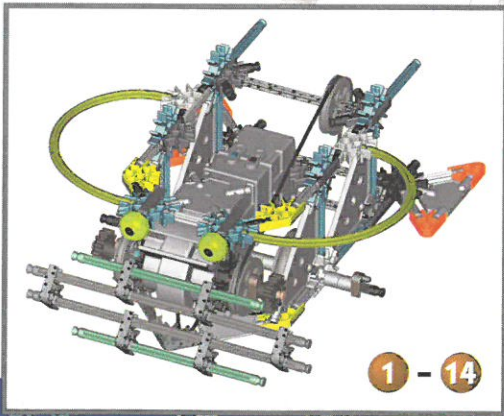
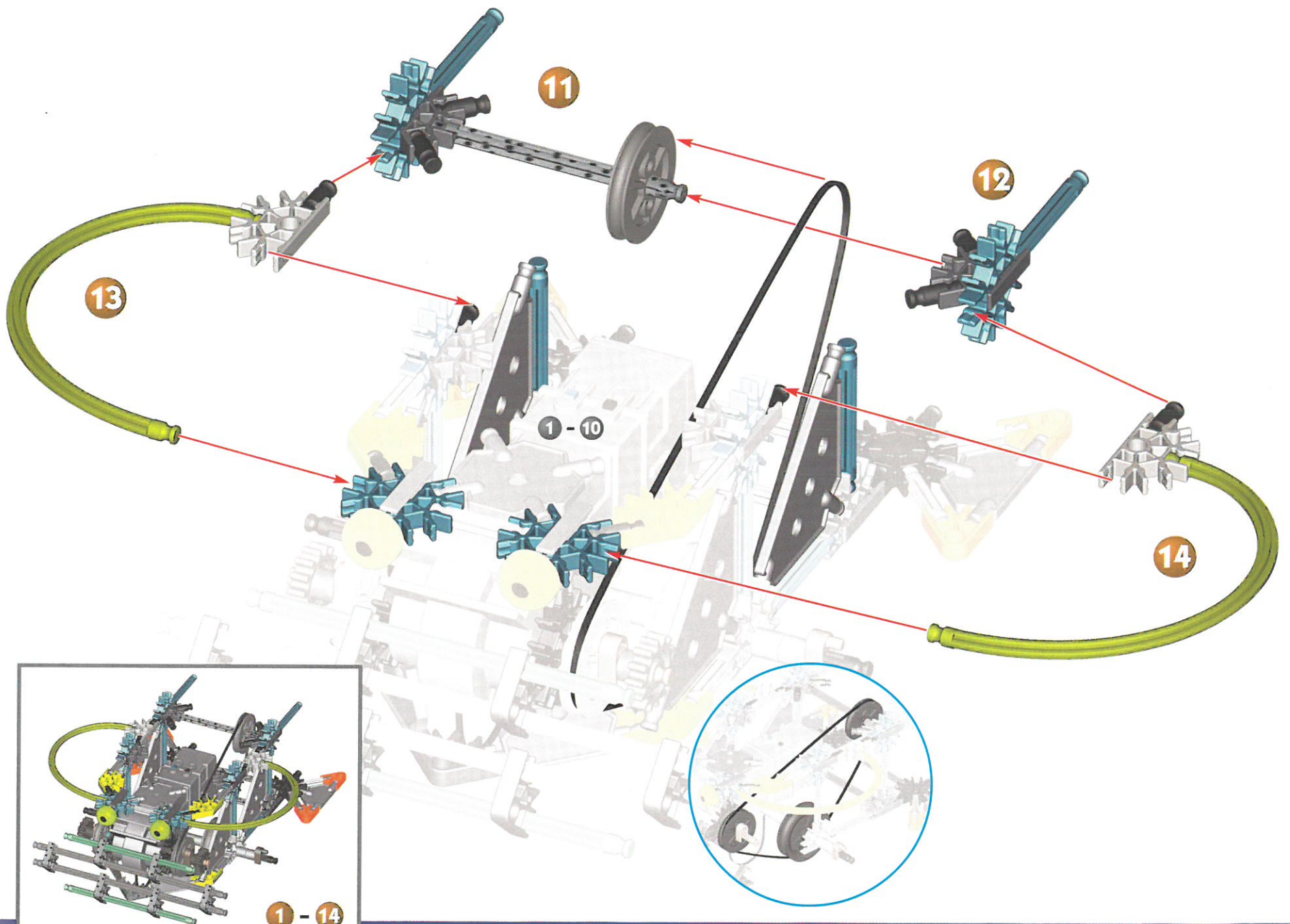

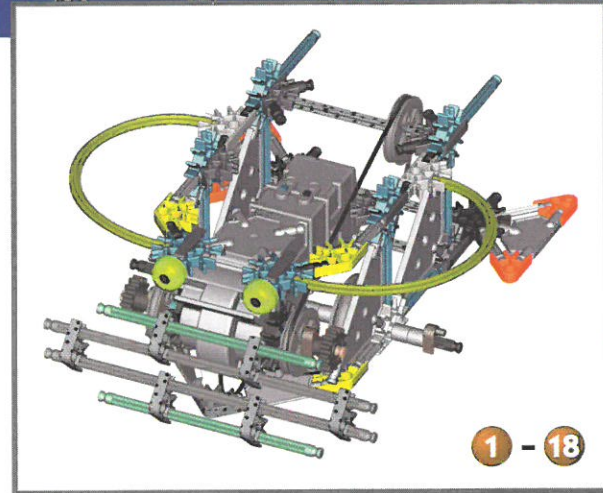
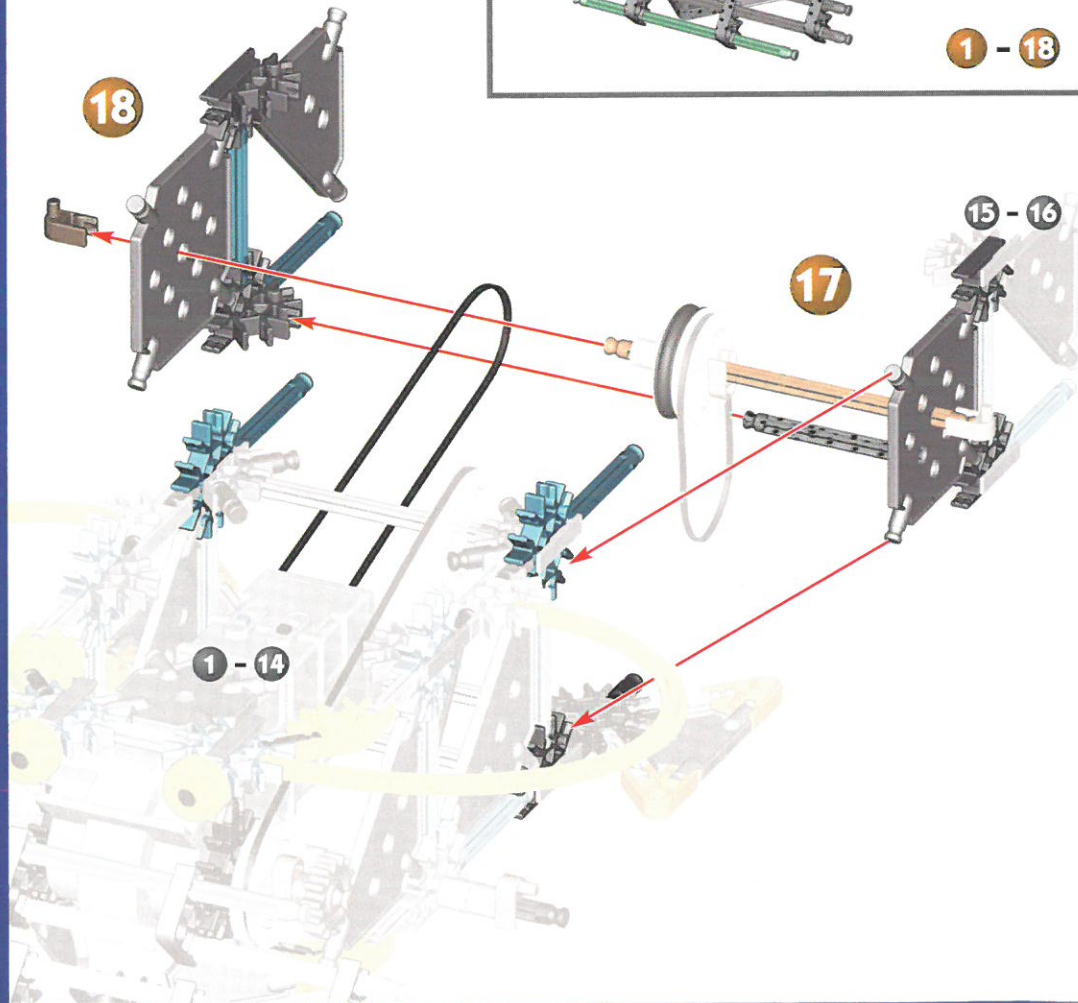
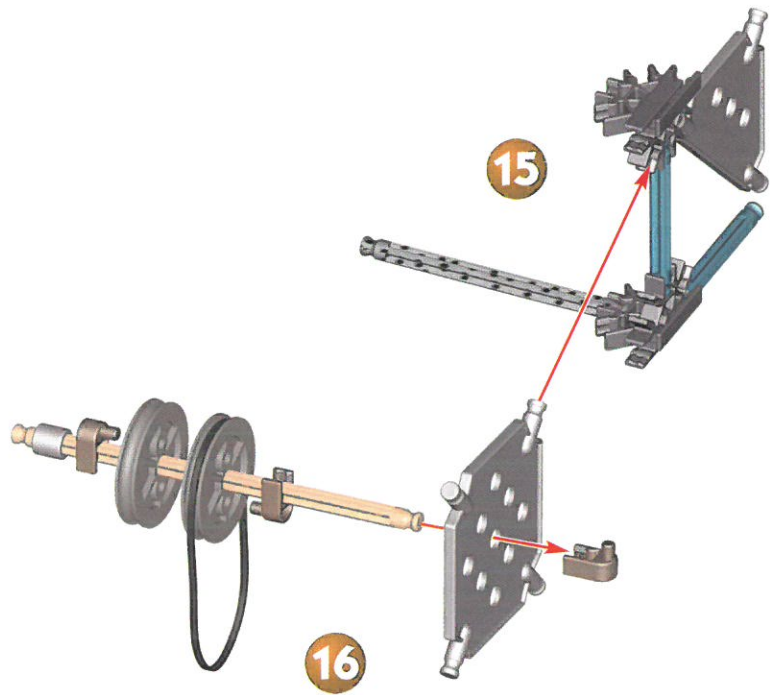

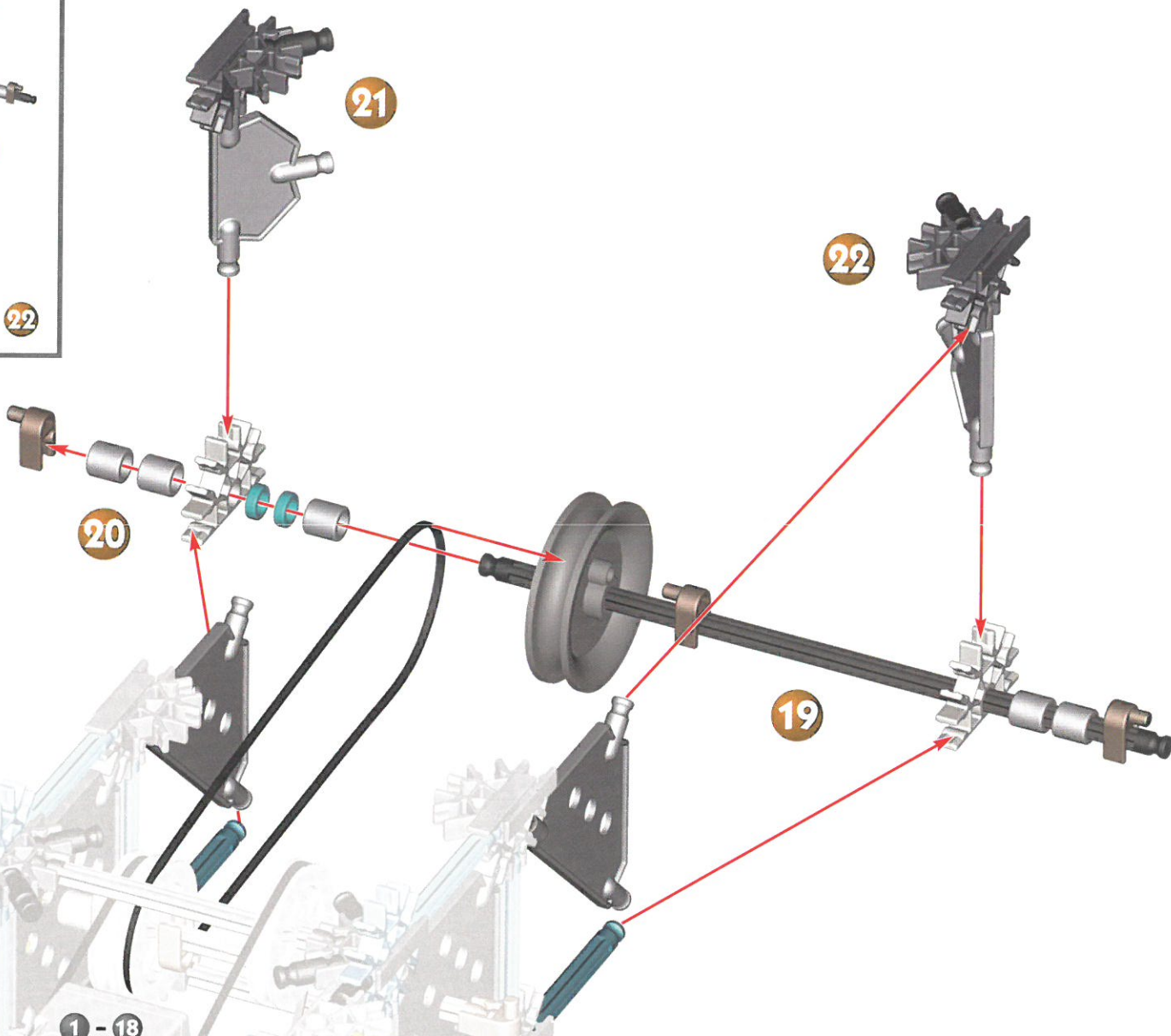
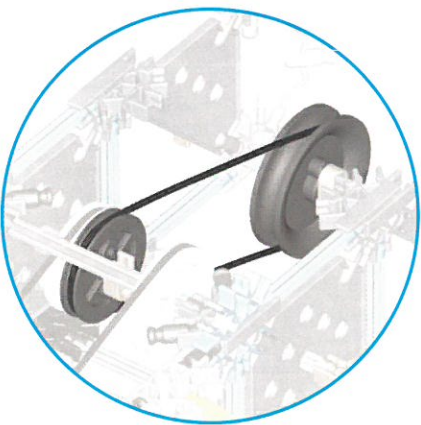
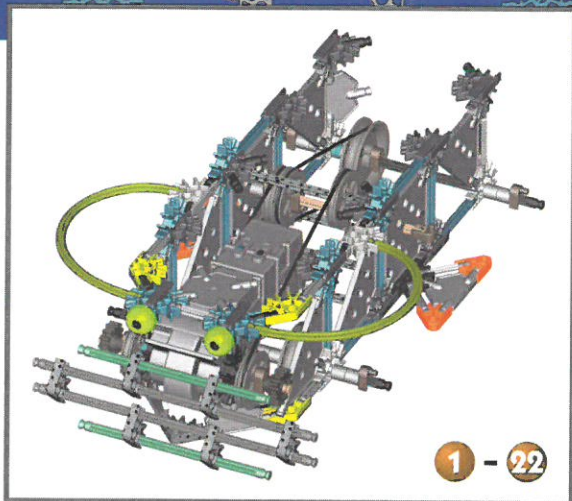

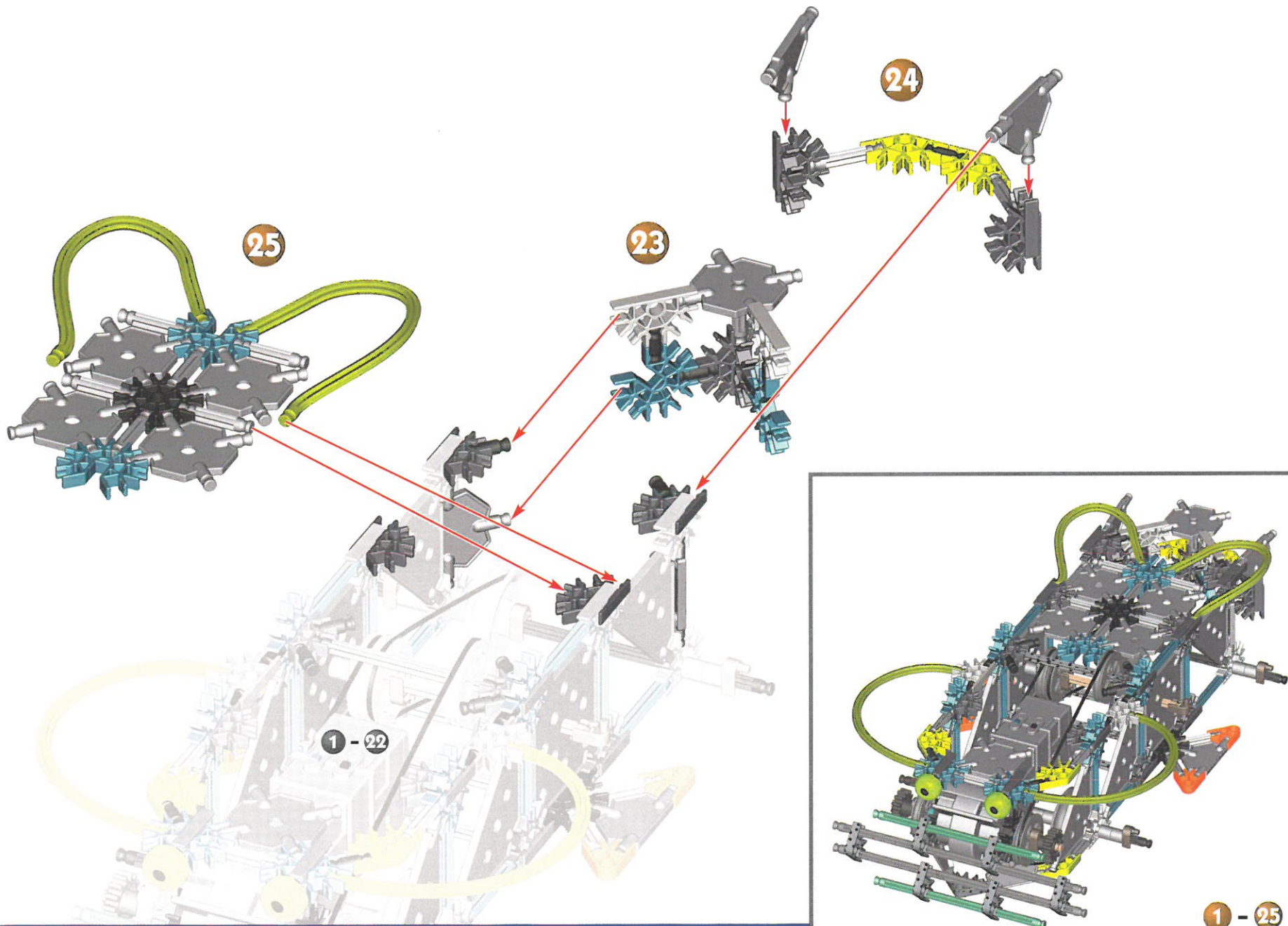

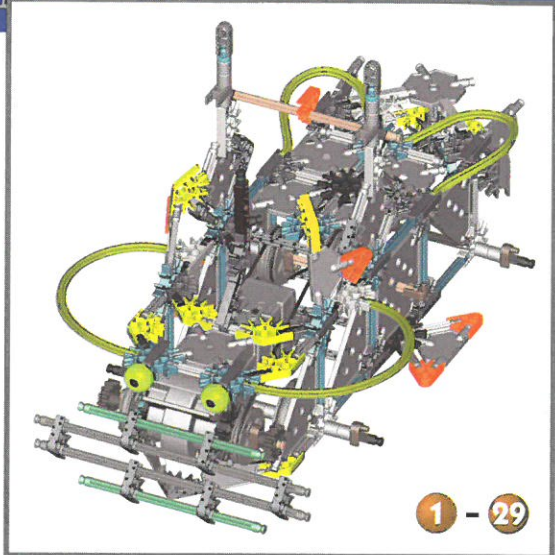
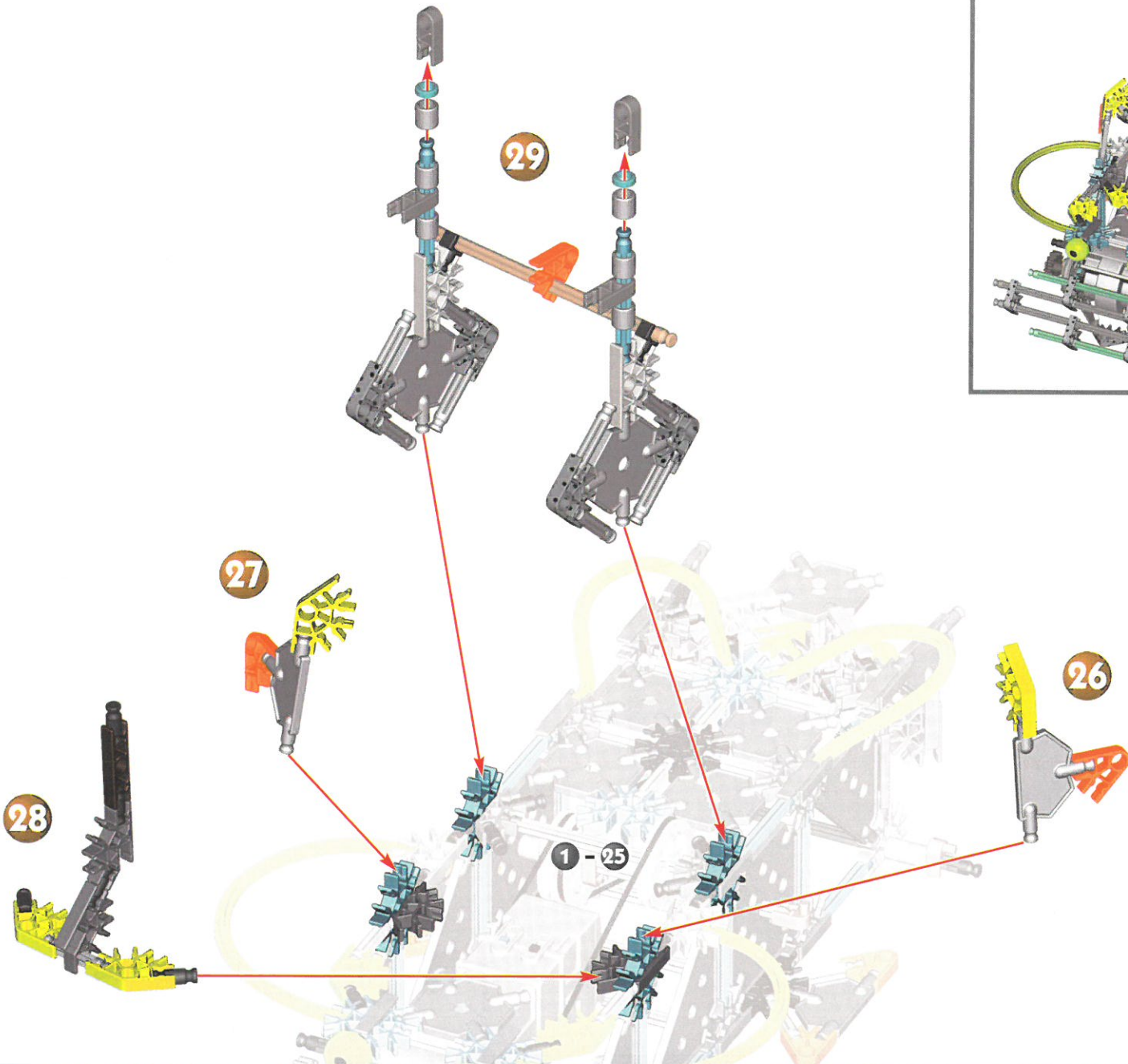
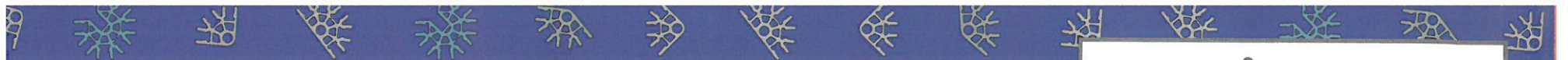

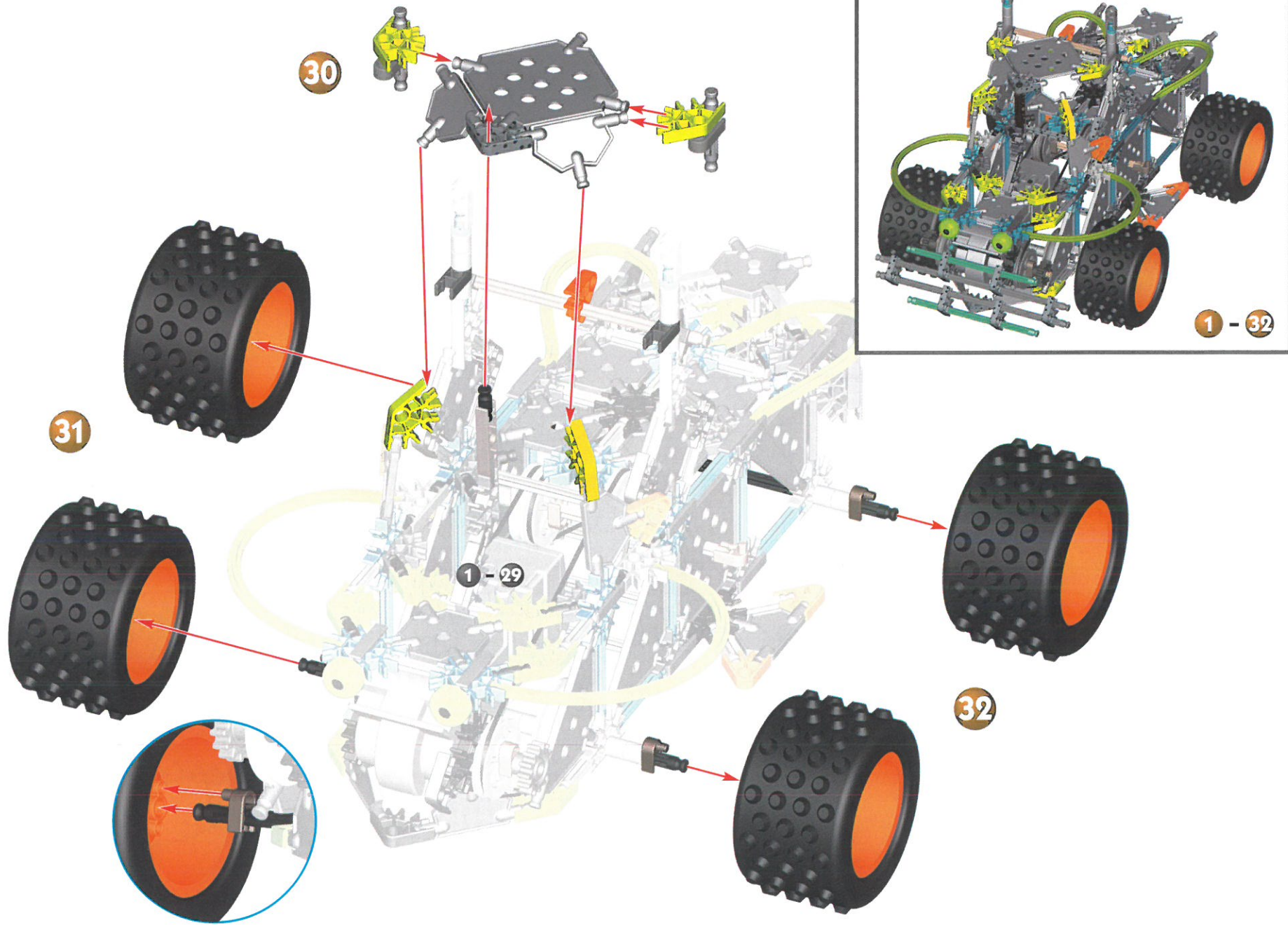

QUAD

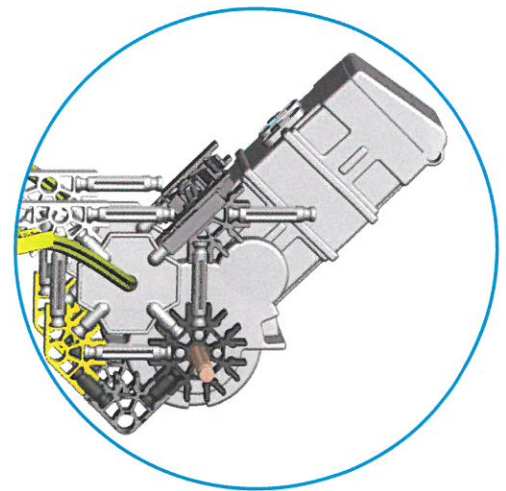
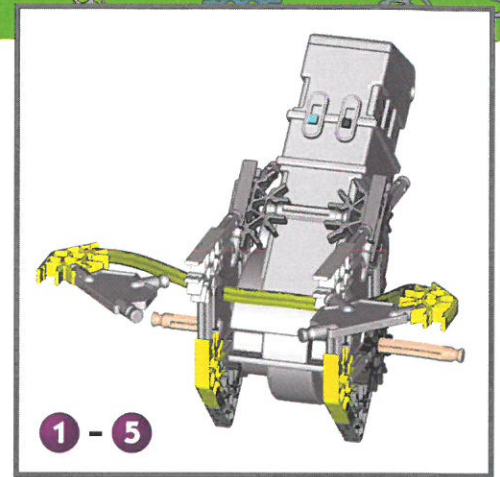
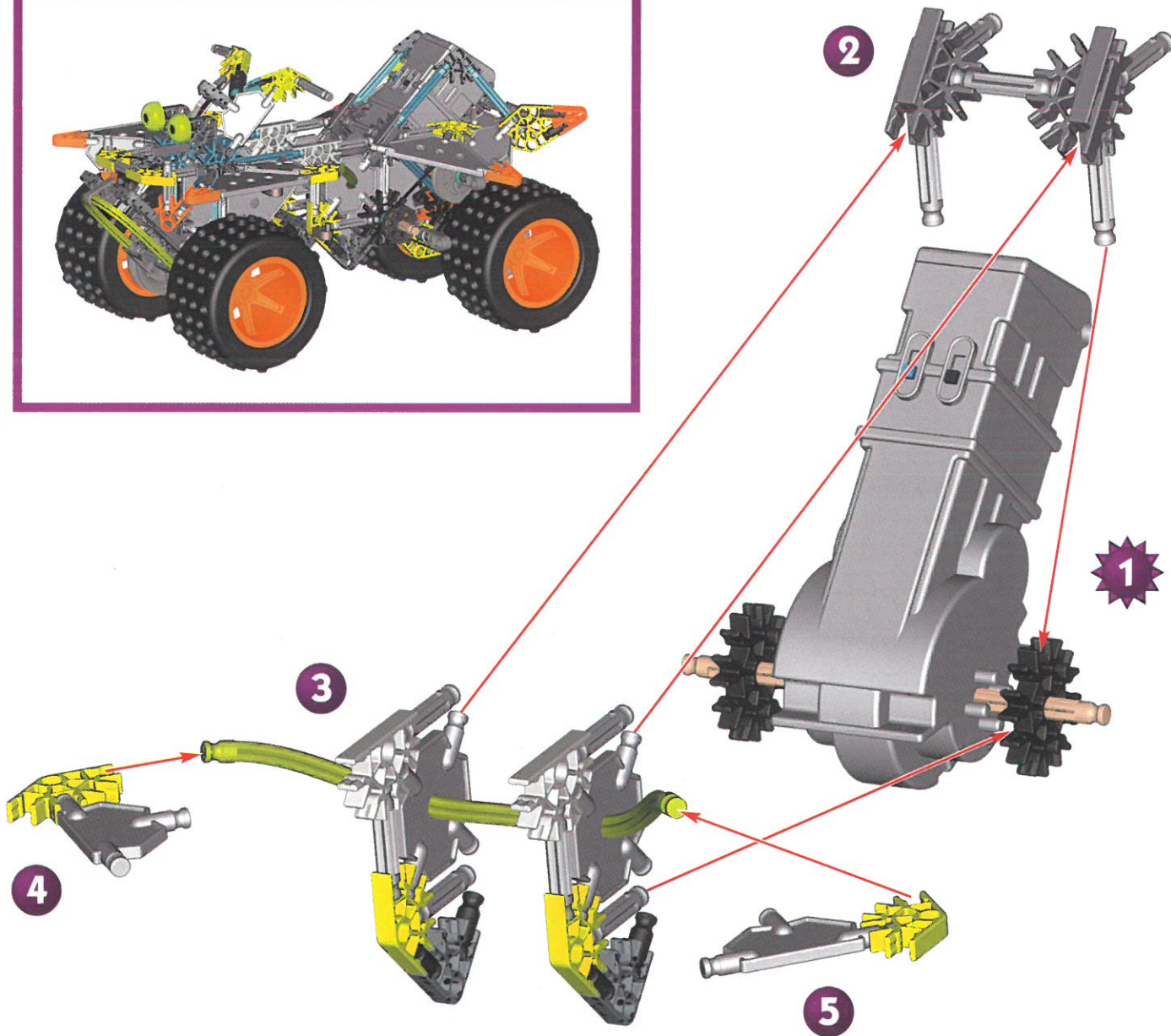
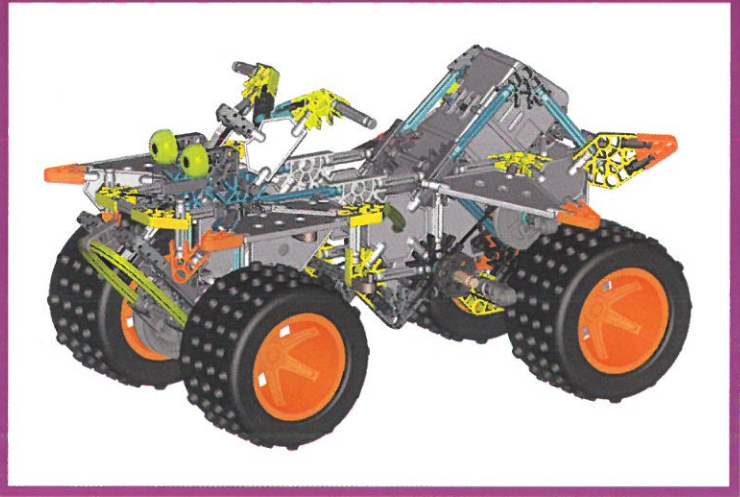

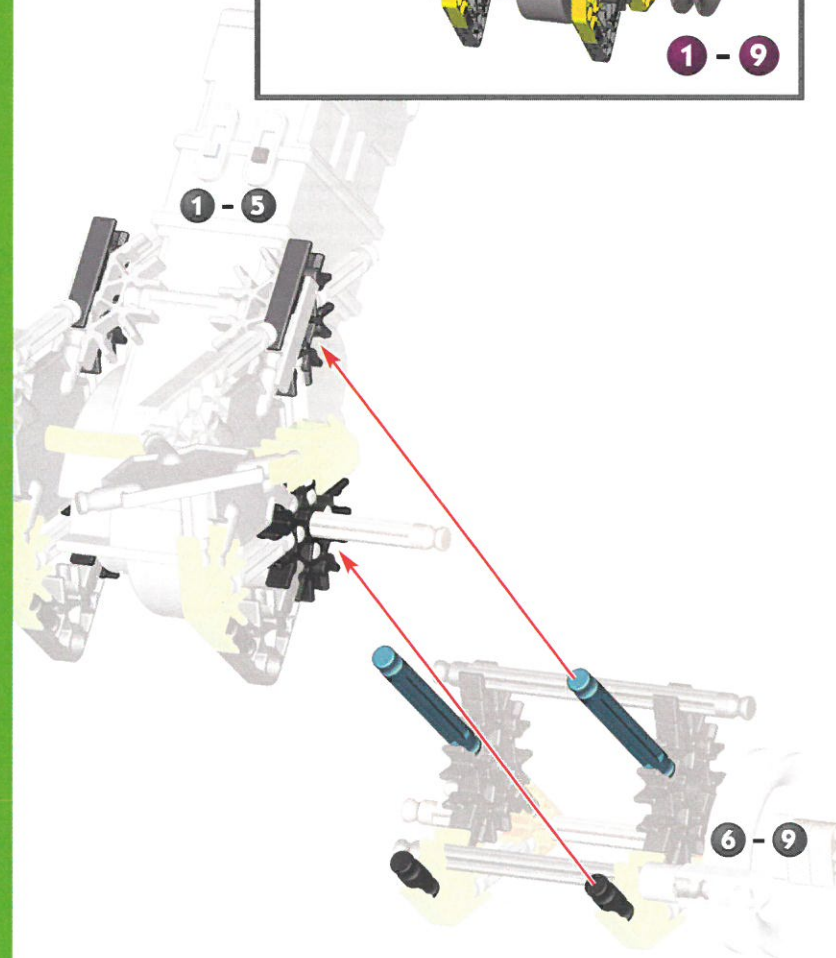
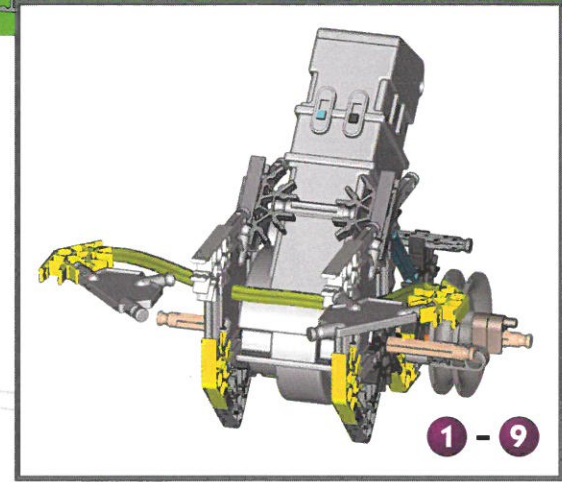
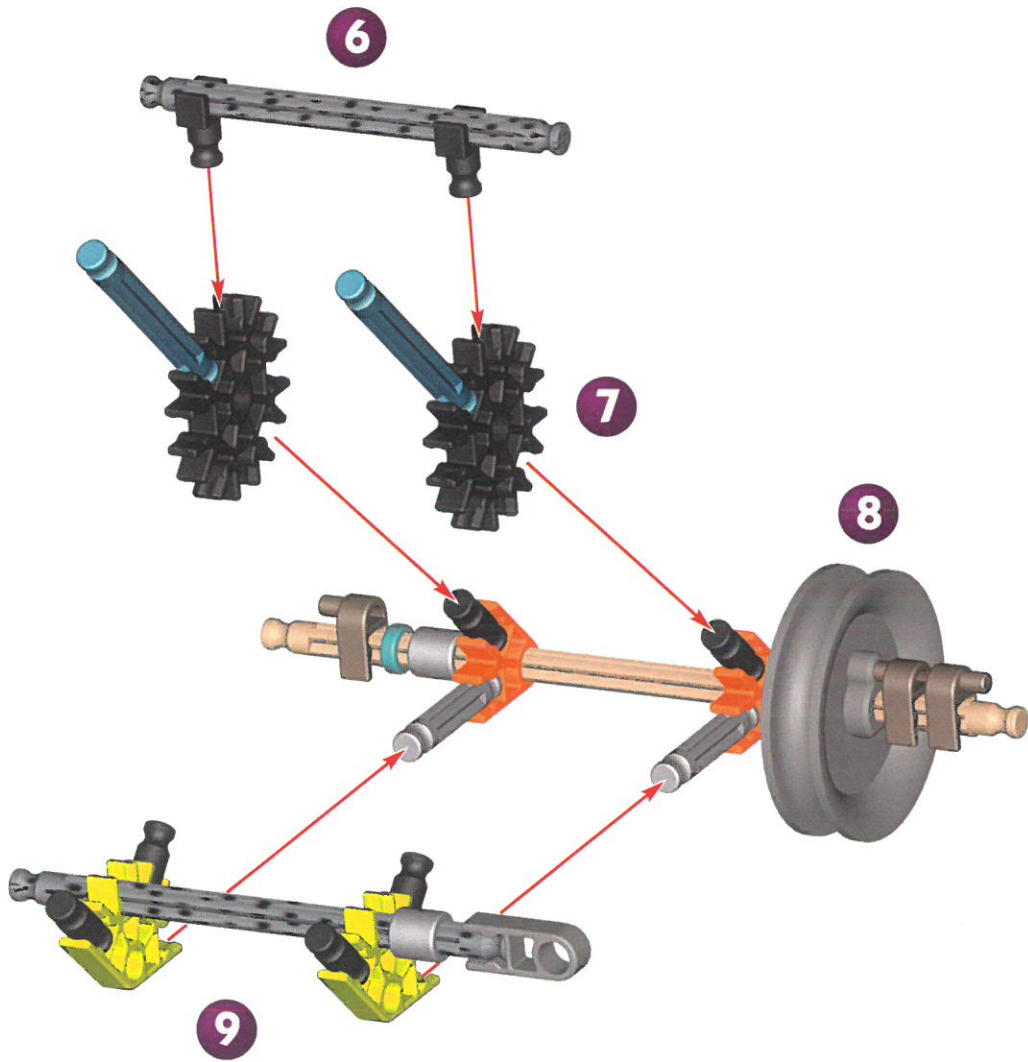

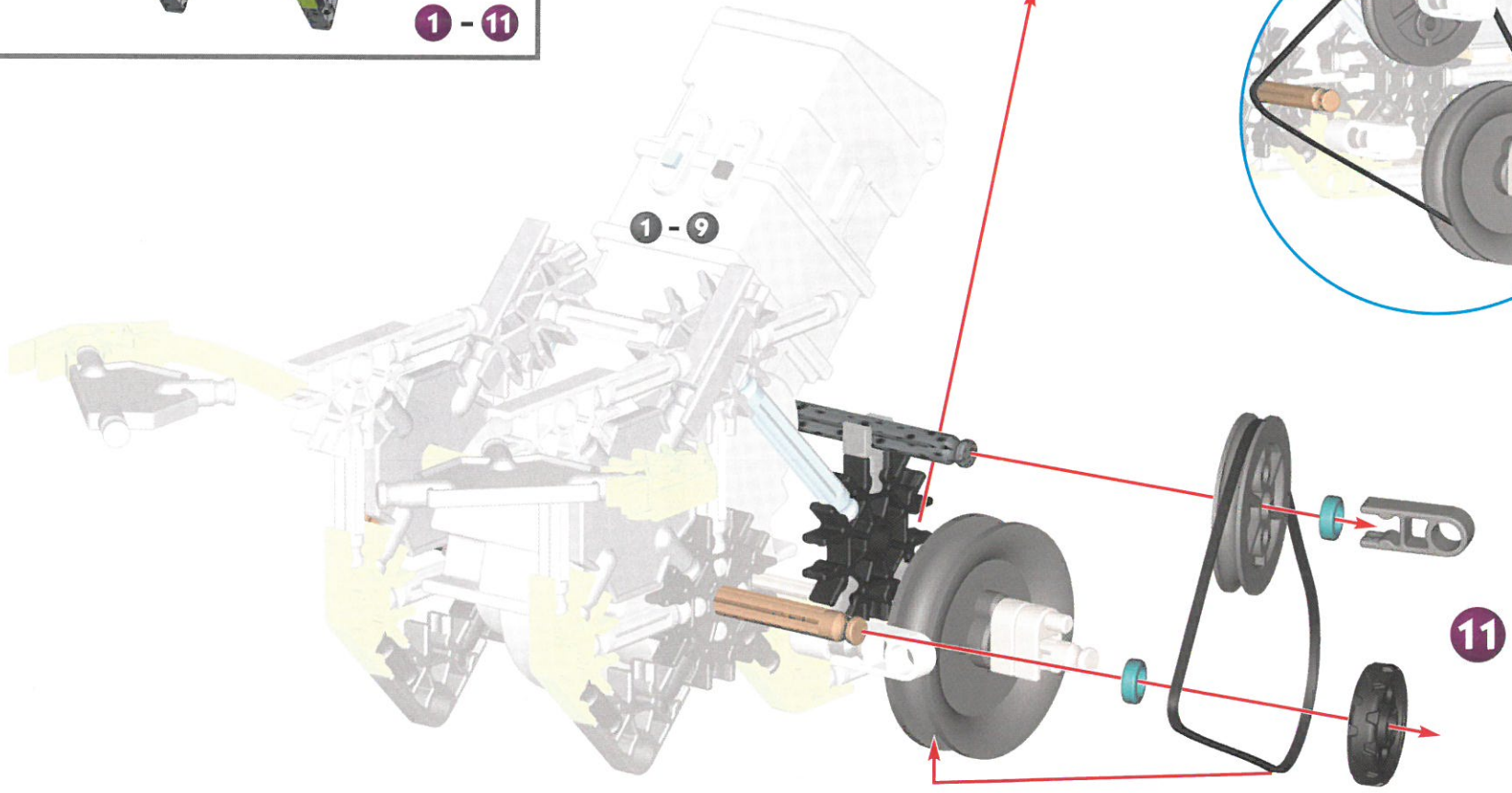
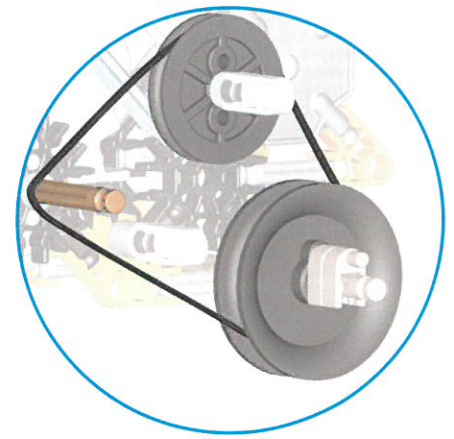
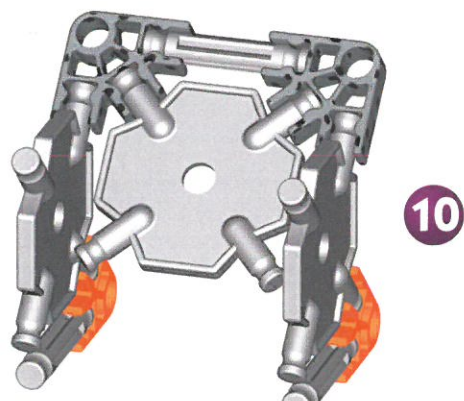
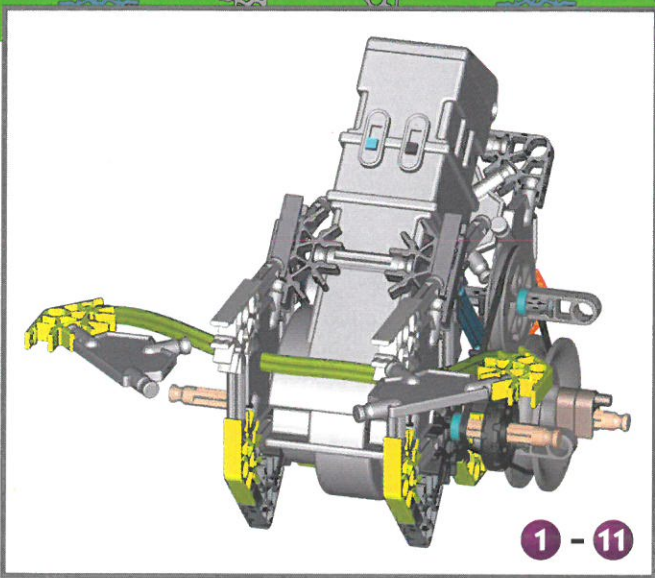

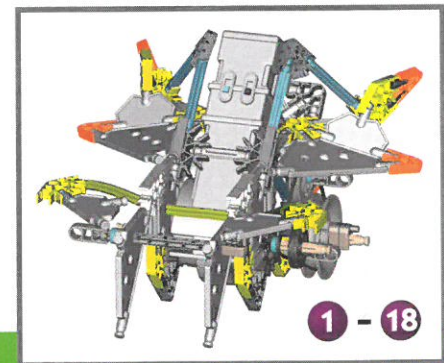
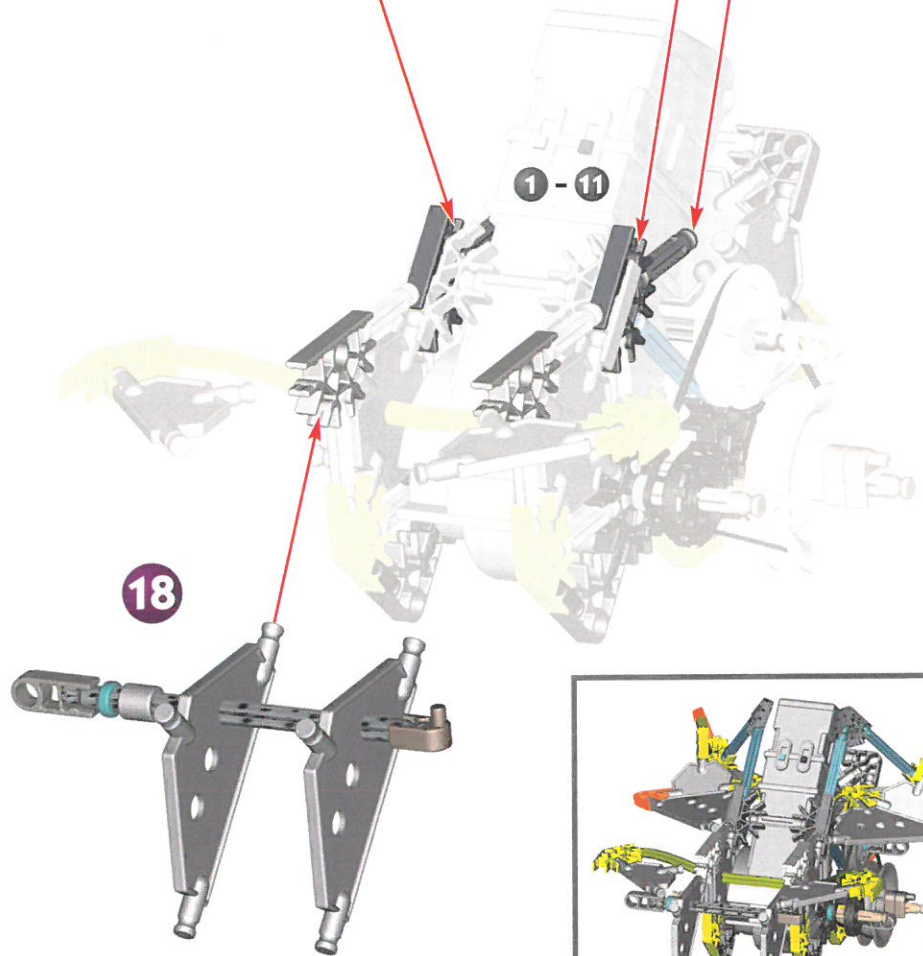
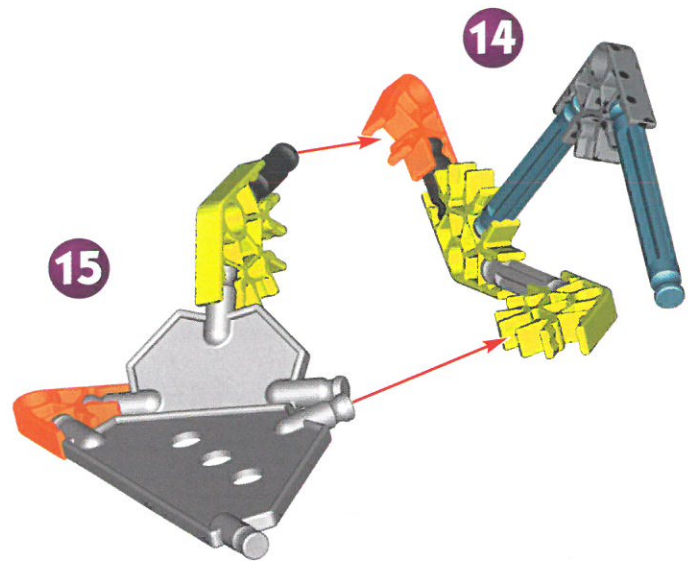
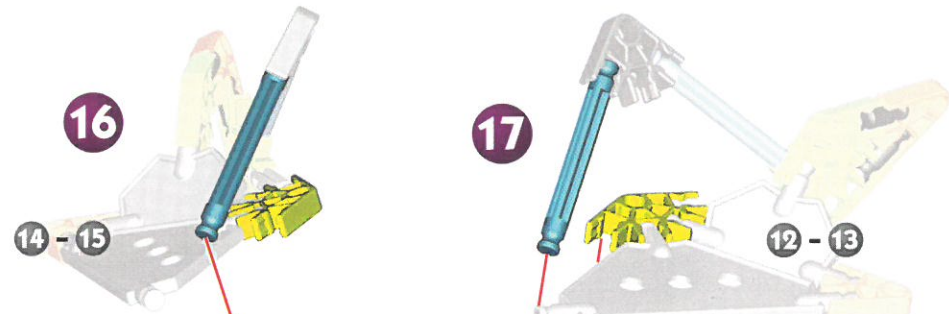
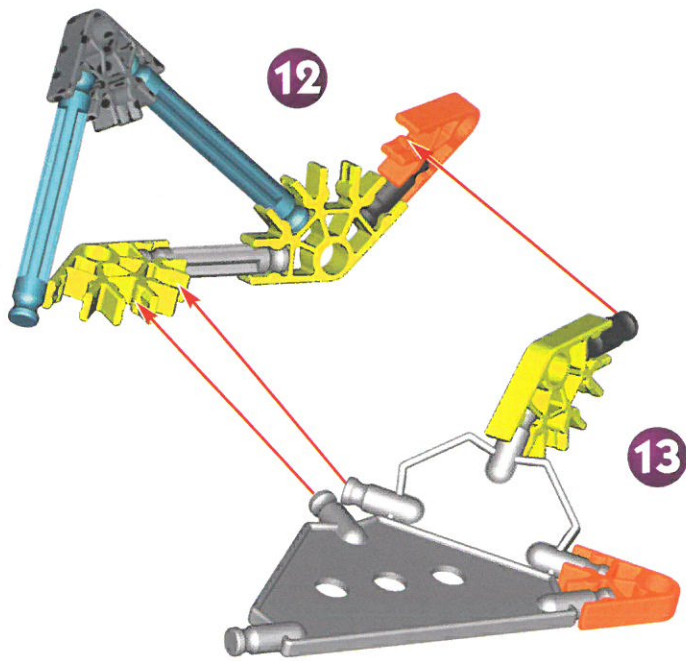

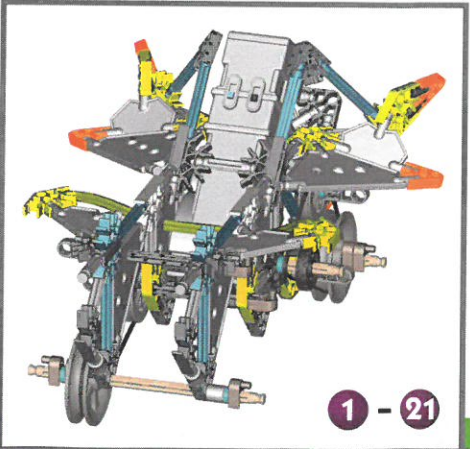
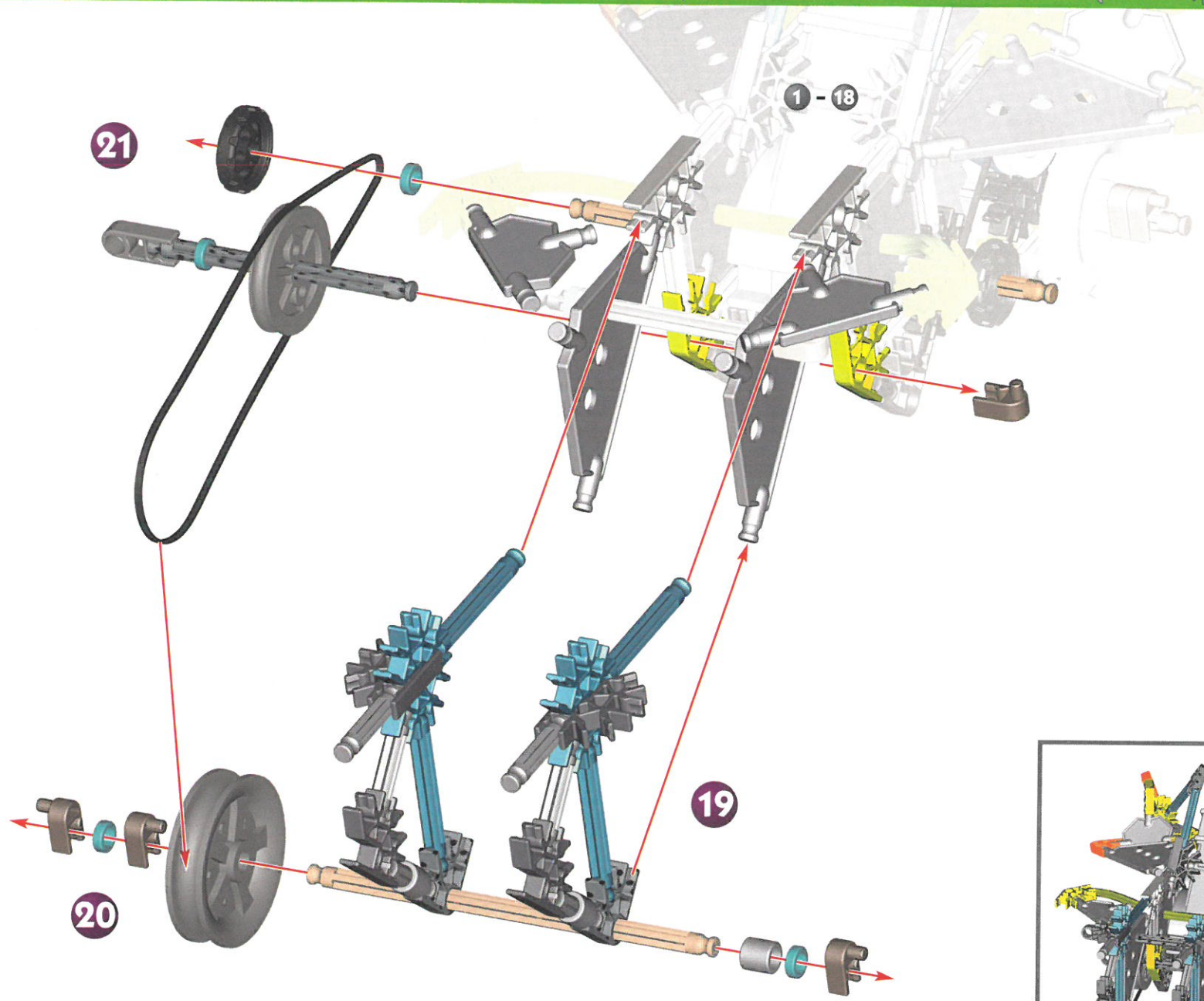

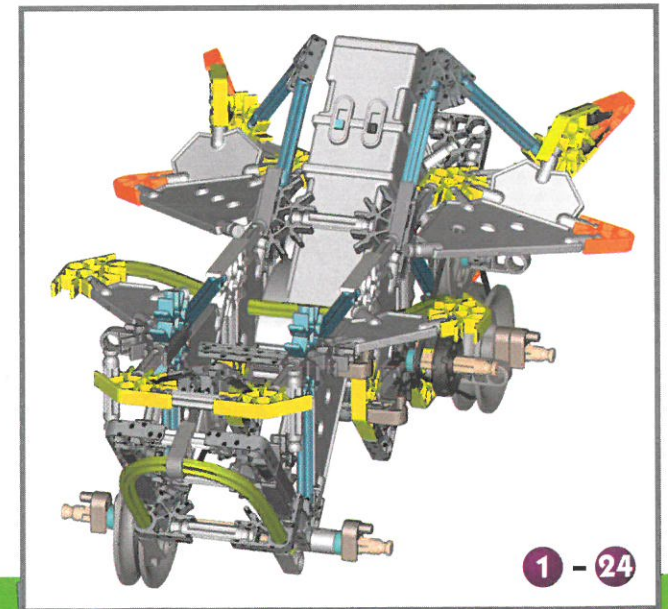
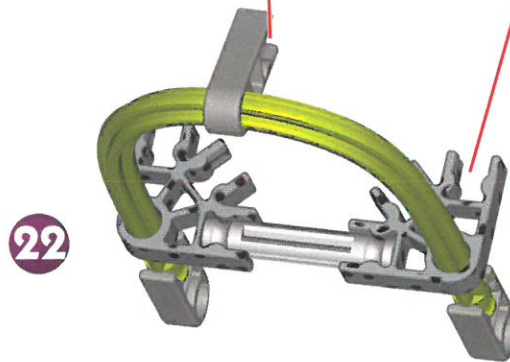
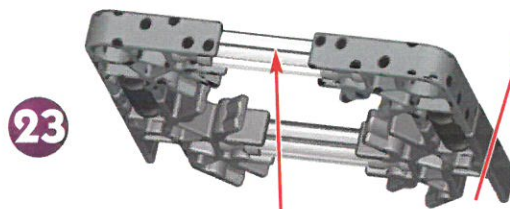
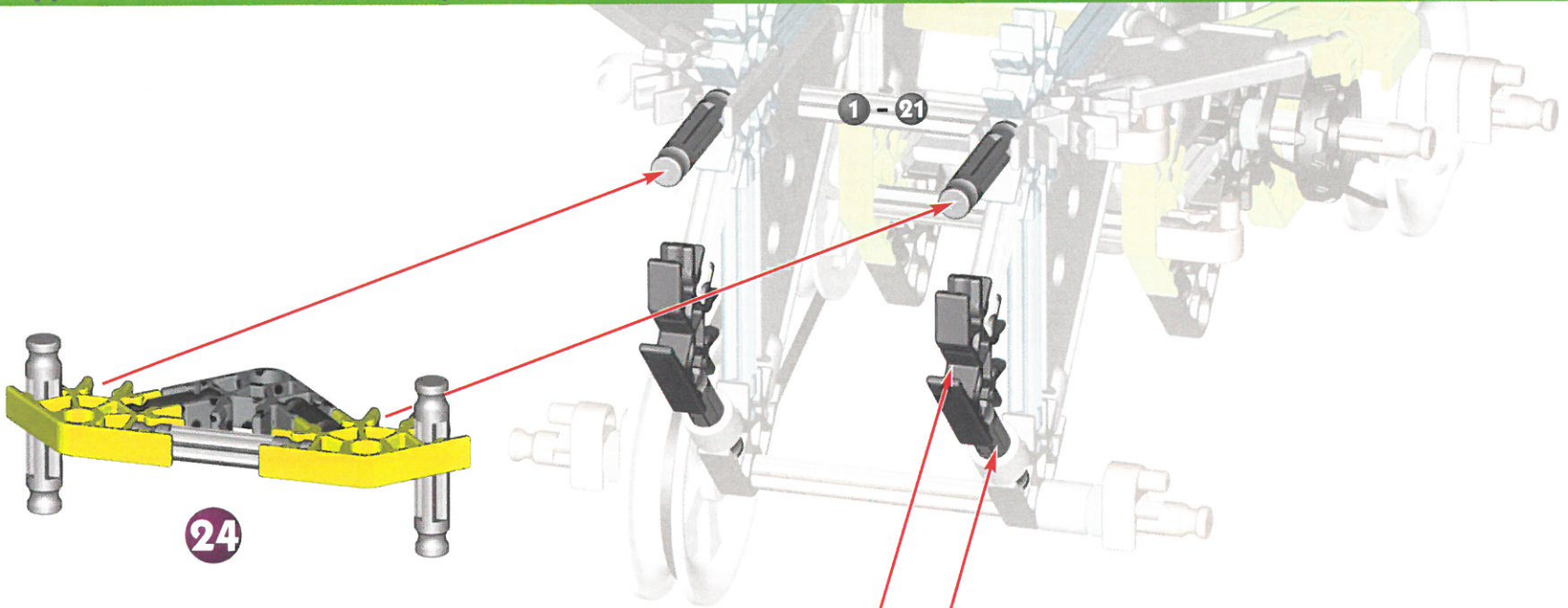

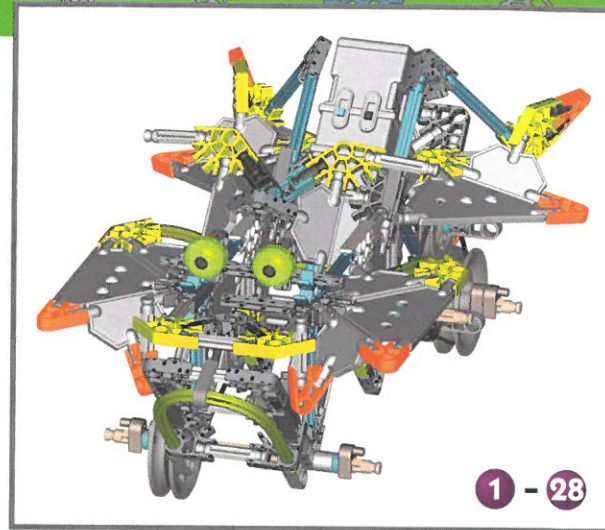
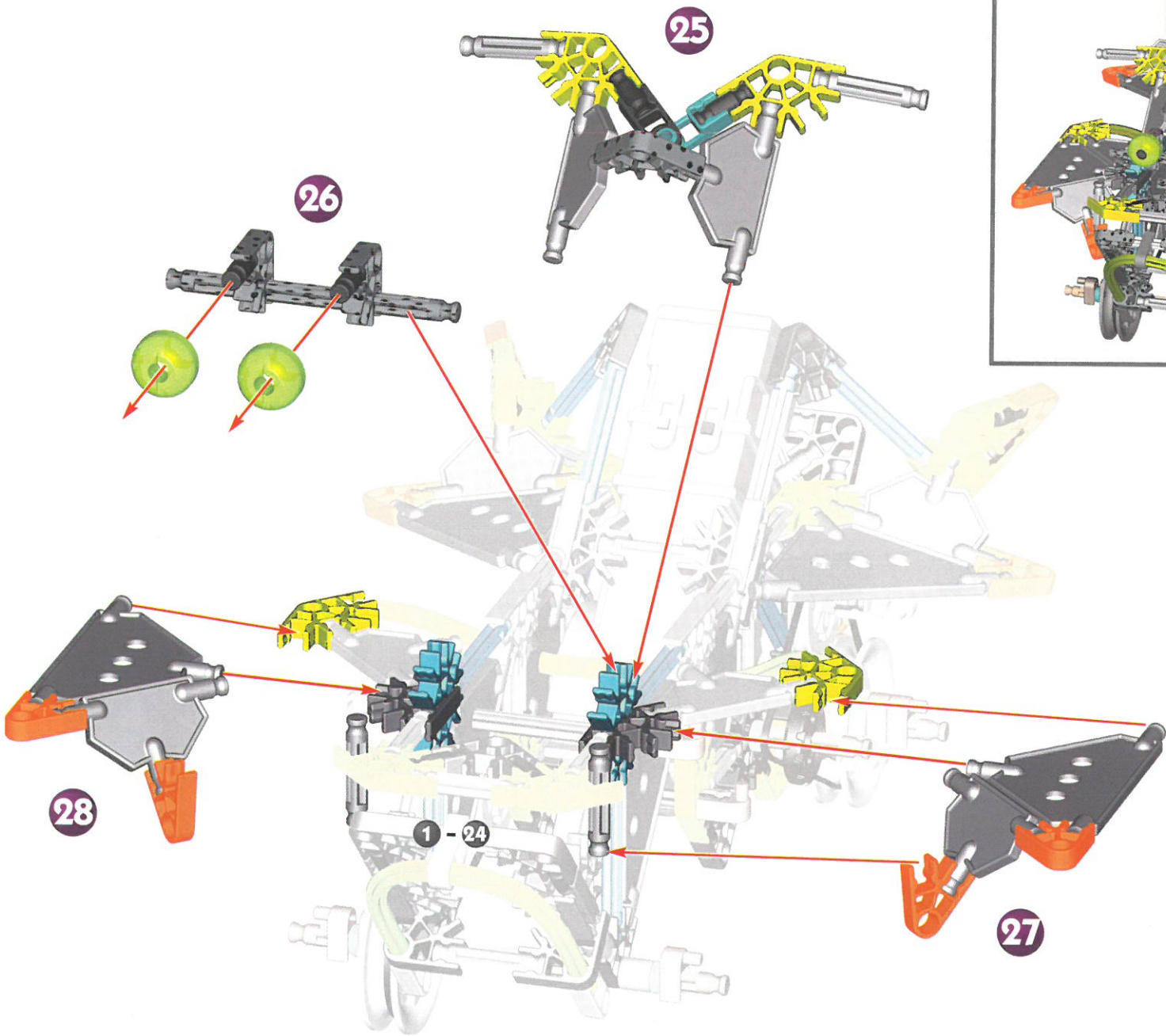

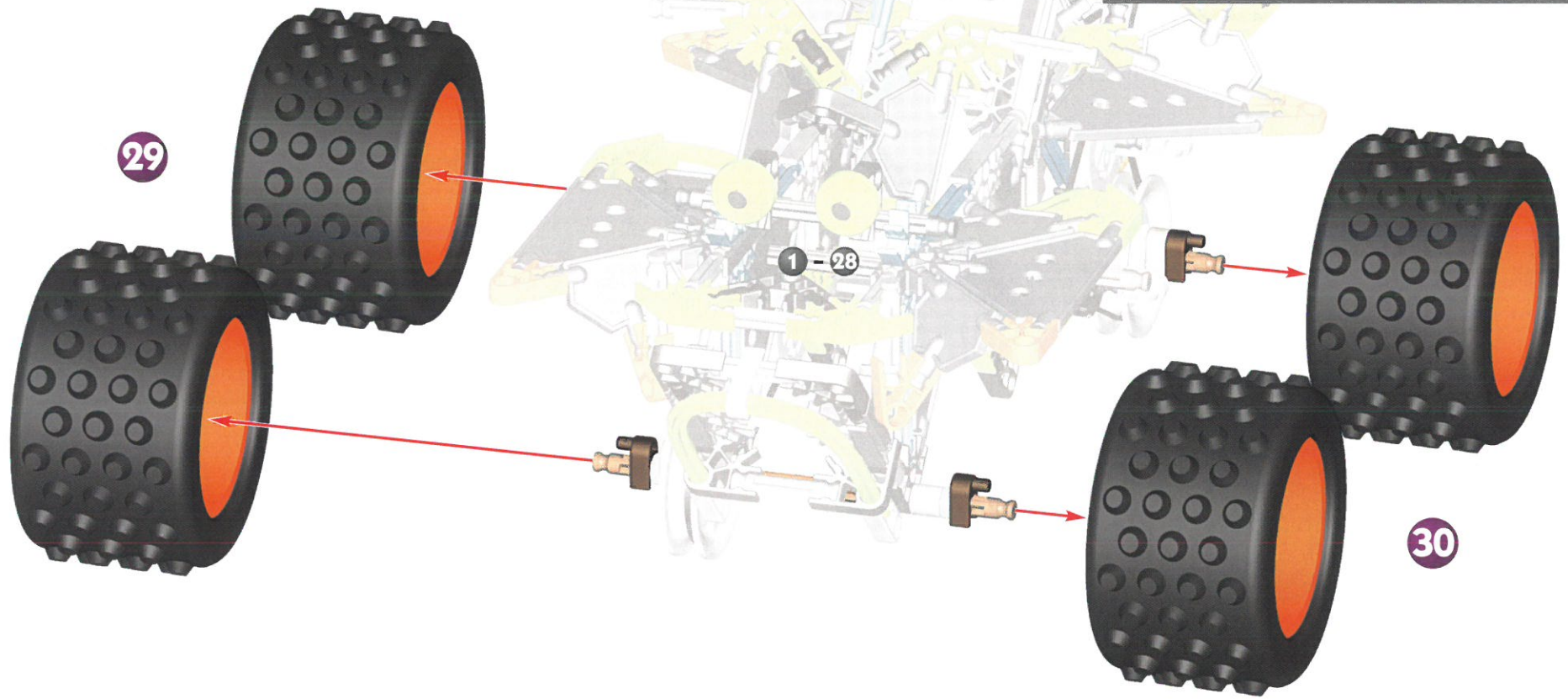
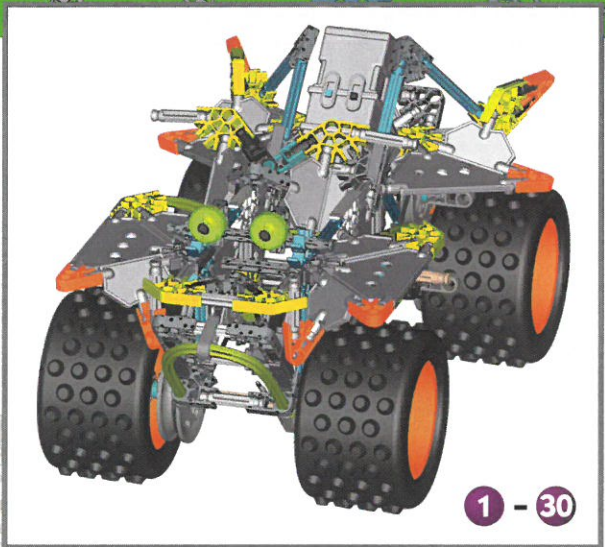
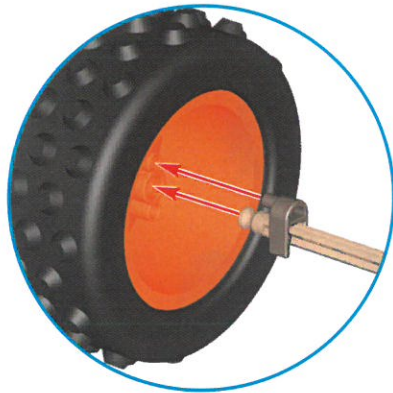

MONSTER TRUCK

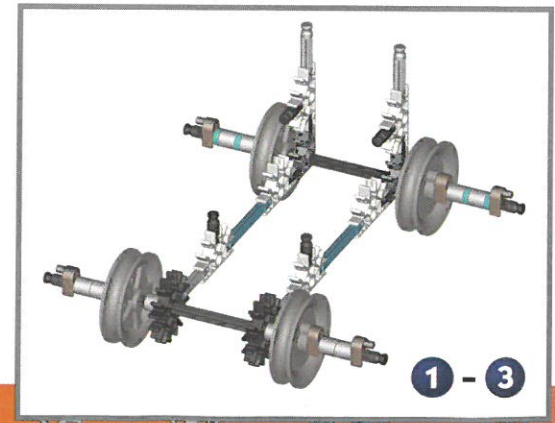
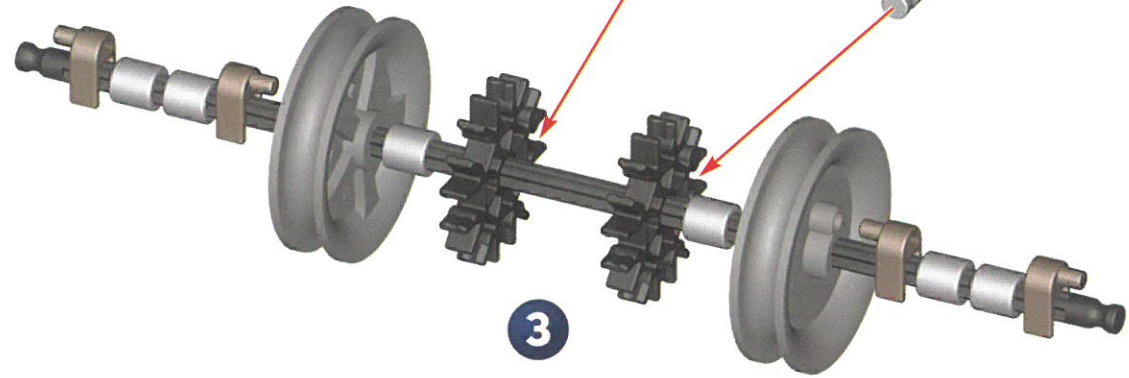
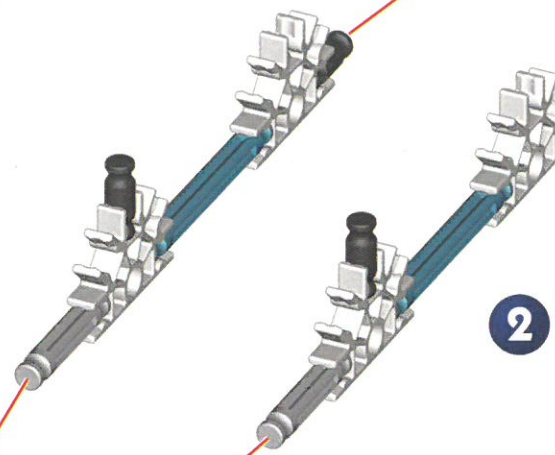
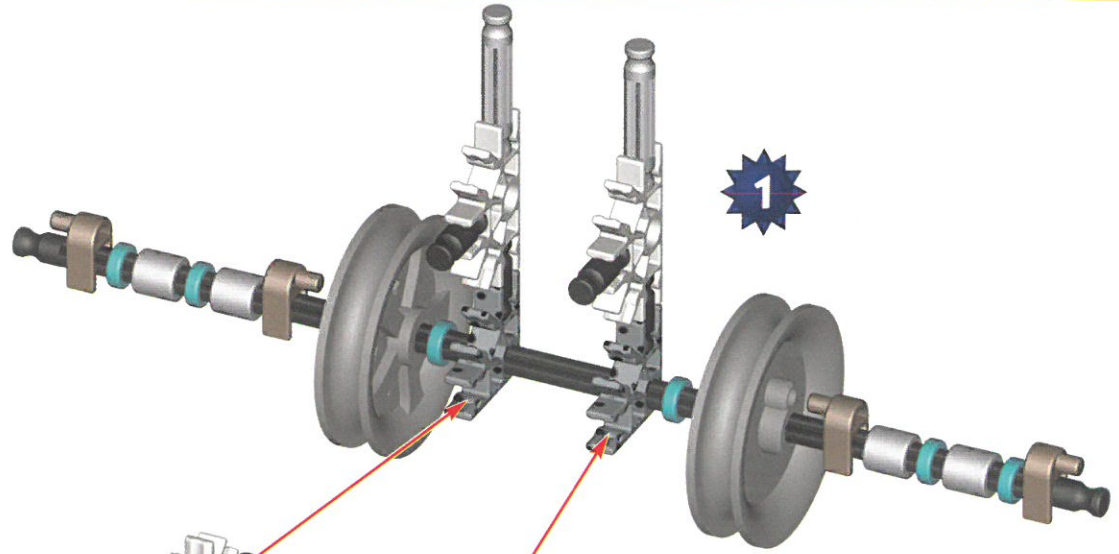
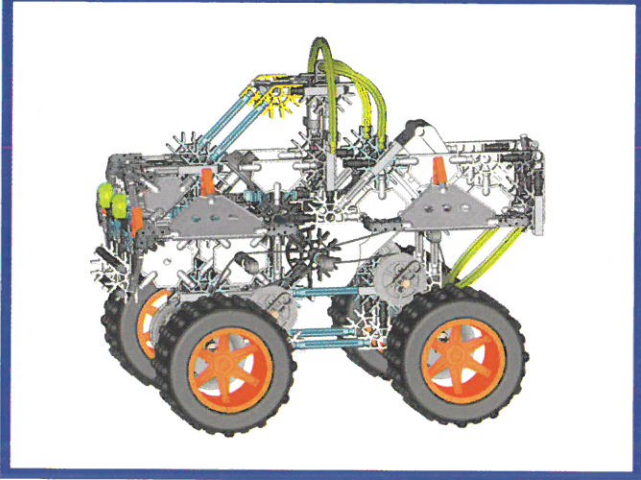

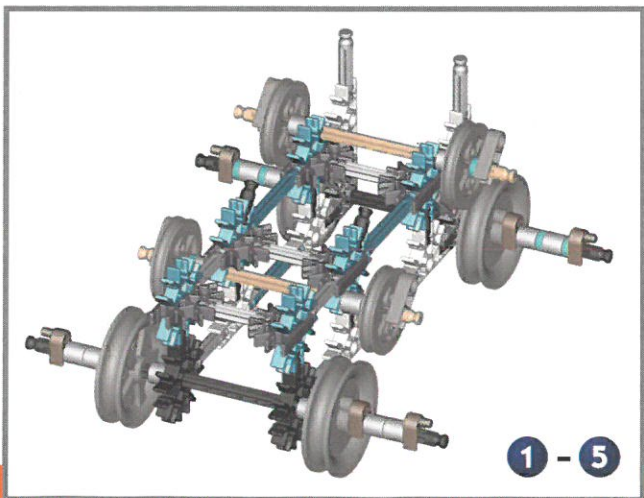
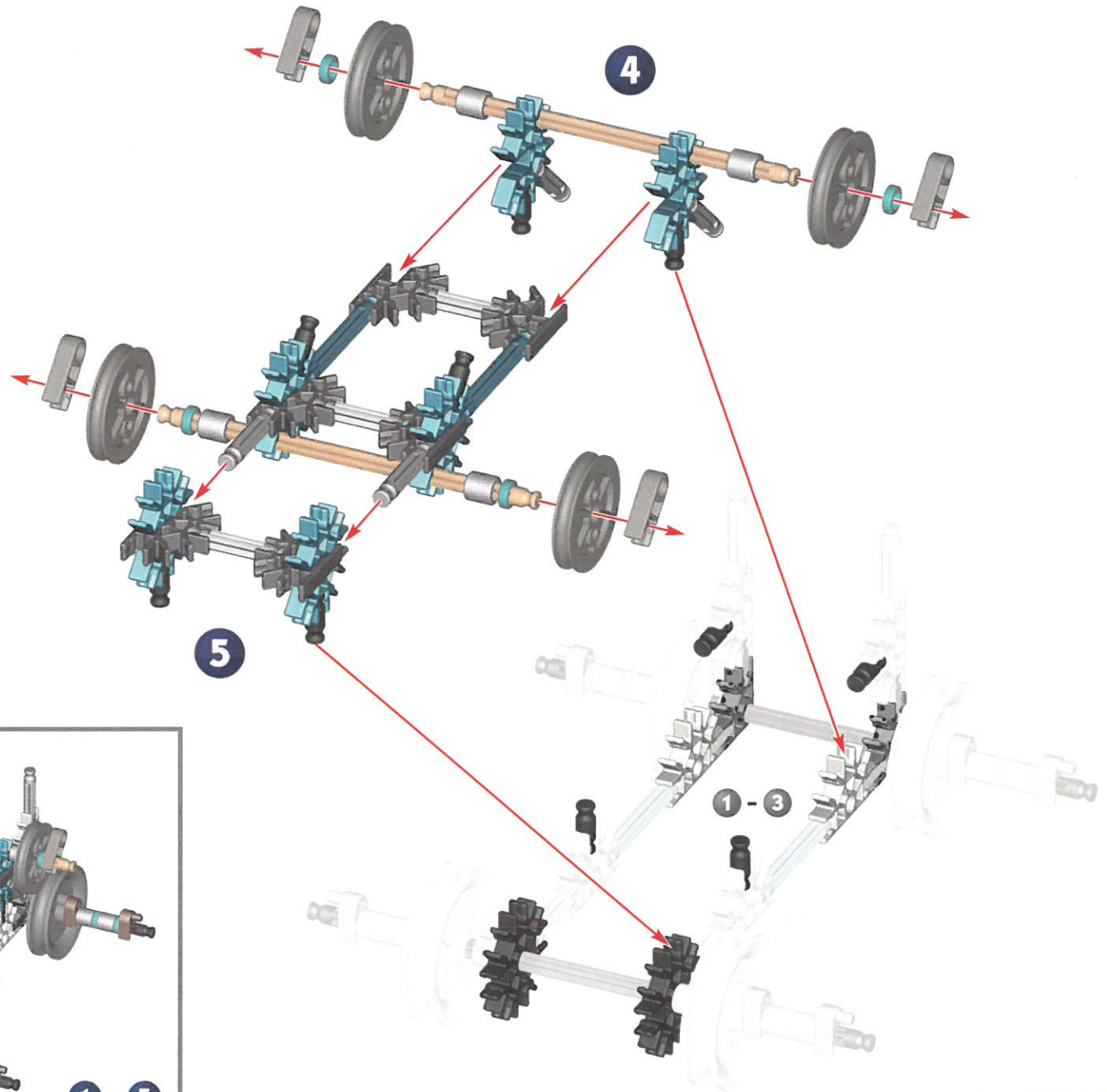

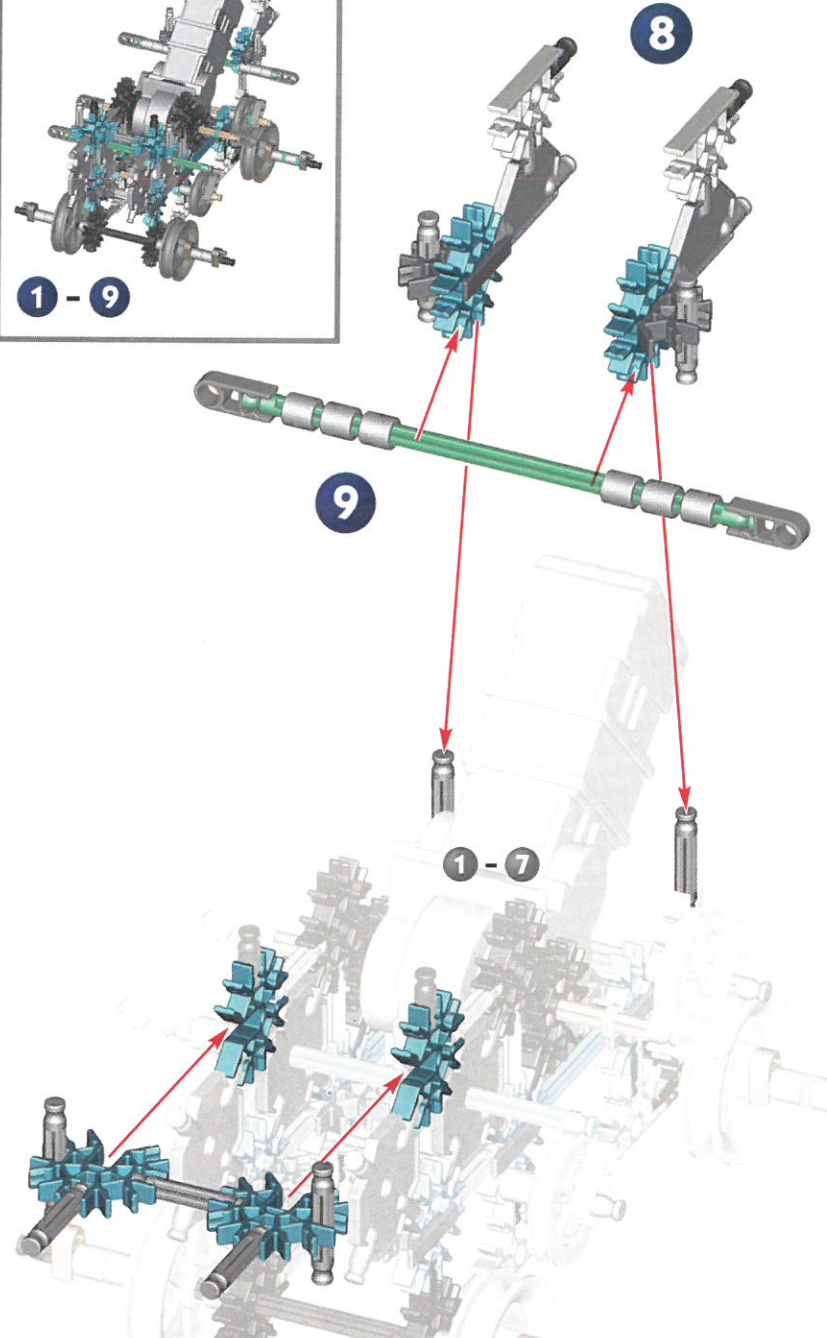
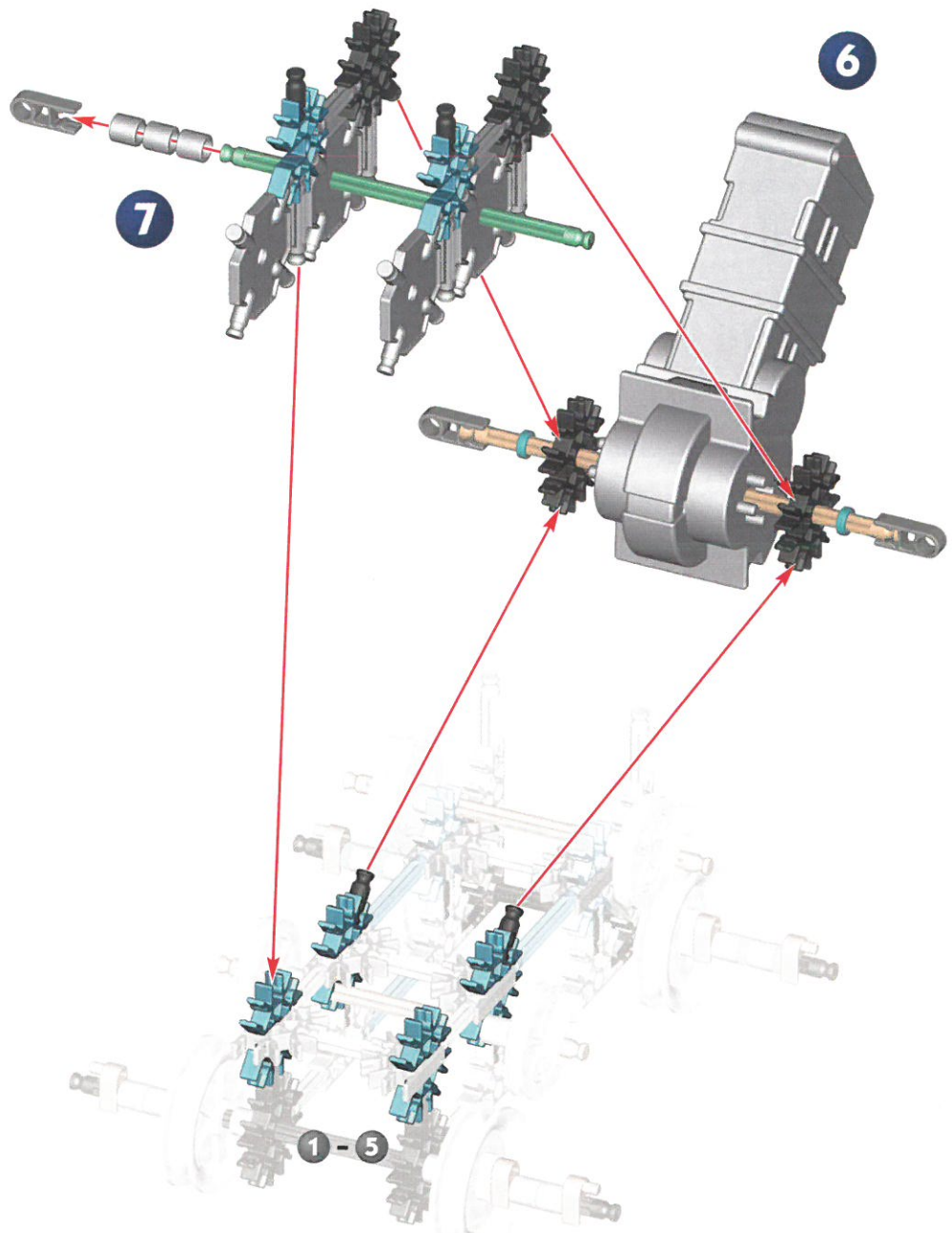

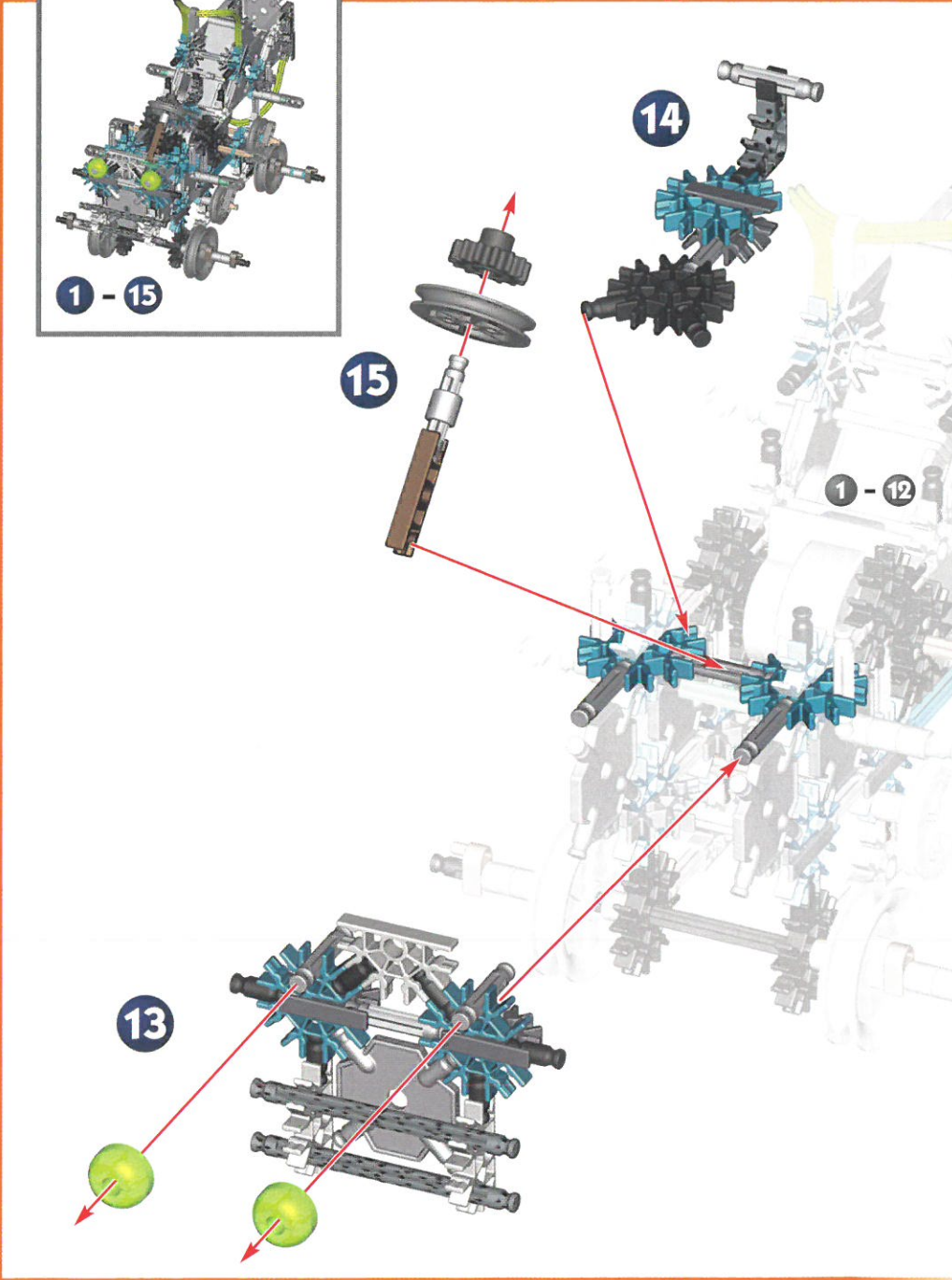

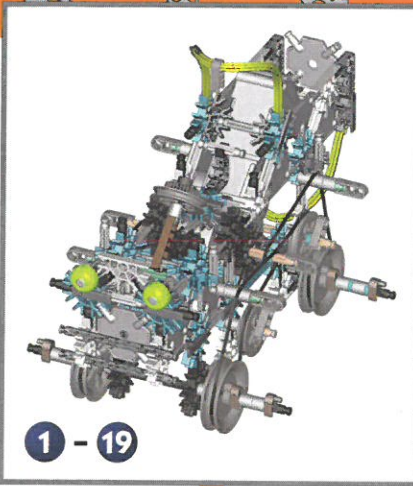
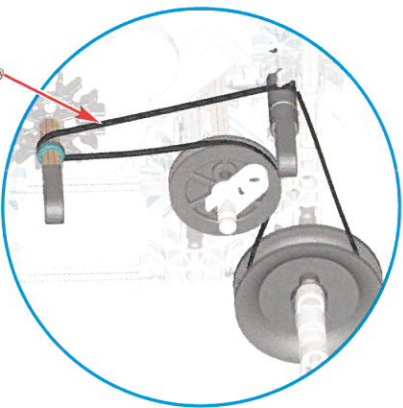

1 - 19

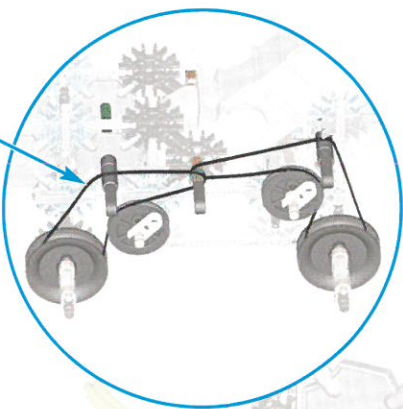

16

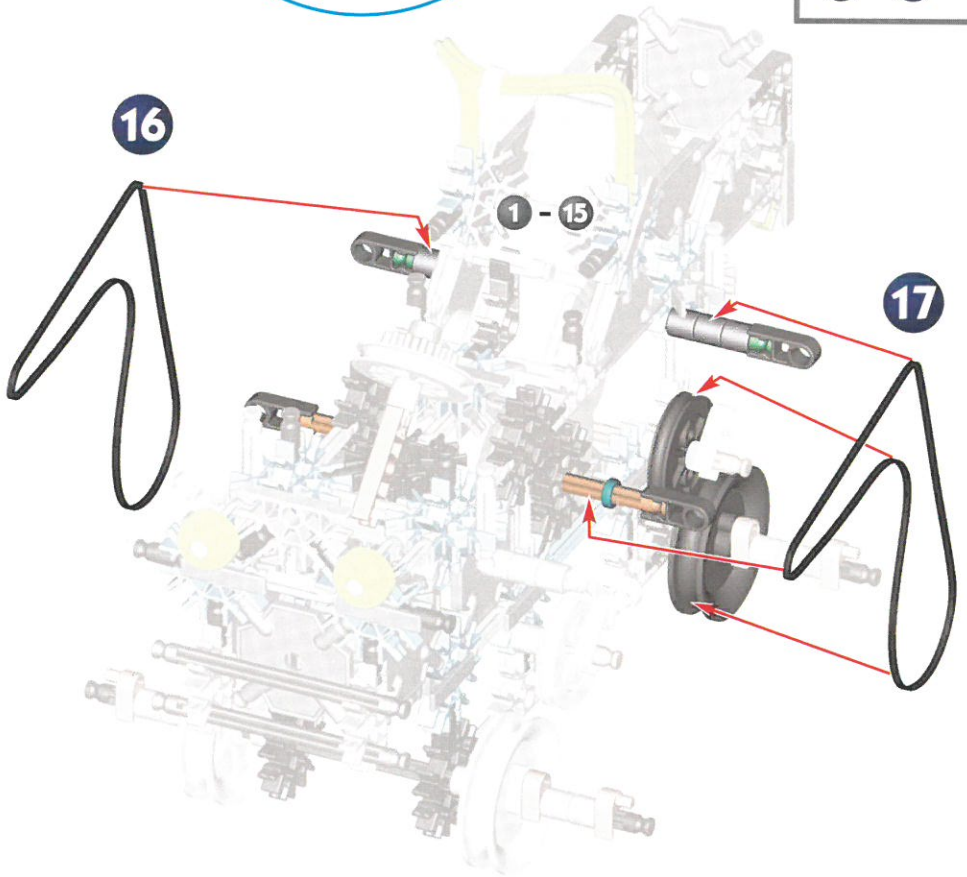

1 - 15

17

19

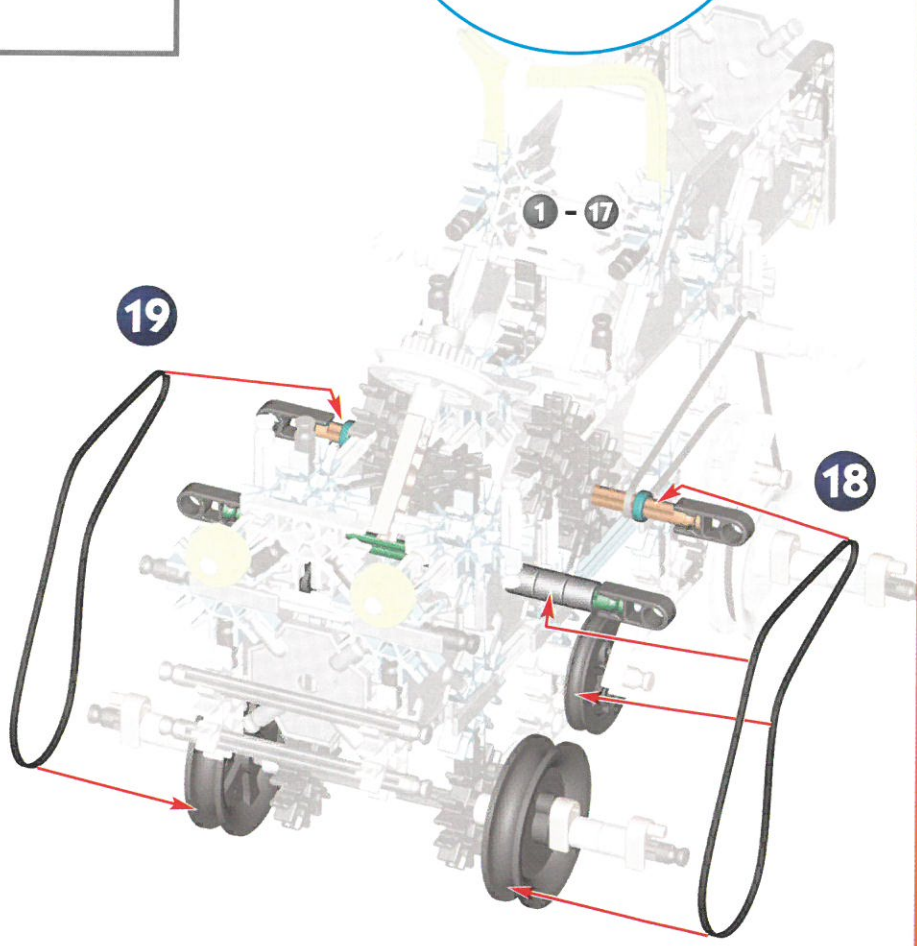

1 - 17

18



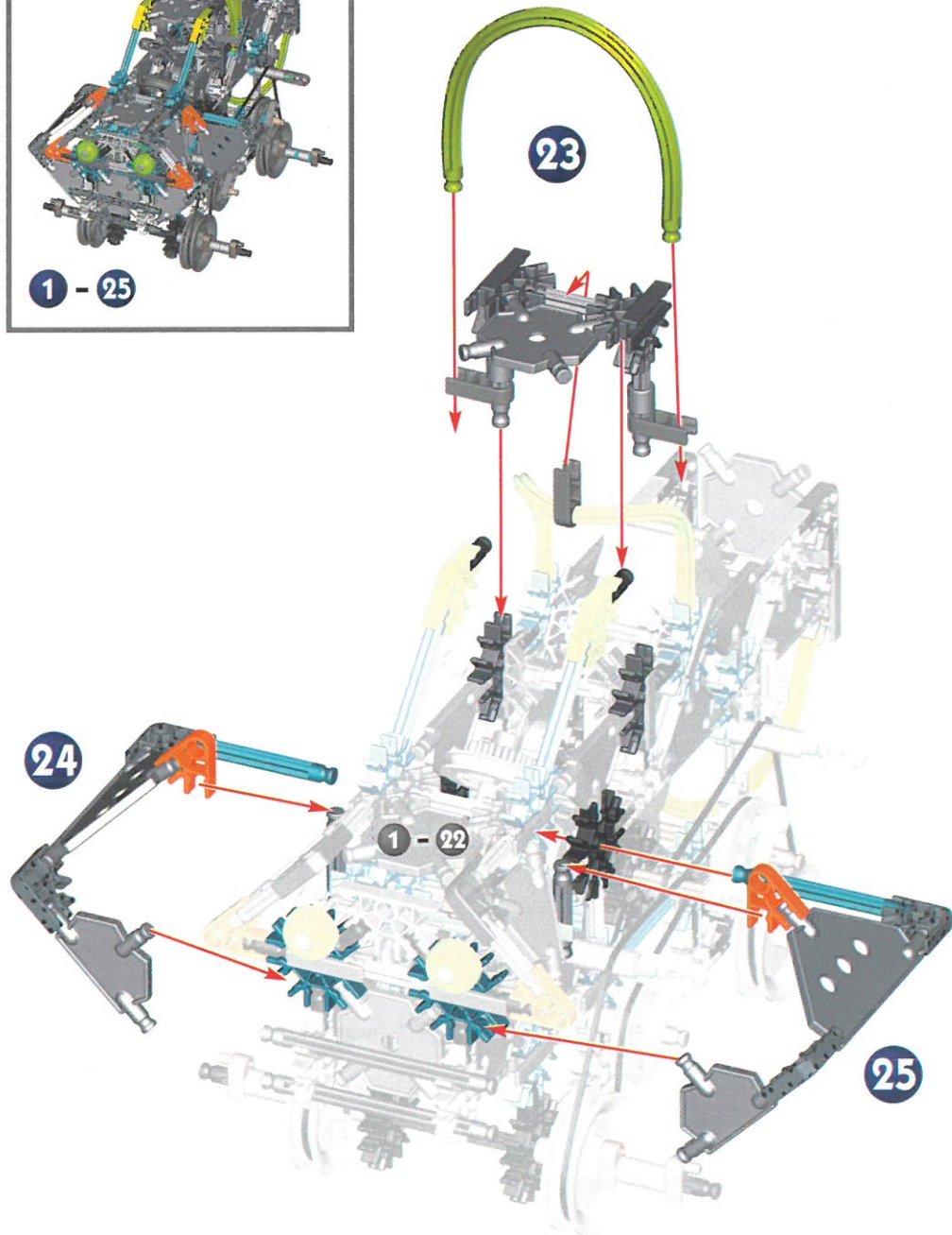
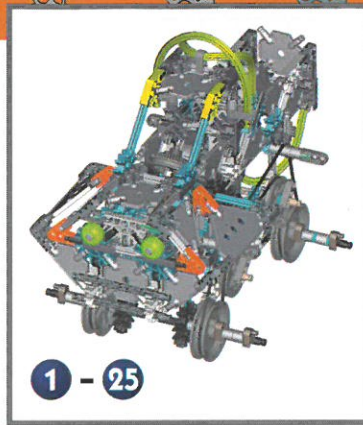
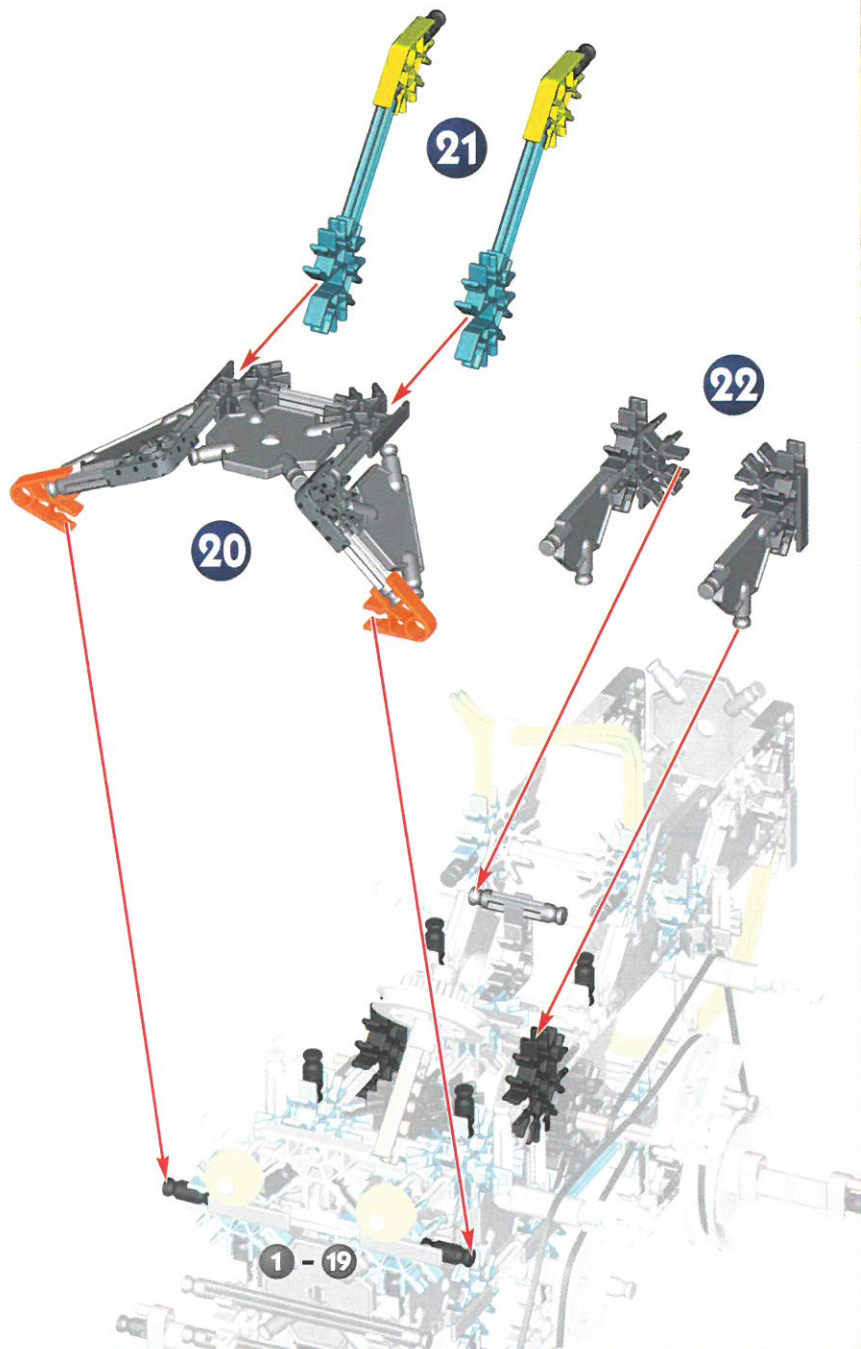

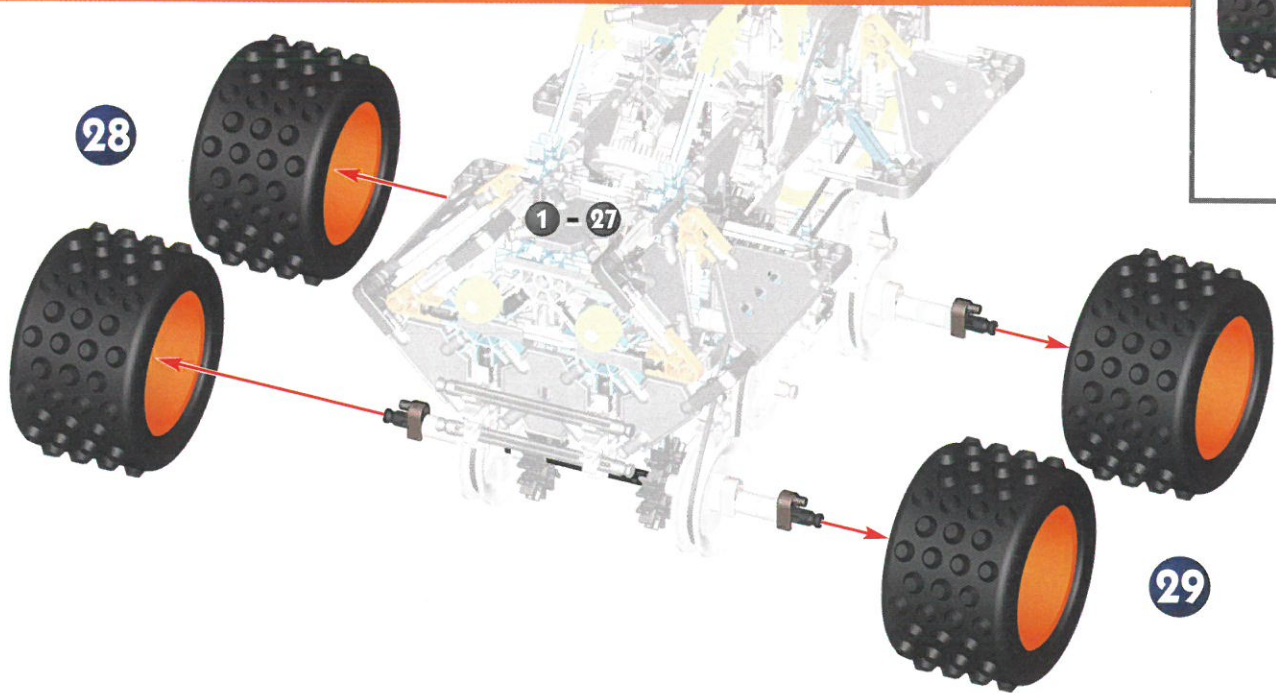
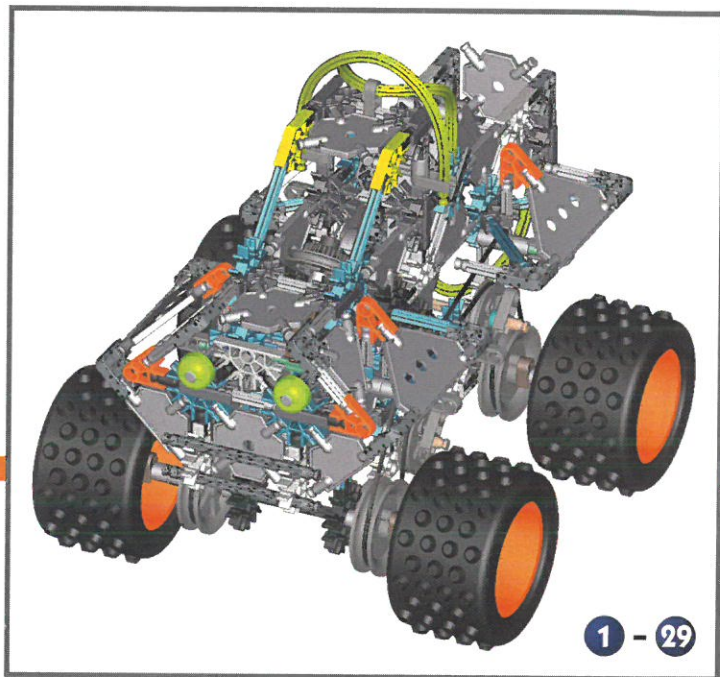
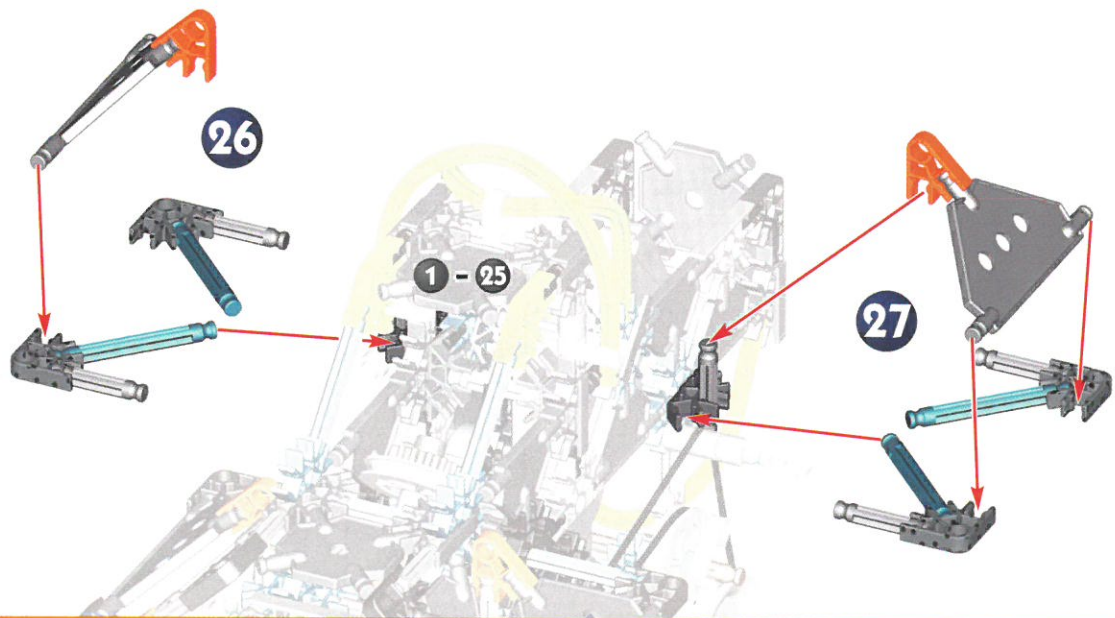

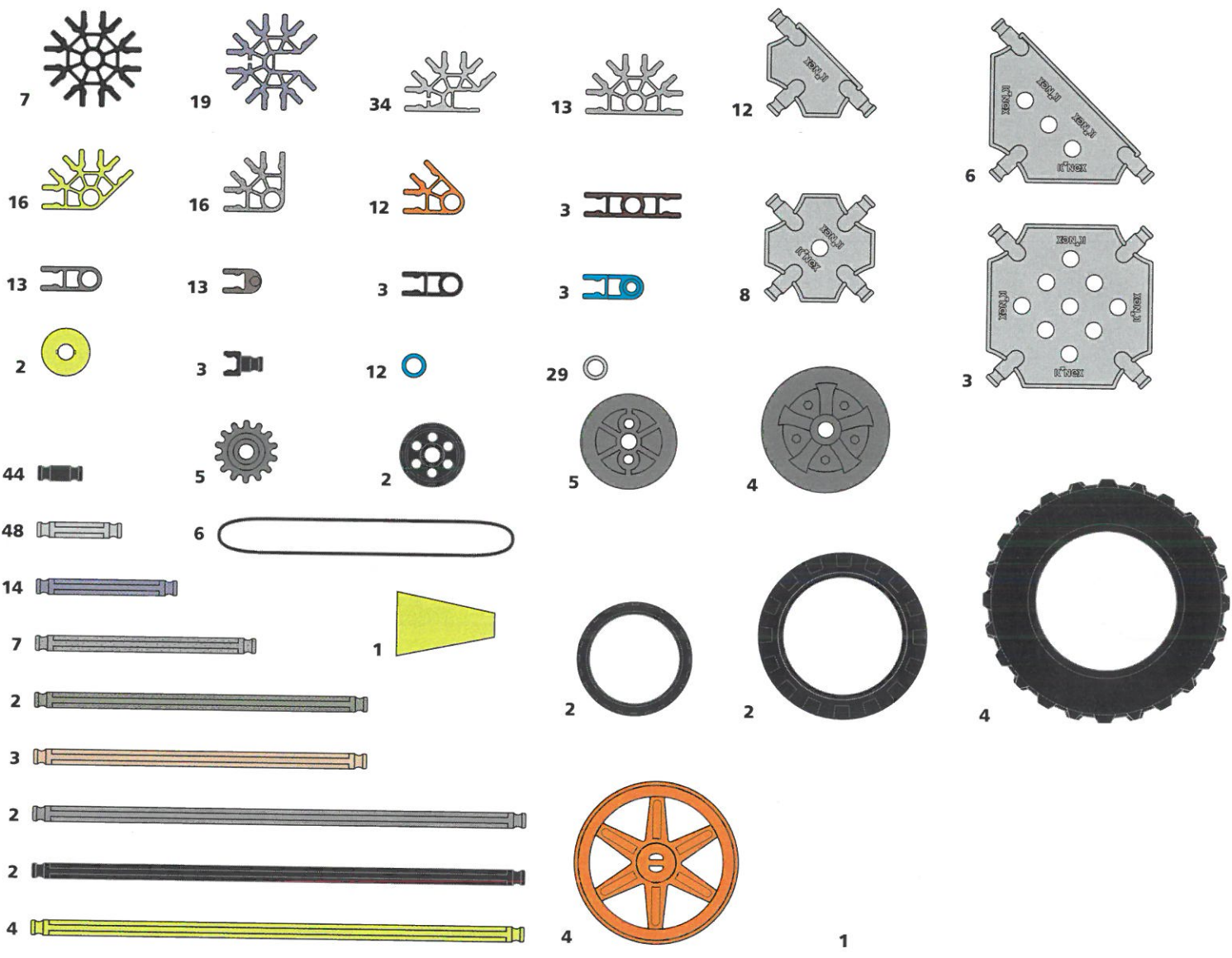

K'NEX[®]

COOL MACHINES

Dragster



Quad



Monster Truck

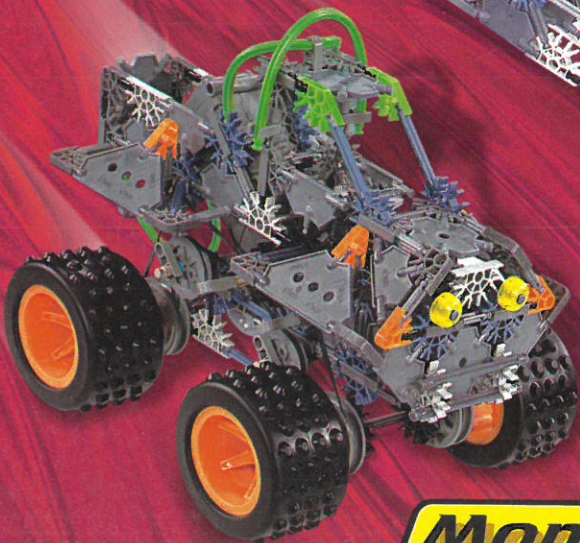

Questions? Call us
at 1-800-KID-KNEX
(USA/Canada only)
www.knex.com

©2000 K'NEX Industries, Inc.
P.O. Box 700
Hatfield, PA 19440-0700

K'NEX is a registered trademark of K'NEX Industries, Inc.
marque déposée de K'NEX Industries, Inc.

Manufactured under U.S. Patents/Fabriqué sous brevets
américains 5,061,219; 5,137,486; 5,199,919; 5,238,438;
5,346,420; 5,350,331; 5,368,514; 5,421,762; 5,423,707;
5,427,559; 5,518,435; D383,509; D388,475; D389,203;
D391,843; D391,921; D392,555. Other U.S. and foreign
patents pending./Autres brevets américains et étrangers
en instance.

Colors and product may vary.
Set contains one dual speed motor.

Le produit et les couleurs peuvent
varier. Aucun moteur n'est contenu
dans ce kit.

El producto y los colores pueden
variar. Este juego no contiene
ningún motor.

Conforms to the Requirements of ASTM Standard Consumer
Safety Specification on Toy Safety, F963-96a./Conforme
aux spécifications de sécurité du consommateur sur la
sécurité des jouets de la norme ASTM F963-96a.

94296-V1-4/00