

K'NEX®

Building Worlds Kids Love®

CLOCK WORK
MONTAÑA RUSA
SET DE CONSTRUCCIÓN

CLOCK WORK
MONTANHA RUSSA
SET DE CONSTRUÇÃO

CLOCK WORK
ROLLER COASTER
BUILDING SET

HORLOGIE
MONTAGNES RUSSES
JEU DE CONSTRUCTION



MOTOR
MOTEUR

2 x



• NO INCLUIDAS
• NÃO INCLUIDAS
• NOT INCLUDED
• PAS INCLUS

Mantener esta información para futuras referencias

Información importante para Padres y Niños



ADVERTENCIA: No conveniente para niños menores de 3 años. Piezas pequeñas. Peligro de atragantamiento.

¡ATENCIÓN! Mantener las manos, la cara, el pelo y la ropa fuera del alcance de las partes móviles.

¡ATENCIÓN! Mantener la estructura montada encima de una superficie plana y rígida.

PRECAUCIÓN: Si el cabello del niño entra en contacto con las partes en movimiento del juguete, puede quedar enredado.

- No obstruyas la pista con objetos o cualquier parte de tu cuerpo.
- Compartan la experiencia K'NEX con su niño y hagan que la construcción con K'NEX sea una divertida aventura de toda la familia.
- Dedicar tiempo a disfrutar el proceso de construcción. ¡No te apresures!
- Mientras construyes, trata de colocar tu modelo en la misma dirección que se muestra en las instrucciones.
- El producto y los colores pueden variar.

Para actualizar las instrucciones

visita KNEX.COM

Información de la Batería

Cómo insertar y cambiar las baterías

Use un destornillador pequeño.

¡ATENCIÓN! Antes de empezar a montar la estructura, debe insertar las baterías.

Recomendamos efectuar el cambio de baterías por un adulto.



- Inserte las 2 baterías (LR6-1,5 V) no incluidas, dentro del compartimiento, respetando siempre la polaridad. Tal como se indica en el dibujo.
- No mezcle diferentes tipos de baterías, o nuevas y usadas.
- No mezcle baterías alcalinas, standard (carbón-zinc) o recargables (níquel-cadmio).
- Usar solamente las baterías recomendadas. Recomendamos usar baterías alcalinas.
- Retirar las baterías recargables para su carga. Recargar las baterías bajo la supervisión de un adulto. No recargar las baterías no recargables.
- Quitar las baterías usadas del juguete. Y retirarlas si no va a jugar durante un largo periodo de tiempo.
- No cortocircuitar los terminales de alimentación.
- Mantener limpio de polvo y suciedad, y no sumergir o usar con agua.
- No tirar las baterías al fuego, podrían explotar.
- No introducir ninguna varilla inferior a la medida recomendada, podría dañar el motor.



El contenedor de basura indica que este producto no puede desecharse con la basura doméstica debido a la presencia de sustancias peligrosas. Con el fin de impedir posibles daños medioambientales deseche éste producto de una forma segura en los puntos de reciclaje de su ciudad.

Mantener esta informação importante para referencia futura

Coisas importantes para os Pais e os Miúdos



¡ATENÇÃO! Não recomendado para crianças menores de 3 anos. Pequenas partes. Risco de asfixia.

¡ATENÇÃO! Mantém o cabelo, os dedos, a cara e a roupa afastados de todas as peças móveis.

¡ATENÇÃO! O cabelo da criança pode ficar emaranhado se entrar em contacto com as peças móveis do brinquedo.

¡ATENÇÃO! Mantém a estrutura colocado sobre uma superfície plana e dura.

- Não obstruir a trilha com objetos ou qualquer parte de seu corpo.
- Compartilhe da experiência K'NEX com os miúdos e faça com que o processo de construção com K'NEX se torne numa aventura entre família.
- Não te precipites para assim poderes desfrutar do processo de construção. Não o faça à pressa!
- Tenta fazer com que o teu modelo esteja virado exactamente na mesma direcção indicada nas instruções.
- Tanto o produto como as respectivas cores podem variar.

Entre em K'NEX.COM para ver actualizações e instruções

Informações sobre as pilhas

Como introduzir e remover pilhas

Usar uma chave de fenda pequena.

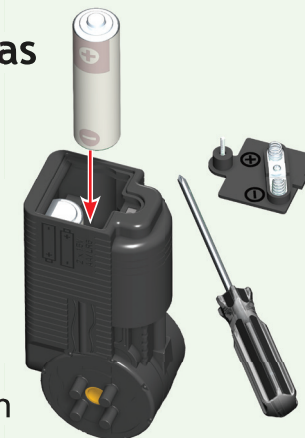

¡ATENÇÃO! Instale pilhas antes modelos de construção. Recomendamos a substituição da pilha por um adulto.

- Introduzir 2 pilhas (LR6-1,5 V) não incluídas, no compartimento de pilhas com a polaridade correta. Como está mostrado na figura.
- Não misture tipos diferentes de pilhas. Não combine pilhas usadas com pilhas novas.
- Não misture pilhas alcalinas, padrão (carbono-zinco) ou pilhas recarregáveis (níquel-cádmio).
- Apenas pilhas do mesmo tipo ou equivalentes ao tipo recomendado.
- Retire sempre as pilhas fracasso u gastas do produto; não provoque um curto-circuito nos terminais de alimentação.
- Retire todas as pilhas do brinquedo se não tencionar usá-lo durante um longo período de tempo.
- Recomenda se o uso de pilhas alcalinas.
- Não se recomenda o uso de pilhas recarregáveis. Retire as pilhas recarregáveis do brinquedo antes de as carregar; estas pilhas devem ser carregadas apenas sob vigilância de adultos.
- As pilhas não recarregáveis não devem ser carregadas.
- Mantenha os componentes livres de poeiras; não mergulhe em agua nem use agua.
- Não elimine as pilhas queimando-as; estas podem apresentar fugas ou explodir causando lesões.
- Não coloque varetas de tamaño inferior em nenhuma abertura do motor; as varetas causarão danos no motor e não podem ser removidas.



O caixote do lixo indica que este produto não pode ser descartado junto com o lixo doméstico devido à presença de substâncias perigosas. Para proteger a saúde humana e o meio ambiente verifique a sua autoridade local para reciclagem conselho e instalações.

Keep this important information for future reference

Important Stuff for Parents and Kids



WARNING: CHOKING HAZARD - Small parts. Not for children under 3 years.

CAUTION: Keep hands, face, hair and clothing away from all moving parts.

CAUTION: Be careful not to tip the model over. Model should be placed on a flat and hard surface.

- Do not obstruct track with objects or any part of your body.
- Share the K'NEX experience with your child and make building with K'NEX a family fun adventure.
- Take your time to enjoy the building process. Don't rush!
- While you're building make sure you face your model in the same direction as the pictures show in the instructions.
- Product and colors may vary.

Go to KNEX.COM for instruction updates

Battery Information

How to Insert and Remove Batteries

Use a small Phillips head screwdriver to loosen the screw. Insert 2 fresh AA batteries** (LR6) into the compartment with the correct polarity (+/-) as shown here.

Install batteries before building models.

** Not included

CAUTION: To Avoid Battery Leakage

- Insert batteries with correct polarity (+/-) as shown.
- Do not mix different types of batteries.
- Do not mix alkaline, standard (carbon-zinc) or rechargeable (nickel-cadmium) batteries.
- Do not mix new and used batteries. Only batteries of the same or equivalent type recommended should be used.
- Remove exhausted batteries from the toy; do not short-circuit supply terminals.
- Remove all batteries if the toy will not be used for a long period of time.

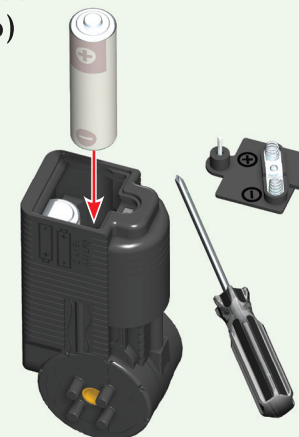

Important Tips

- Alkaline batteries are recommended.
- Rechargeable batteries are not recommended.
- Remove rechargeable batteries before recharging; they must be charged only under adult supervision.
- Non-rechargeable batteries must not be recharged.
- Keep components free of dust; do not immerse or use in water.
- Do not dispose of batteries in a fire; they could leak or explode and cause injury.
- Do not put rods smaller than 2 inches in any openings of the motor; they will damage the motor and cannot be removed.



The wheelie bin indicates this product cannot be disposed of with household waste due to presence of hazardous substances.

To protect human health and environment, check your local authority for recycling advice and facilities (2012/19/EU, Europe only).

Gardez précieusement cette notice pour vous y référer ultérieurement

Informations Importantes pour les Parents et les Enfants



ATTENTION : RISQUE D'ÉTOUFFEMENT - Pièces de petite taille. Ne convient pas aux enfants de moins de 3 ans.

ATTENTION : Gardez les cheveux, les doigts, la figure et les vêtements à l'écart de toutes les pièces mobiles.

ATTENTION : Faire attention de ne pas renverser le modèle. Le modèle devrait être placé sur une surface plate et dure.

- Ne pas bloquer les rails avec des objets ou la corps.
- Partage l'expérience K'NEX avec ton enfant et fais du montage K'NEX un agréable projet de famille.
- Prends ton temps lors du montage. Ne te presse pas.
- Essaie de situer ton modèle dans le même sens que les instructions durant le montage.
- Le produit et les couleurs peuvent varier.

Allez k'nex.com à pour les mises à jour d'instruction

Informations sur les Piles

Comment mettre et retirer des piles

Utiliser un petit tournevis pour desserrer la vis et pour enlever le couvercle des piles. Insérer 2 piles AA (LR6)** neuves dans le compartiment en respectant la polarité (+/-).

Installe les piles avant de réaliser tes constructions.

** Pas inclus



ATTENTION : Pour éviter la fuite des piles

- Insérez les piles en respectant la polarité (+/-) comme indiqué.
- Ne pas mélanger différents types de piles.
- Ne pas mélanger des piles alcalines avec des piles standard (carbone-zinc), ou des piles rechargeables (au nickel-cadmium).
- Ne pas mélanger des piles neuves avec des piles usées. Il convient d'utiliser uniquement des piles du type recommandé ou d'un type équivalent.
- Retirer toujours les piles faibles ou mortes du produit ; ne pas faire court-circuiter les terminaux.
- Ne pas jeter les piles dans le feu ; elles risqueraient de fuir ou d'exploser et d'entraîner des blessures.

Conseils Importants

- Les piles alcalines sont recommandées.
- Les piles rechargeables ne sont pas recommandées.
- Retirer les piles rechargeables du jouet avant de les recharger; elles doivent être chargées exclusivement en présence d'un adulte.
- Les piles qui ne sont pas rechargeables ne doivent pas être rechargées.
- Veiller à ce que les éléments restent à l'abri de la poussière ; ne pas les plonger ni les utiliser dans l'eau.
- Ne pas jeter les piles dans le feu ; elles risqueraient de fuir ou d'exploser et d'entraîner des blessures.
- N'insérez pas de tige trop courte dans le moteur, elle pourrait rester coincée et l'endommager.



Le symbole "poubelle à roulettes" indique que ce produit ne peut pas être éliminé avec vos déchets ménagers en raison de la présence de substances dangereuses.

Afin de protéger votre santé et l'environnement, renseignez-vous auprès de vos autorités locales afin d'obtenir des conseils sur le recyclage et la localisation des installations adaptées (2012/19/EU, Europe uniquement).

Empieza a construir

Para comenzar tu modelo, busca el **1** y sigue los números. Cada pieza tiene su propia forma y color. Simplemente mira los dibujos, busca las piezas correspondientes en tu juego y después conéctalas. Mientras construyes, trata de colocar tu modelo en la misma dirección que se muestra en las instrucciones. Los colores desteñidos muestran que esta sección ya está construida. Conecta las nuevas secciones en los lugares señalados por las flechas. Las nuevas piezas que agregues estarán en colores vivos.

Inicia a construção

Para começar o teu modelo, procura o **1** e segue os números. Cada peça tem a sua própria forma definida e cor. Basta simplesmente olhares para a ilustração, procurar as peças do teu jogo correspondentes às que estás a ver e, em seguida, conectar umas nas outras. Enquanto estás a montar as peças, tenta manter o teu modelo na mesma direcção, conforme mostrado na ilustração, para assim ligares as peças correctamente. As cores desbotadas indicam que esta secção já está montada. Passarás então a fazer a conexão da nova secção no local indicado pelas setas.

Start Building

To begin your model, find the **1** and follow the numbers. Each piece has its own shape and color. Just look at the pictures, find the pieces in your set that match and then connect them together. Try to face your model in the same direction as the instructions while you build. The arrows show you where the parts connect, but not all connections points have arrows. Faded colors show you this section is already built.

Démarre ta Construction

Pour commencer le modèle, cherche l'étape numéro **1** et suis les numéros dans l'ordre. Chaque pièce a sa propre forme et sa propre couleur. Regarde les illustrations, trouve les pièces qui y correspondent et les assemble-les. Pour te faciliter la tâche, oriente le modèle dans le même sens que les instructions. Les flèches indiquent où les pièces s'assemblent, mais les points de raccordement n'ont pas tous des flèches. Les pièces ayant une couleur estompée sont celles déjà assemblées.

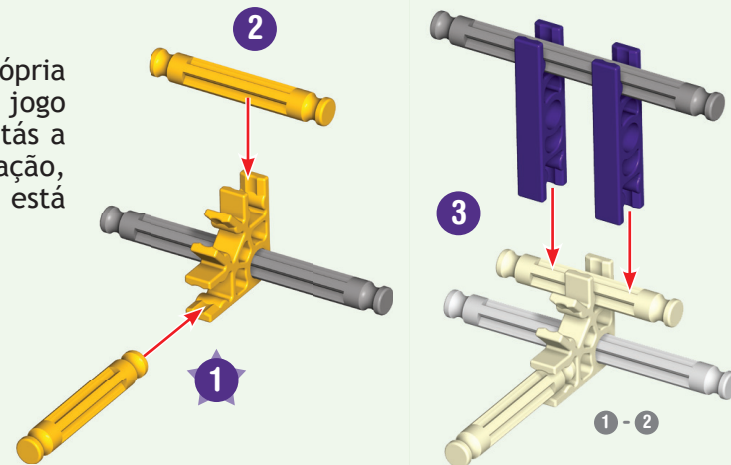

Conectores

Hay conectores con ranuras largas especiales. Se enganchan deslizándose como ves en los dibujos. Conecta estas piezas empujándolas hasta que oigas “clic”.

Conectores É muito importante que posiciones os conectores numa direcção específica. Presta muita atenção às instruções e coloca estes conectores horizontal ou verticalmente, exactamente conforme se mostra nas ilustrações. Junta as partes simultaneamente e com firmeza até ouvires um “estalido”.

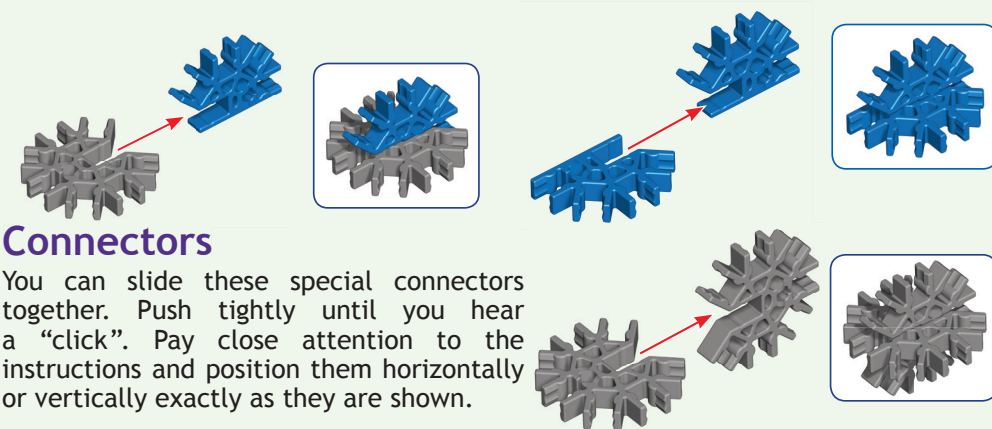

Connectors

You can slide these special connectors together. Push tightly until you hear a “click”. Pay close attention to the instructions and position them horizontally or vertically exactly as they are shown.

Connecteurs

Tu peux assembler ces connecteurs spéciaux en les faisant glisser l'un dans l'autre. Pousse fort jusqu'à entendre un « clic ». Lis attentivement les instructions et positionne-les horizontalement ou verticalement, en suivant exactement les illustrations.

Espaciadores

Hay lugares en tu modelo donde tendrás que agregar espaciadores azules y plateados. Cerciórate de usar el color correcto y cuéntalos con cuidado.

Espaçadores

Existirão certos pontos no teu modelo que necessitam a colocação de espaçadores azuis e prateados. Assegura-te que os contas cuidadosamente.



Spacers

There are places in your model where you need to add blue and silver spacers. Be sure to use the correct number of spacers shown in the instructions.

Séparateurs

Il y a des endroits sur le modèle où des séparateurs sont nécessaires. Assure-toi d'utiliser la bonne couleur et le nombre de séparateurs, comme indiqué sur les instructions.

Lista de Piezas

Antes de empezar con la construcción, asegúrate de comparar las piezas en tu conjunto con la lista de las piezas aquí. Si faltan algunas, llámanos o escríbenos siguiendo las instrucciones en la página trasera. Estamos aquí para ayudarte.

Lista de Peças

Antes de iniciares a construção, certifica-te de que comparas as peças do teu conjunto com a lista das peças aqui. Se faltar alguma peça telefona ou escreve-nos usando as informações indicadas na contracapa. Estamos aqui para te ajudar!



Parts List

Before you start building, be sure to compare the parts in your set with the parts list here. If anything is missing, call or write to us using the information on the back cover. We are here to help you!

Liste des Pièces

Avant de commencer à construire, assure-toi de comparer les pièces dans ta boîte à la liste de pièces fournie ici. S'il manque quelque chose, téléphone-nous ou écris-nous en te servant des informations figurant au verso de la notice. Nous sommes là pour t'aider !



CLOCK WORK
MONTAÑA RUSA
SET DE CONSTRUCCIÓN

CLOCK WORK
MONTANHA RUSSA
SET DE CONSTRUÇÃO

CLOCK WORK
ROLLER COASTER
BUILDING SET

HORLOGIE
MONTAGNES RUSSES
JEU DE CONSTRUCTION

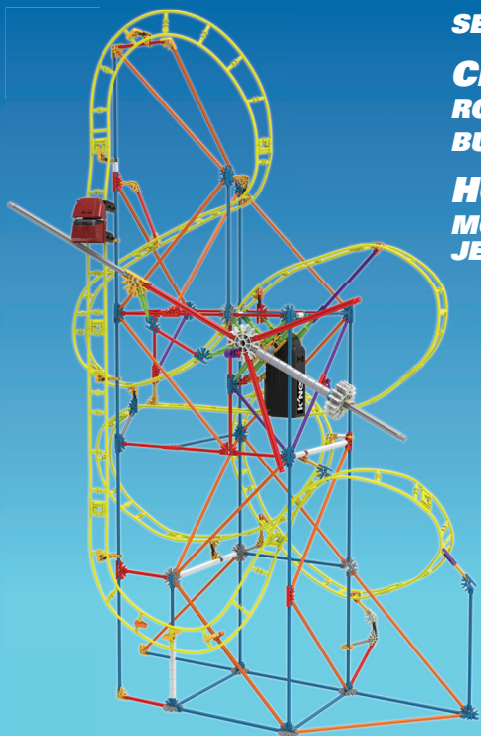

- | | | | | | |
|----|--|---|--|---|--|
| 18 | | 5 | | 2 | |
| 2 | | 2 | | 5 | |
| 3 | | | | | |
| 2 | | | | | |
| 3 | | | | | |
| 11 | | | | | |

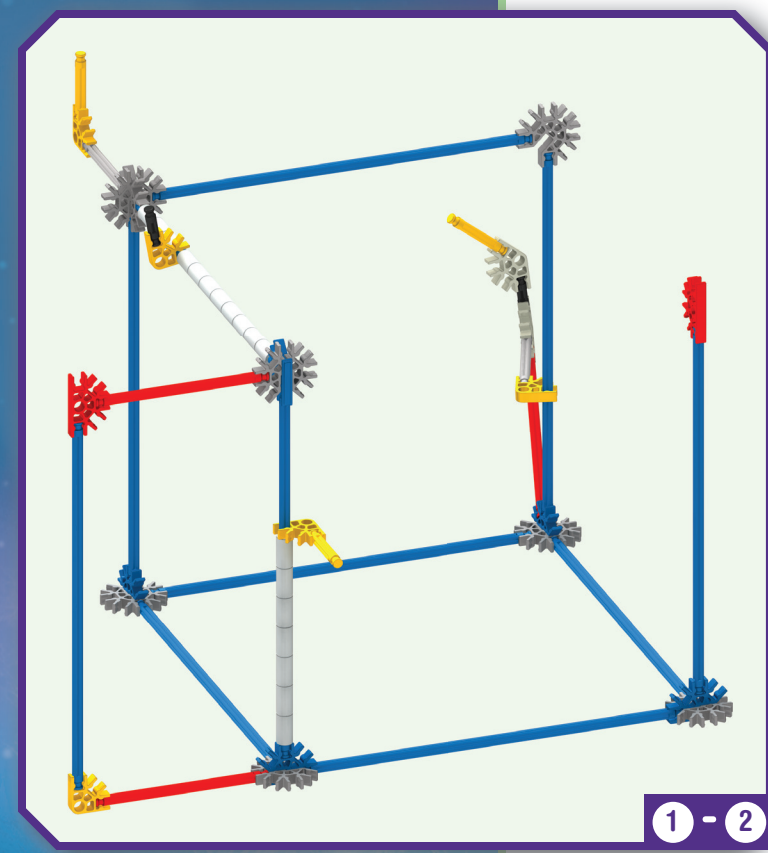
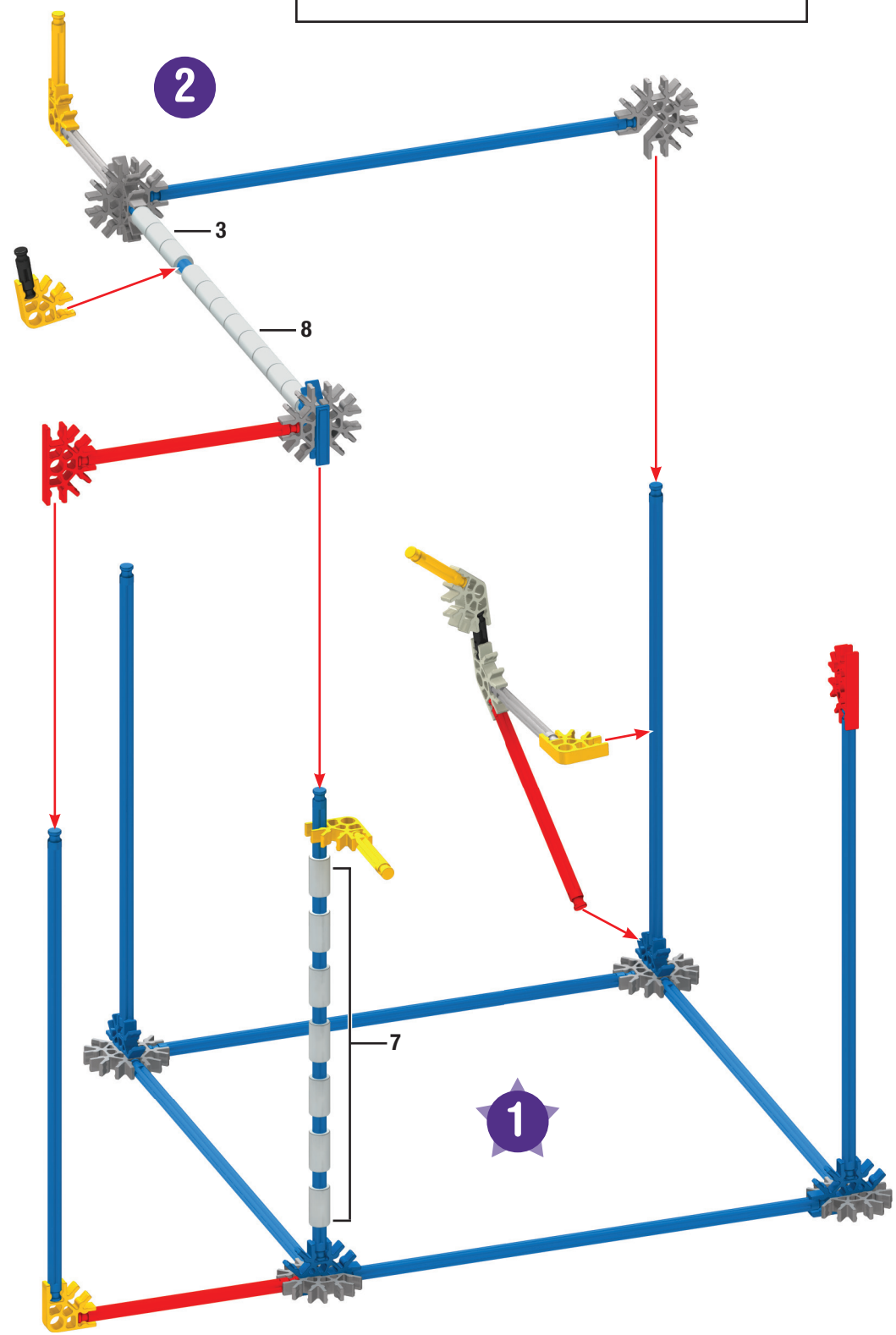

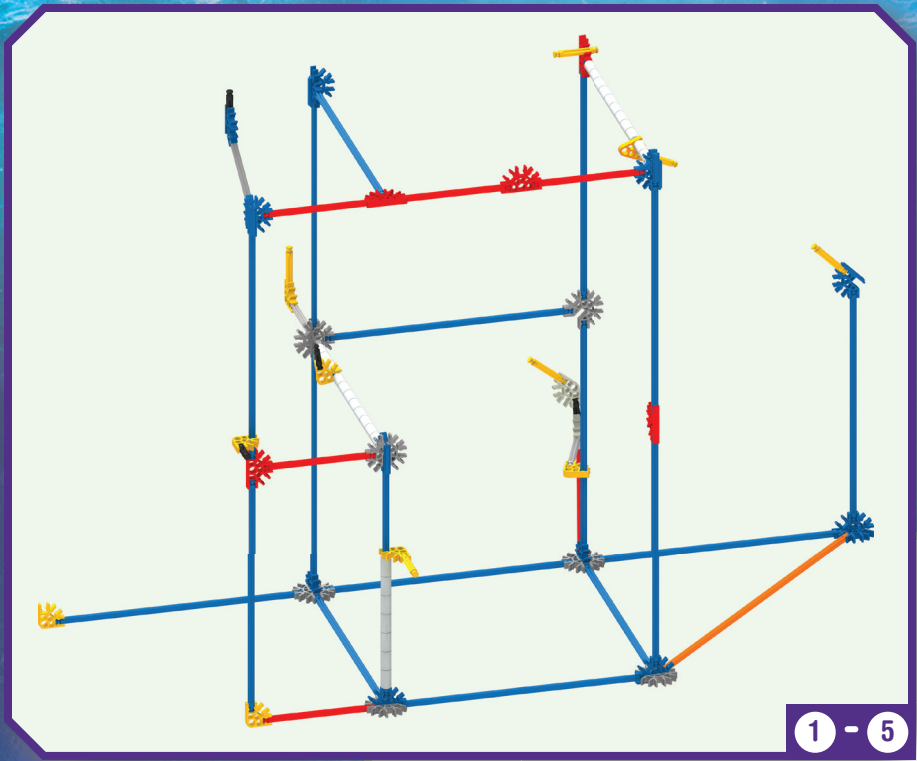

2		11		1		3		
3						2		
1							10	
3								
9								
1								

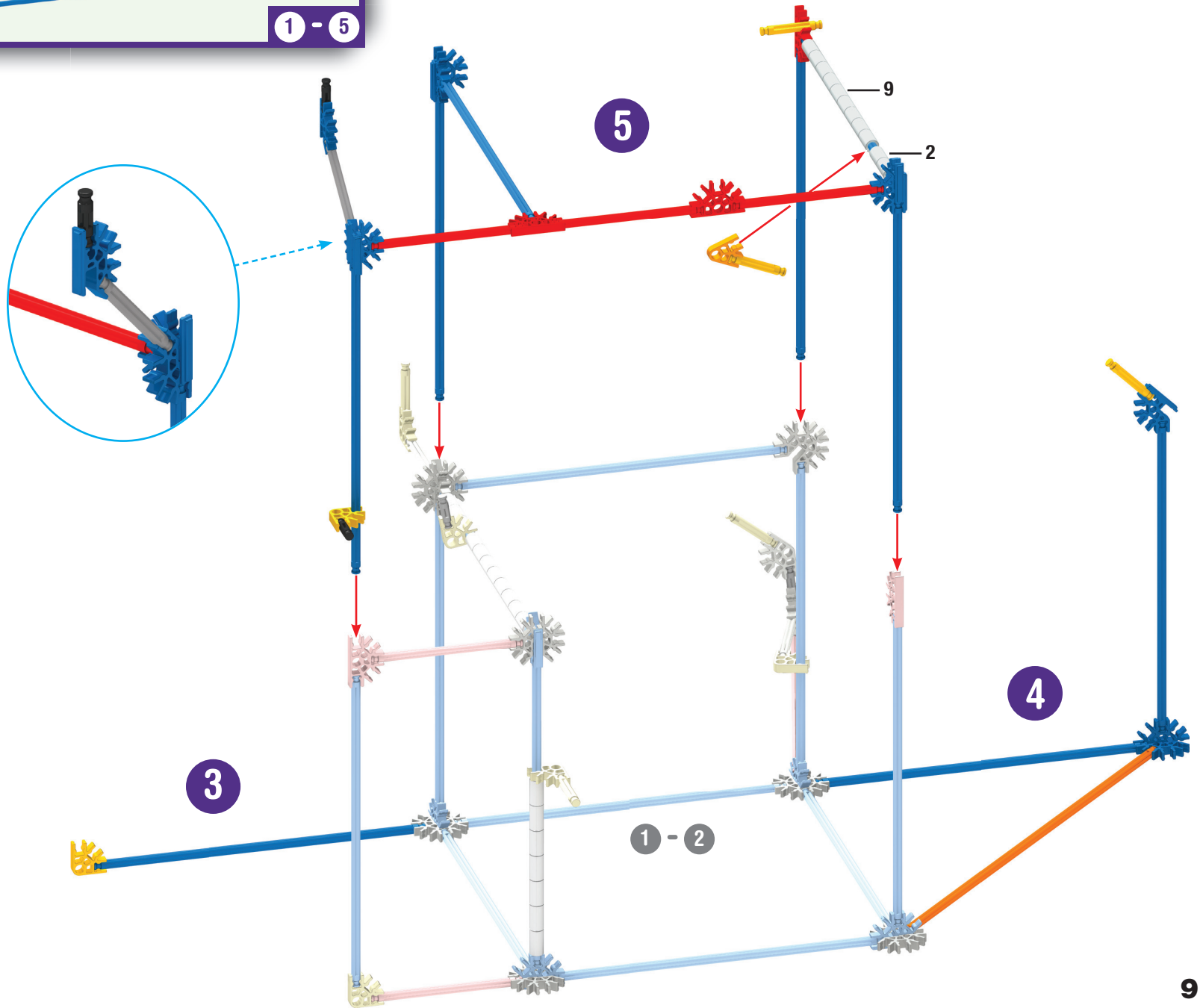

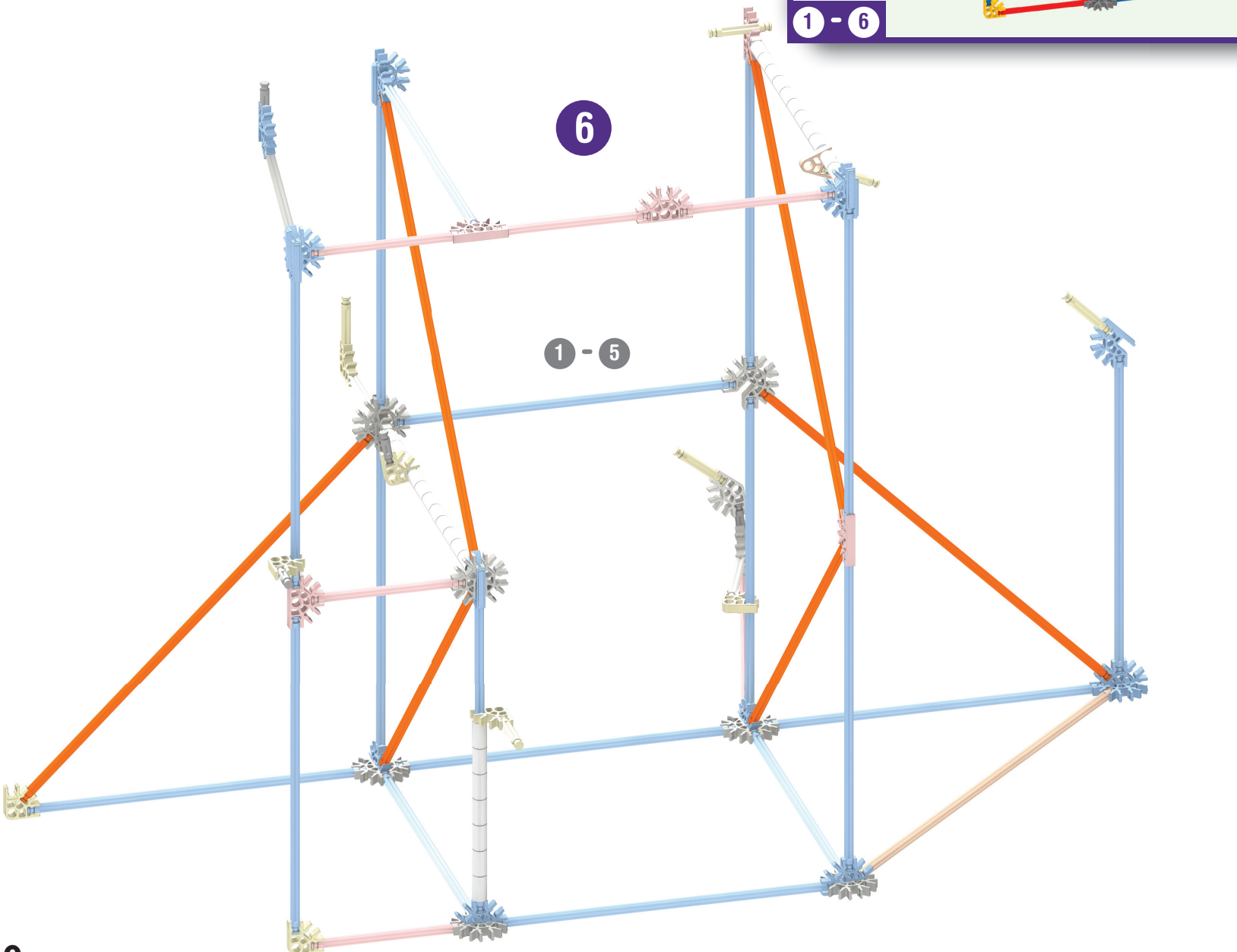
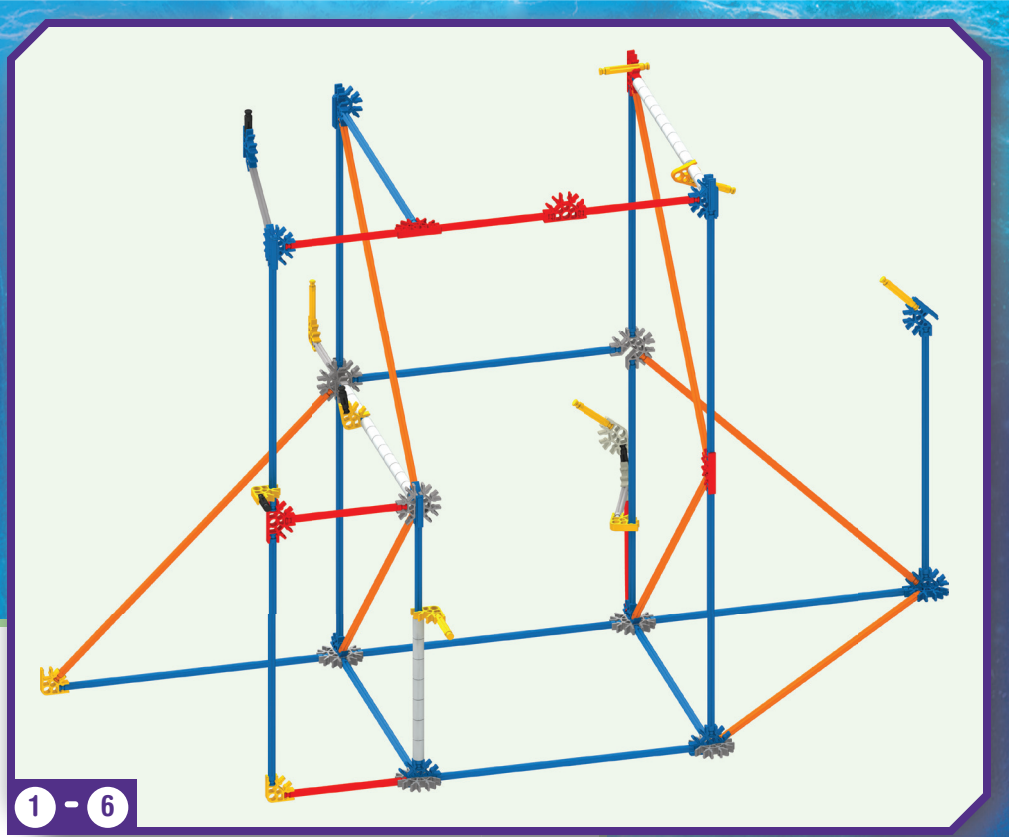

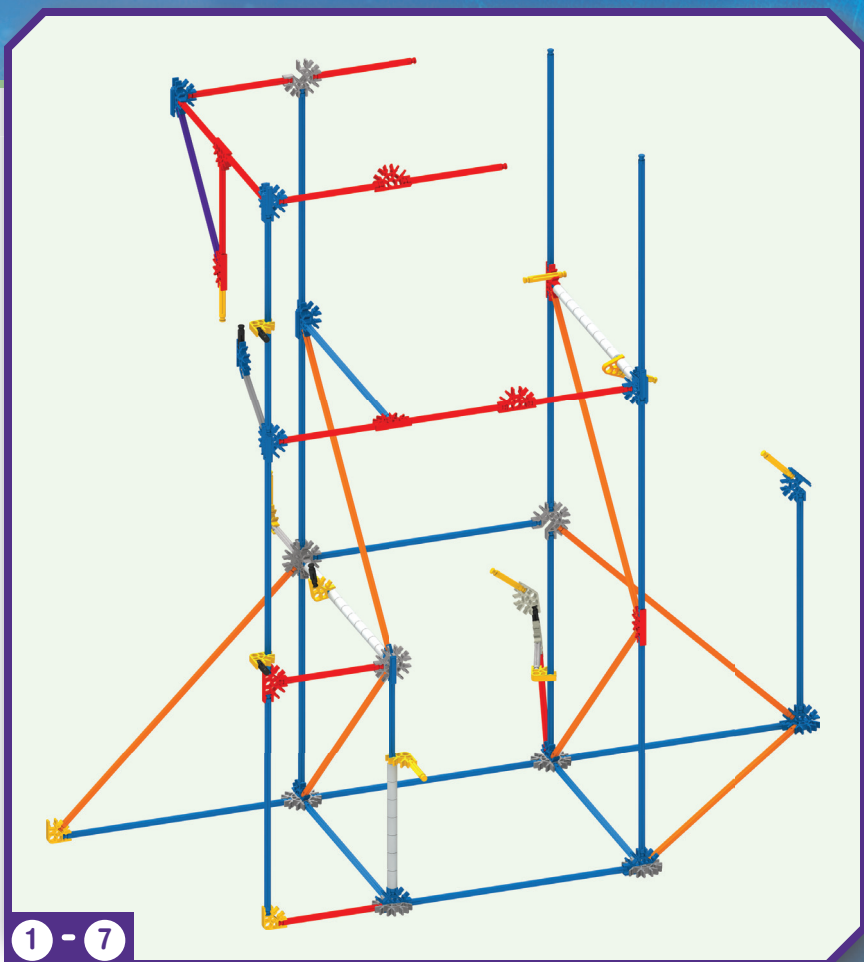
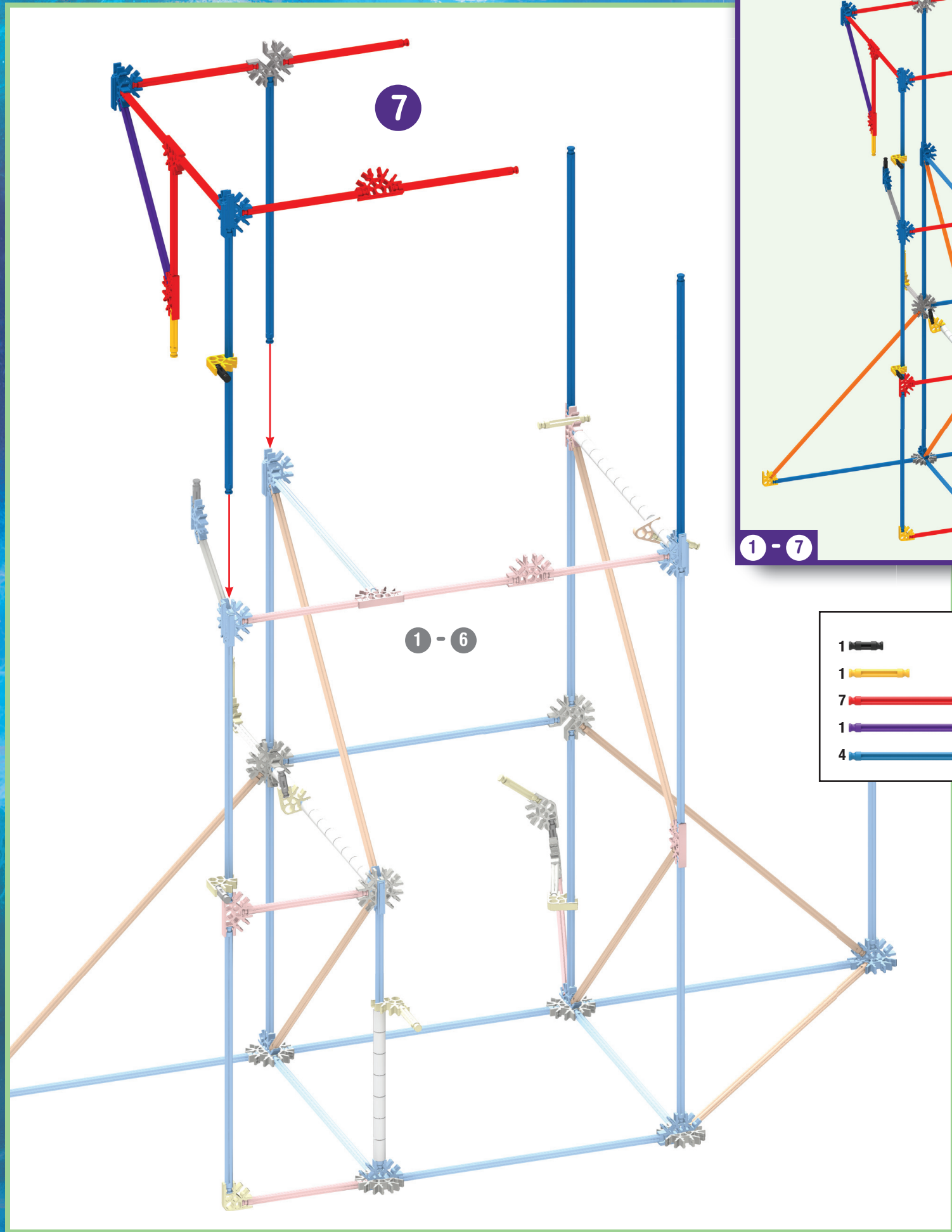

- | | | | | | |
|---|--|---|--|---|--|
| 1 | | 3 | | 4 | |
| 1 | | 1 | | 1 | |
| 7 | | | | | |
| 1 | | | | | |
| 4 | | | | | |

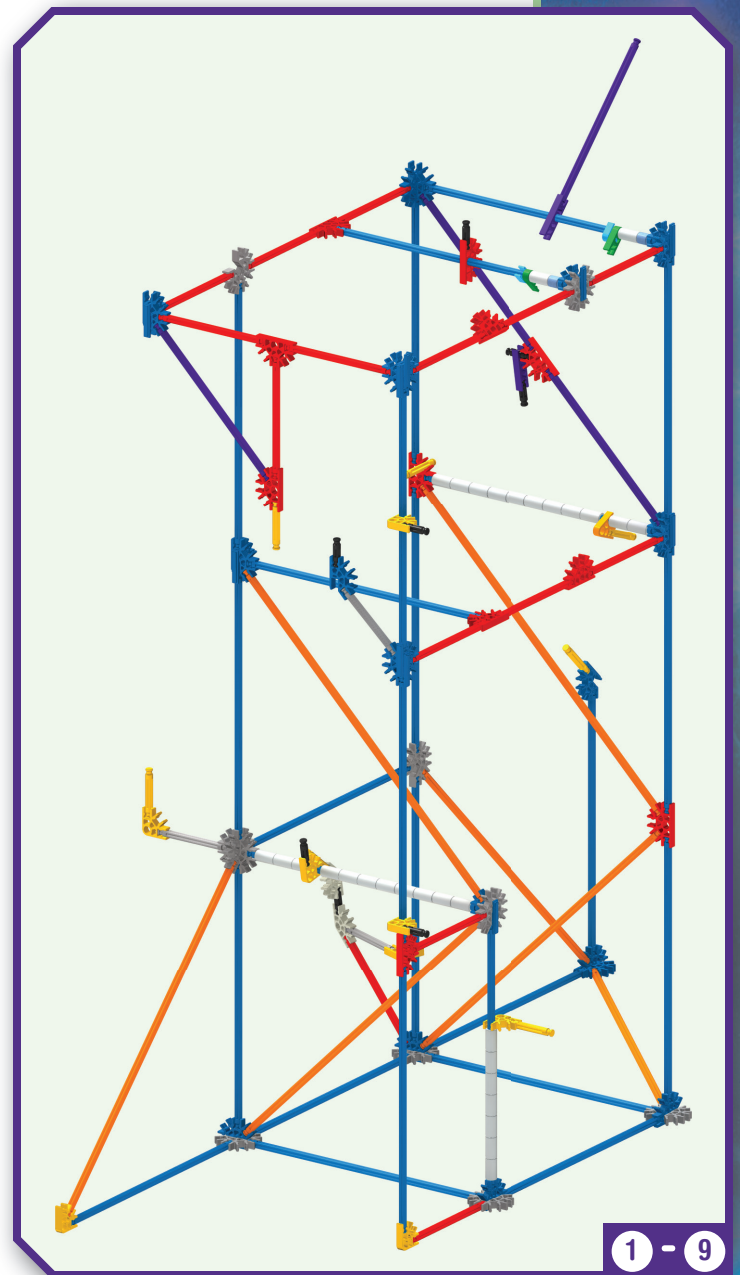
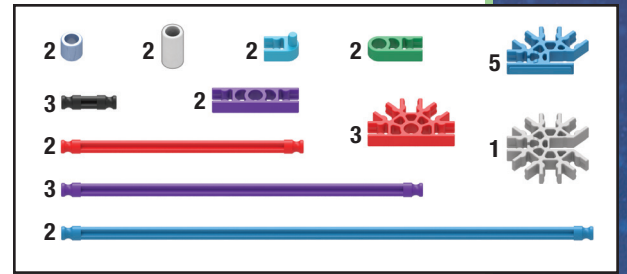
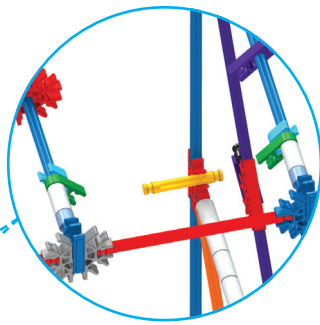
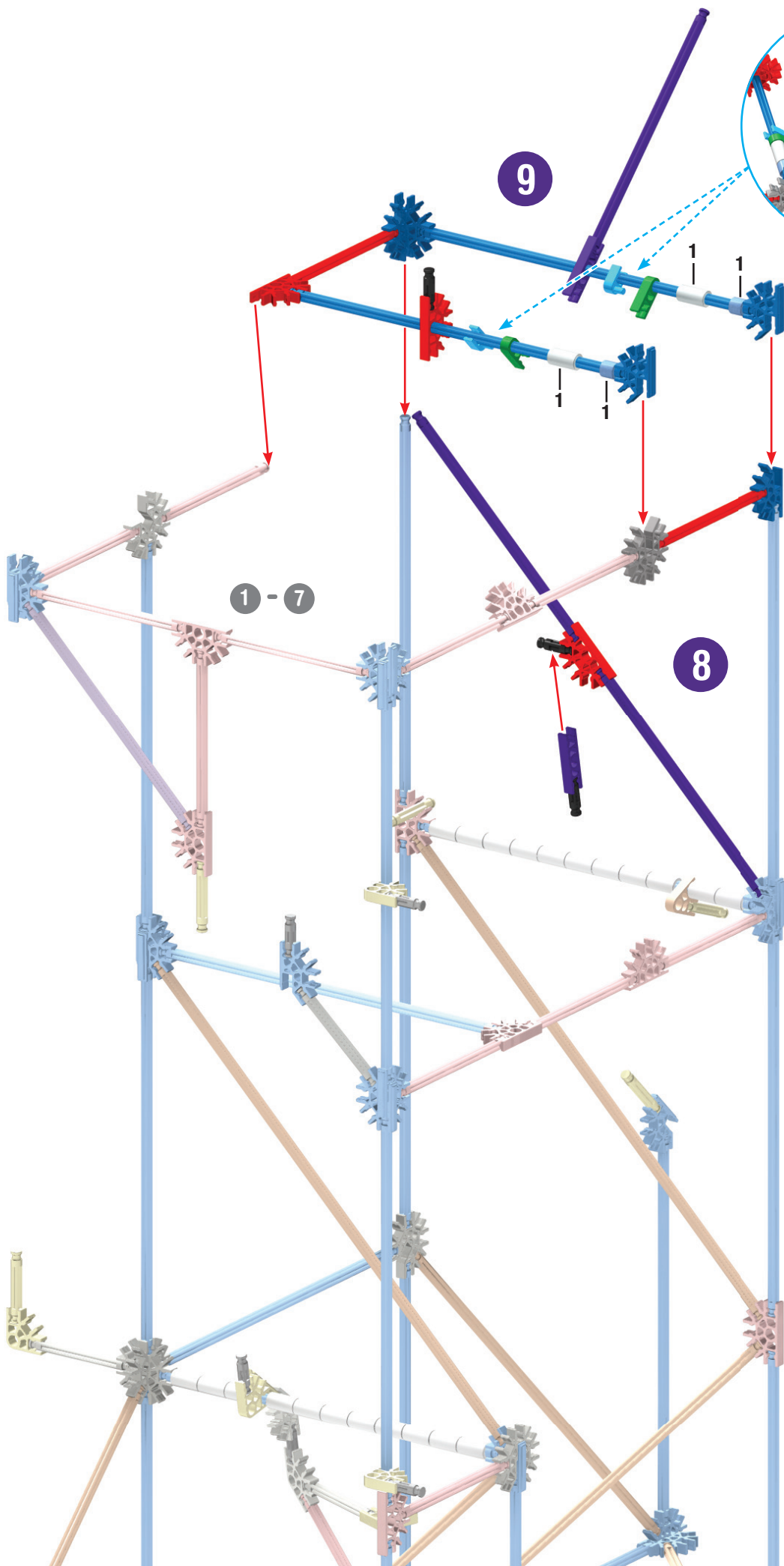

4		1		7		1	
2		2		4		4	
3							

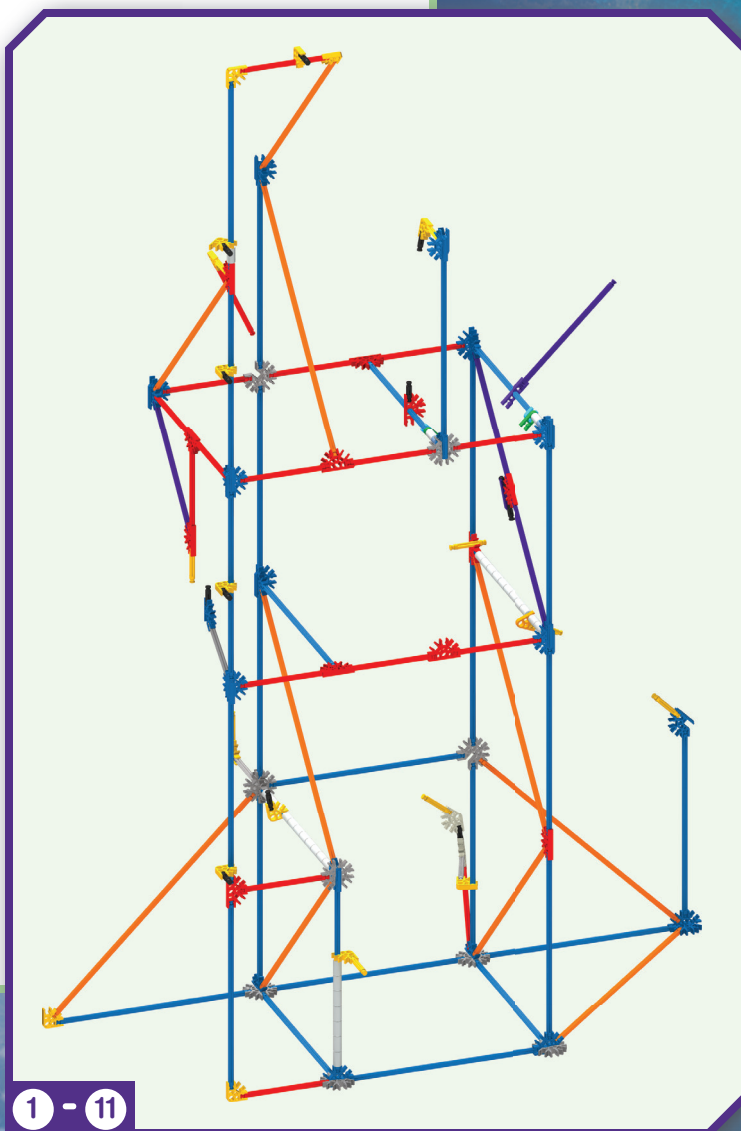
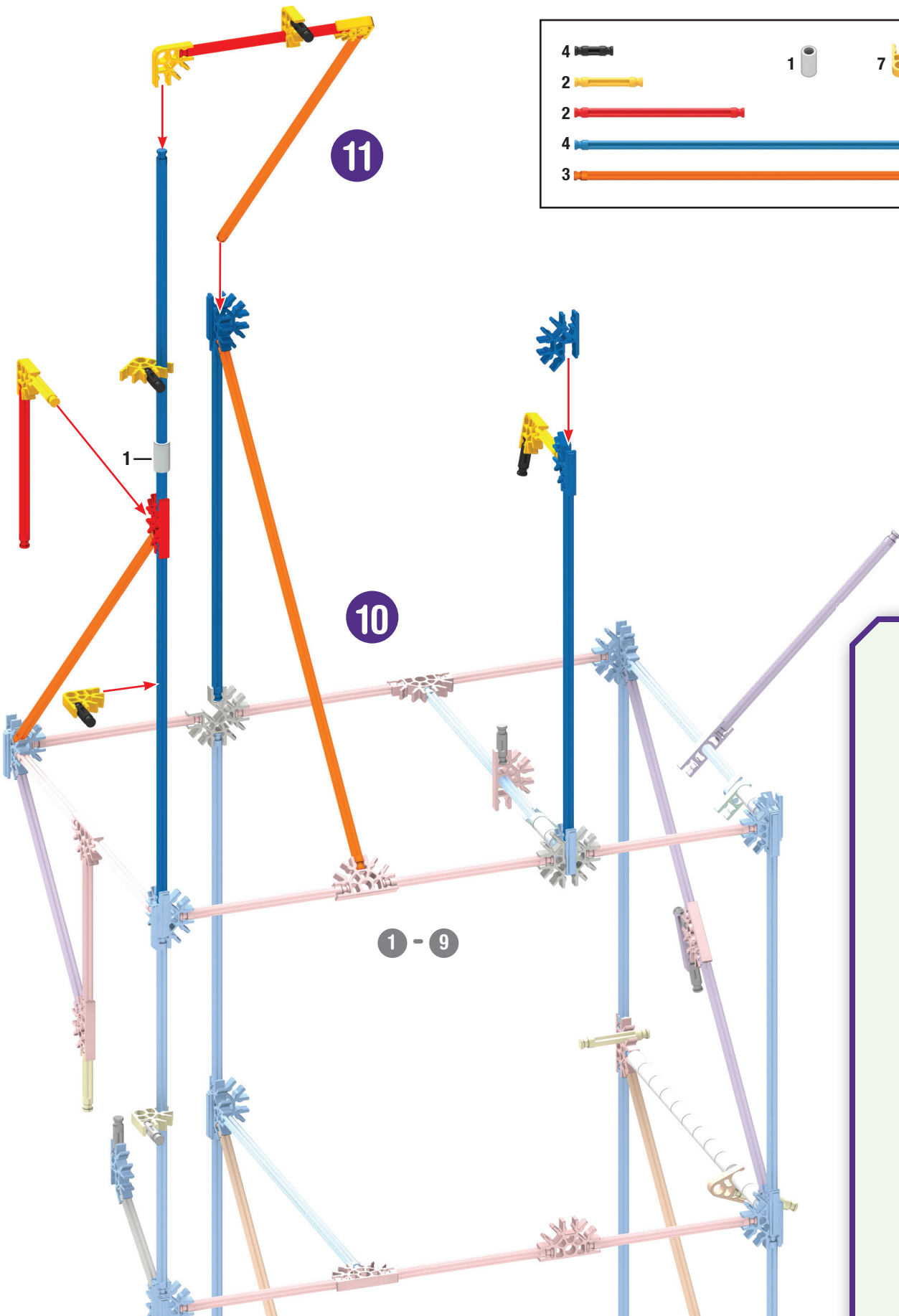

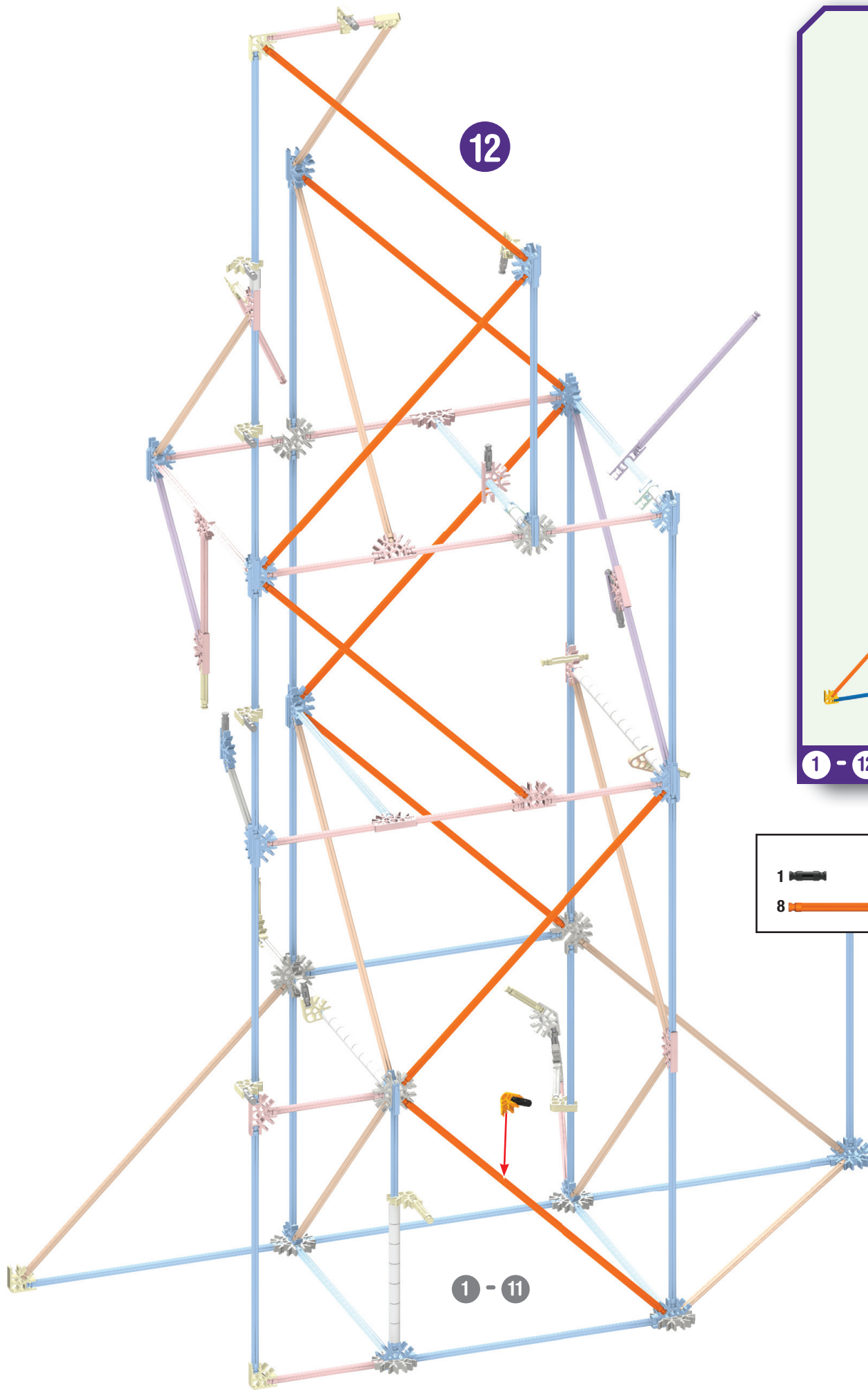

12

1 - 11

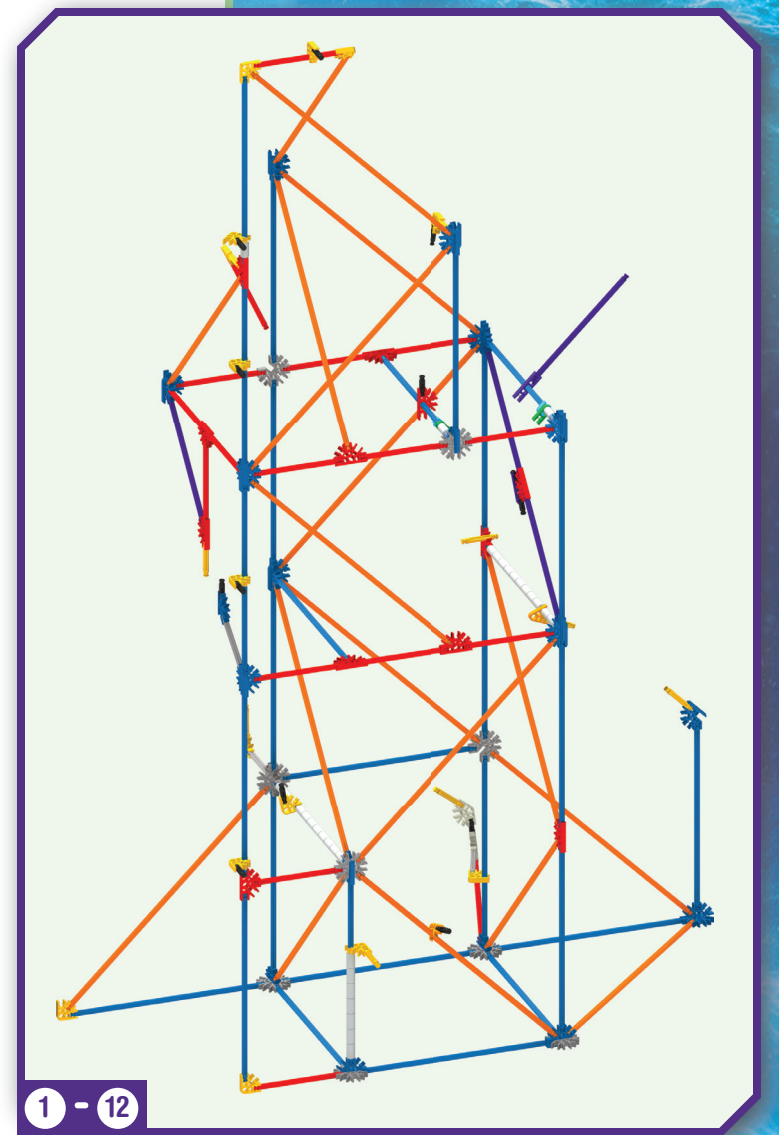

1 - 12

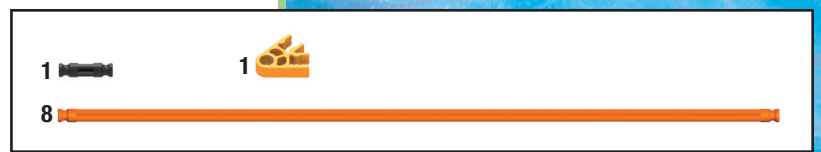

1

1

8

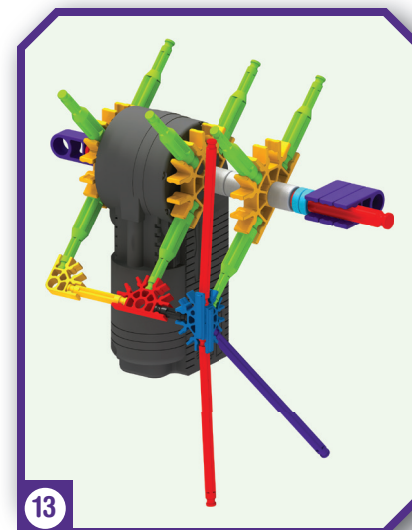
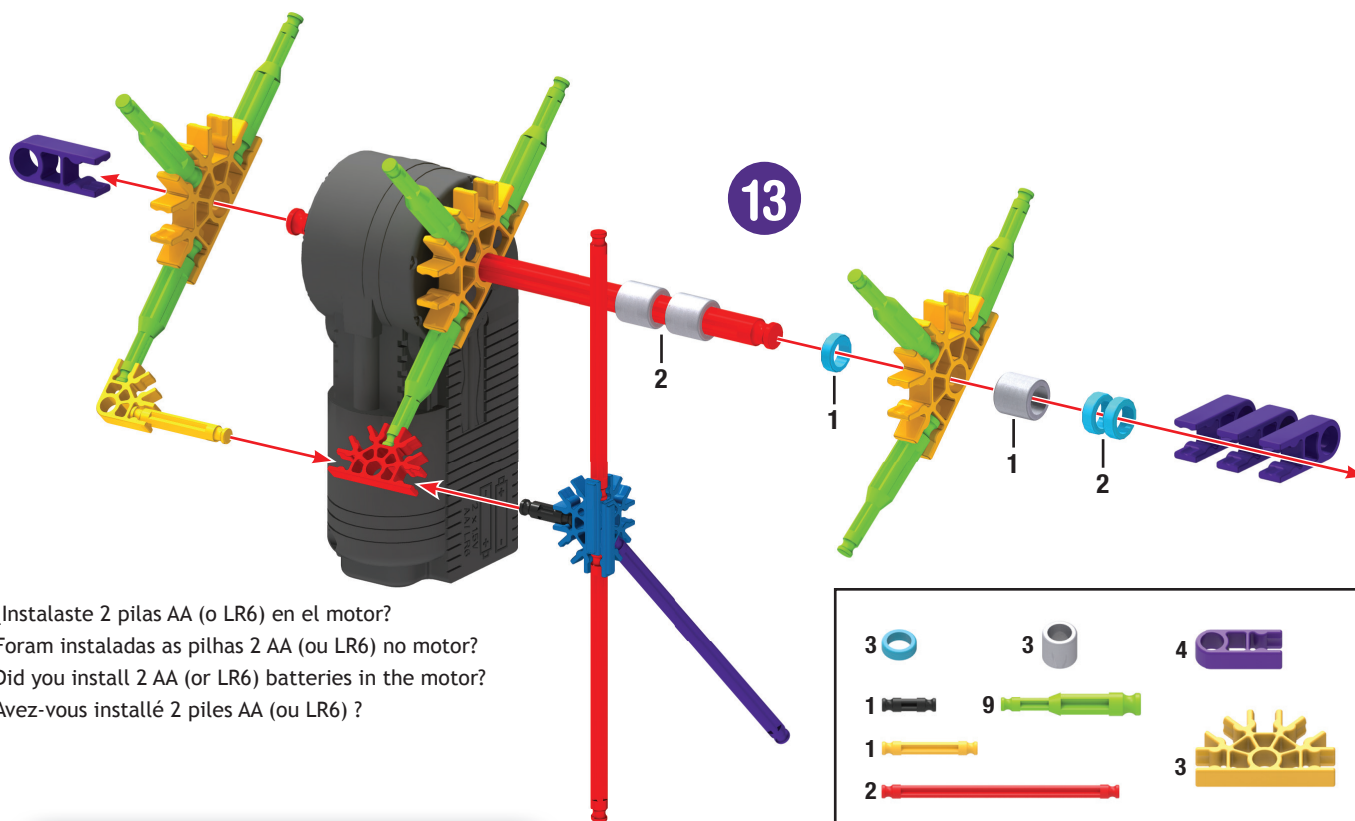

¿Instalaste 2 pilas AA (o LR6) en el motor?
 Foram instaladas as pilhas 2 AA (ou LR6) no motor?
 Did you install 2 AA (or LR6) batteries in the motor?
 Avez-vous installé 2 piles AA (ou LR6) ?

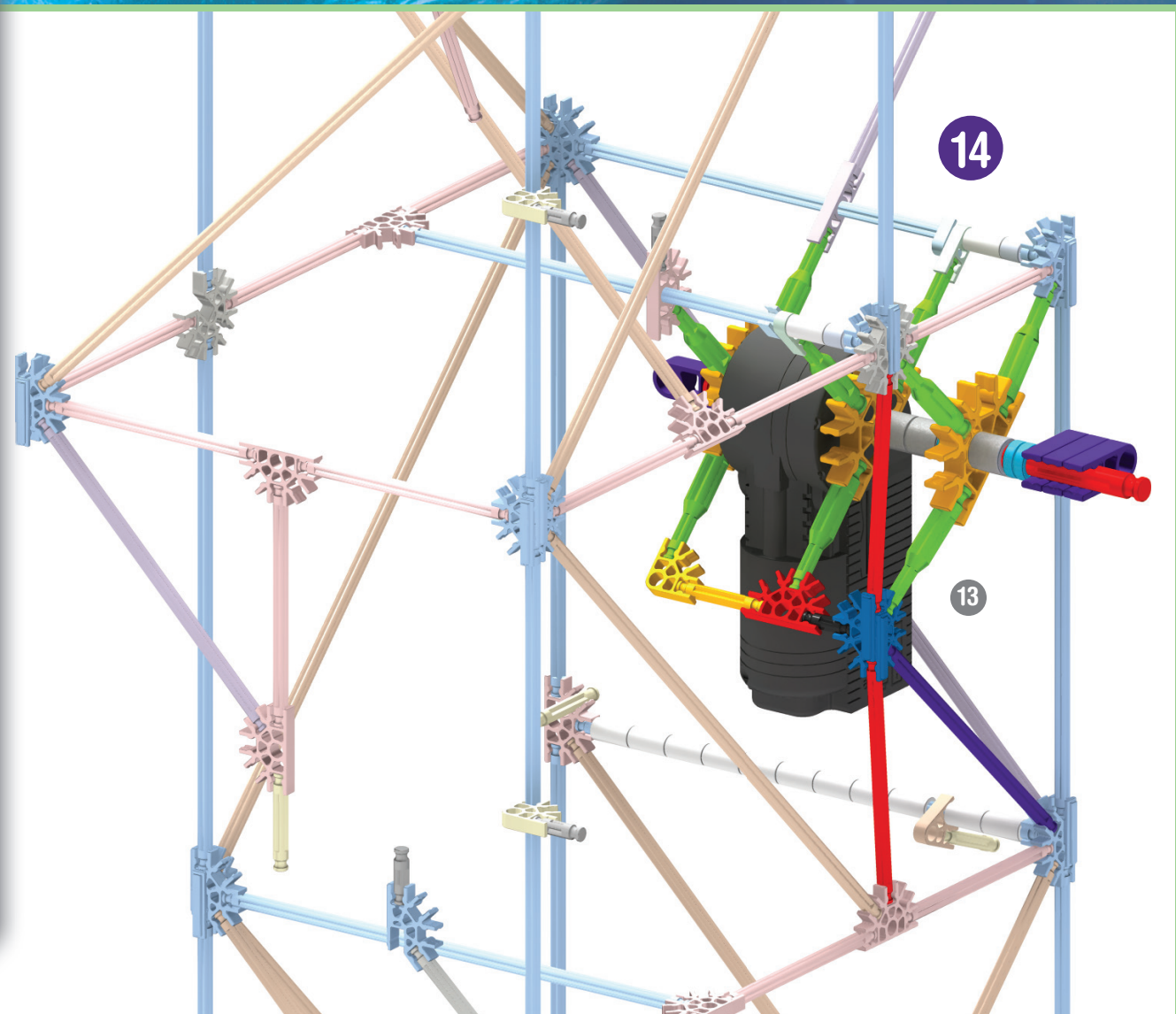
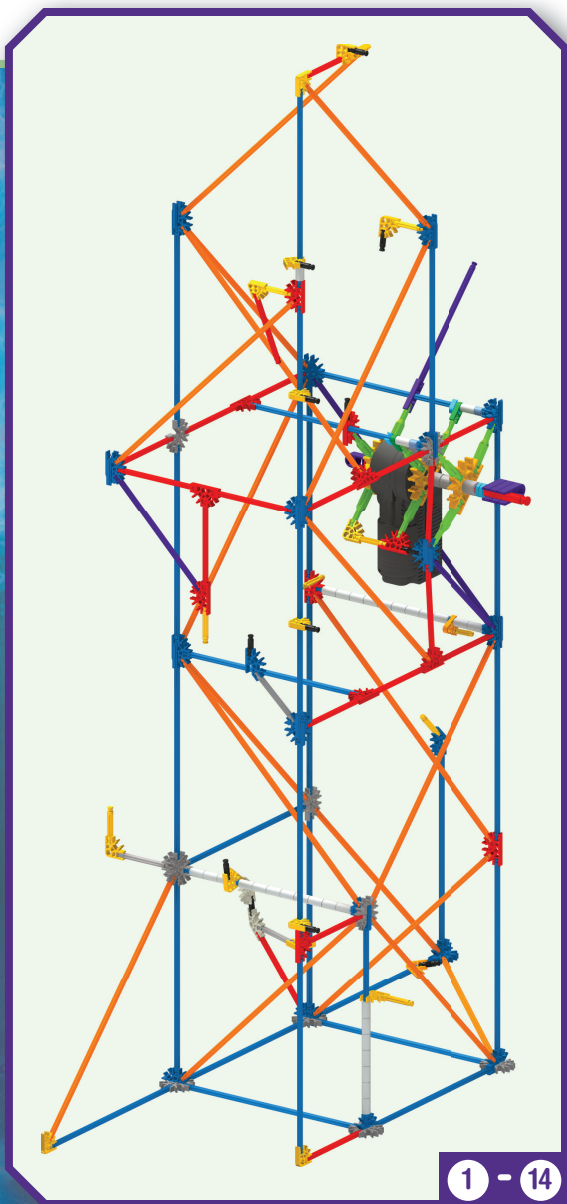
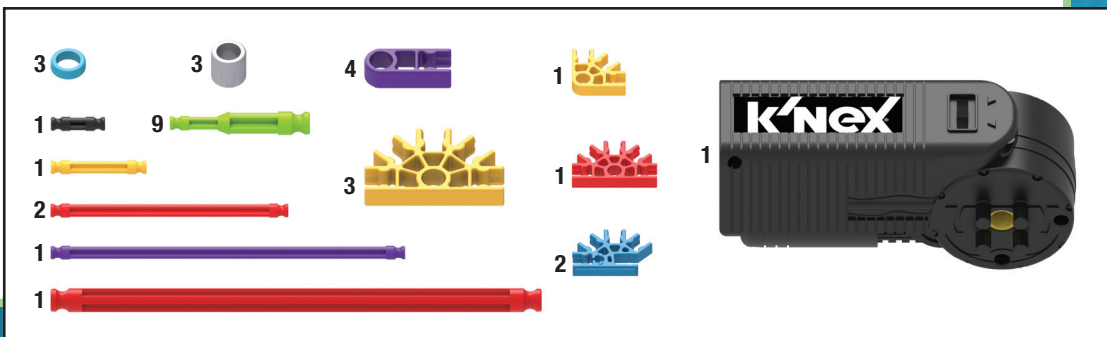

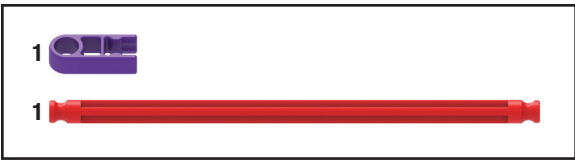
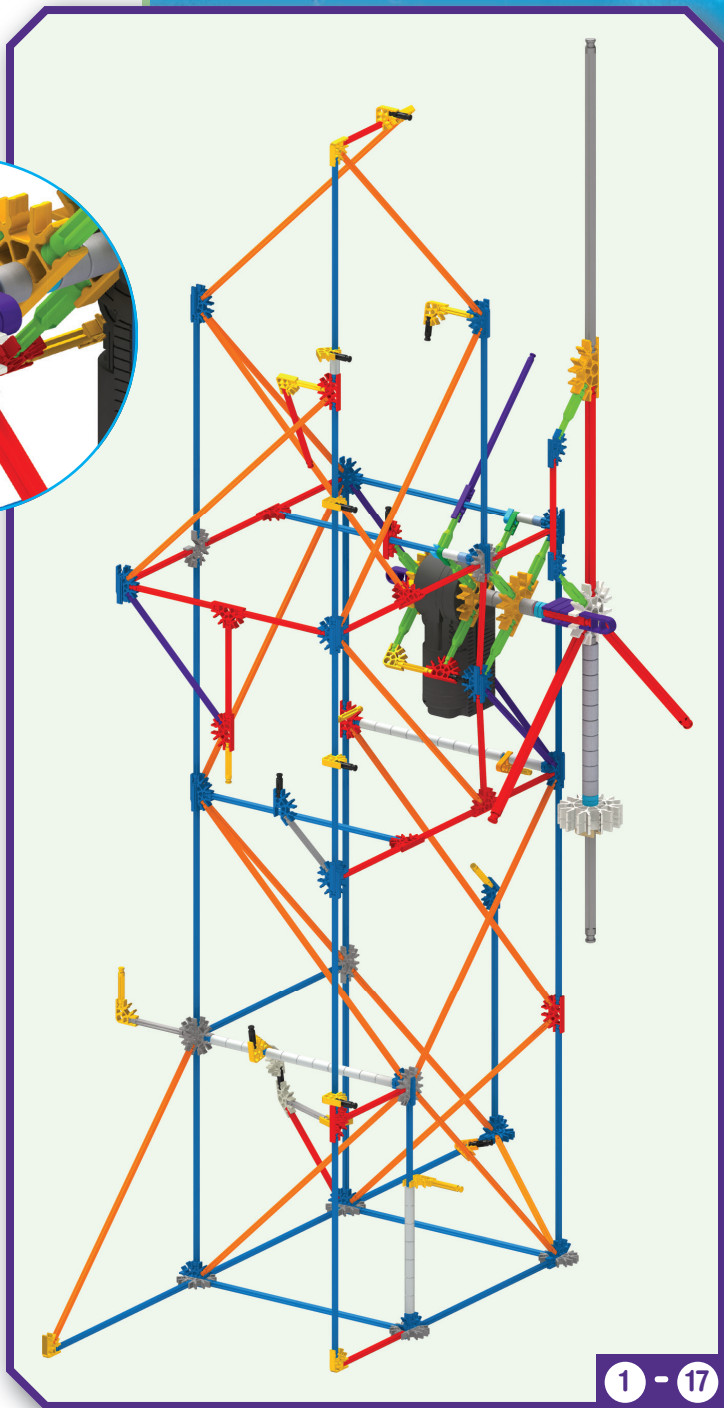
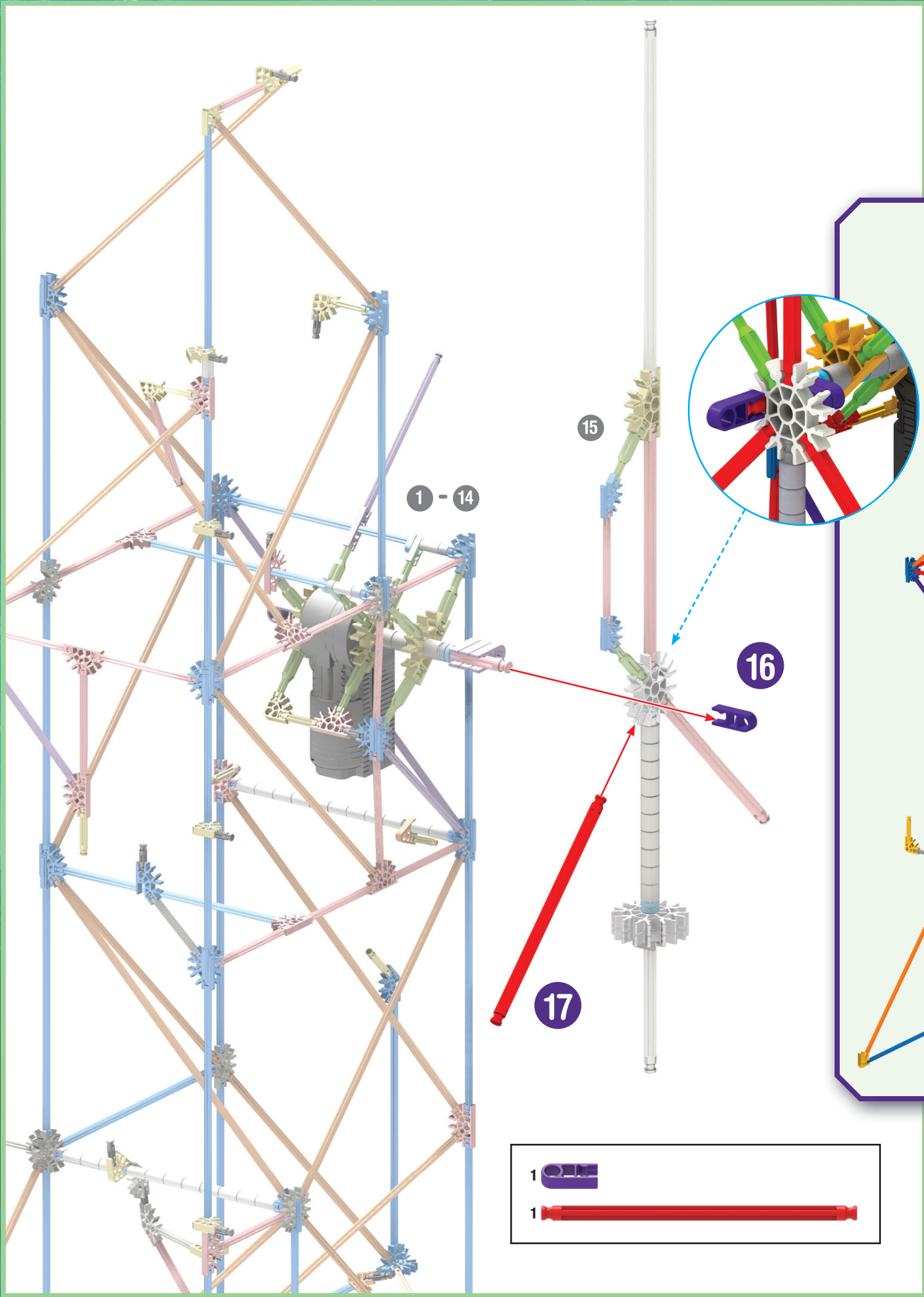

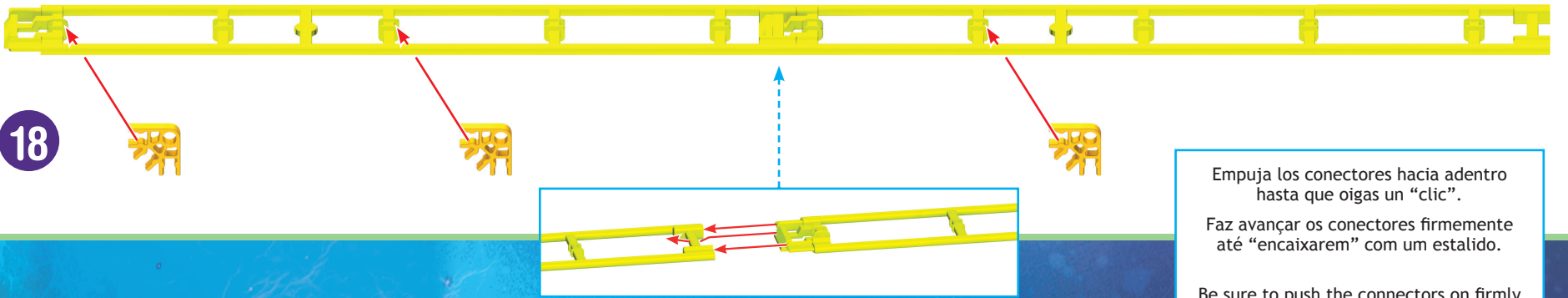

18

Empuja los conectores hacia adentro hasta que oigas un "clic".
 Faz avançar os conectores firmemente até "encaixarem" com um estalido.
 Be sure to push the connectors on firmly until they "click".
 Pousse bien les connecteurs jusqu'à ce qu'ils « cliquent ».

19

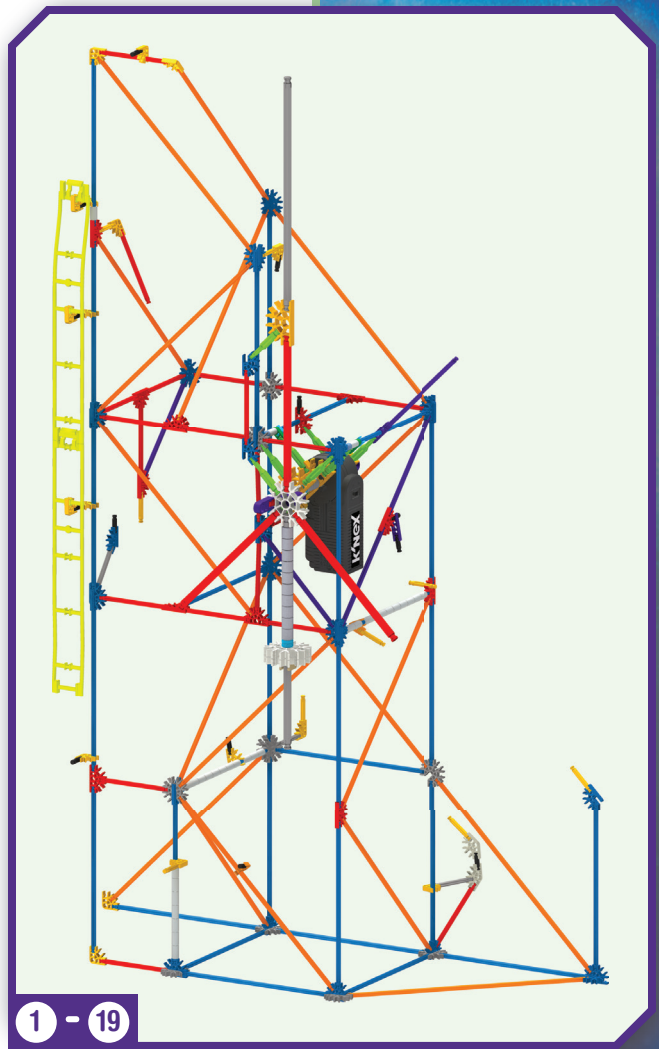
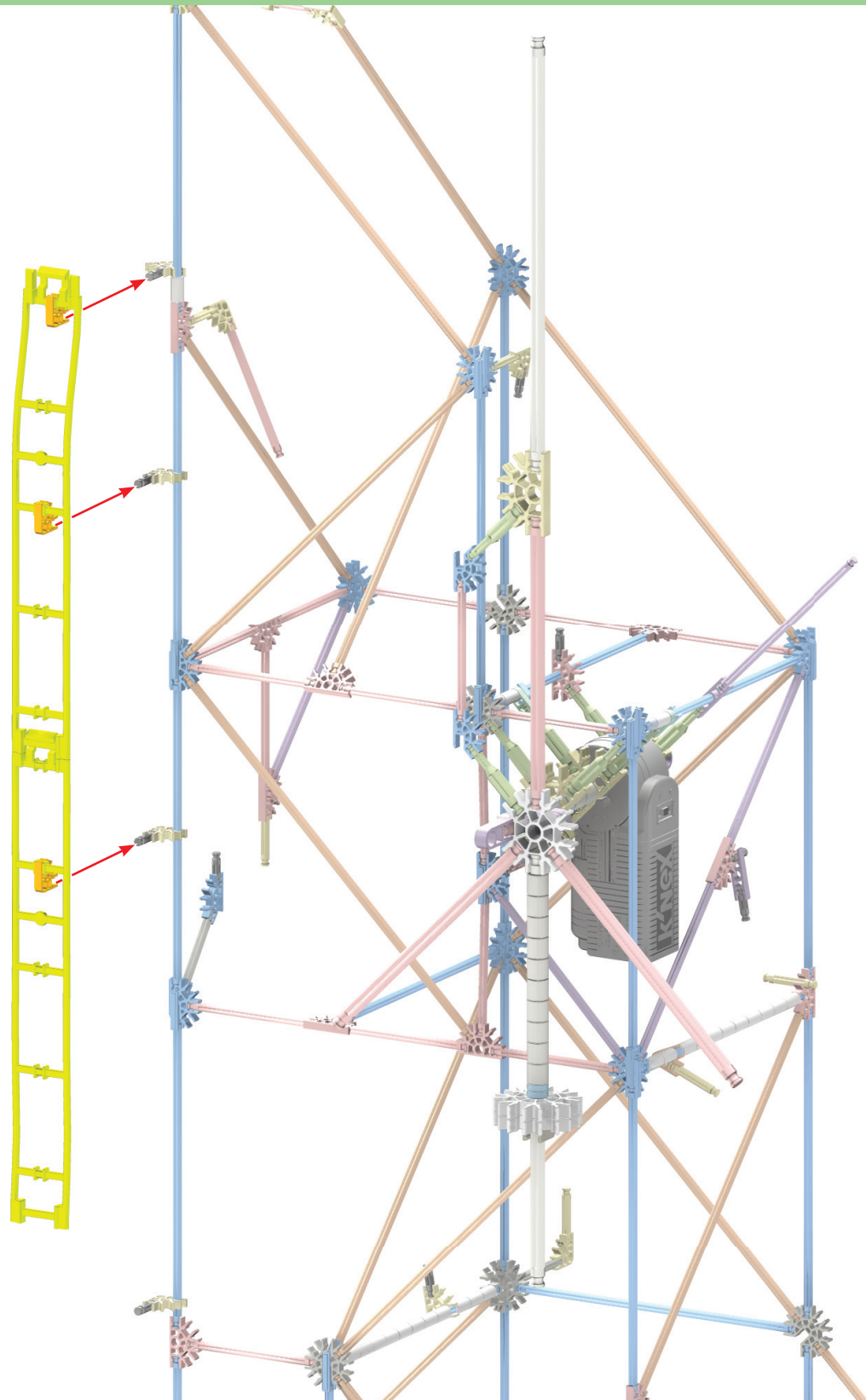

1 - 19

20

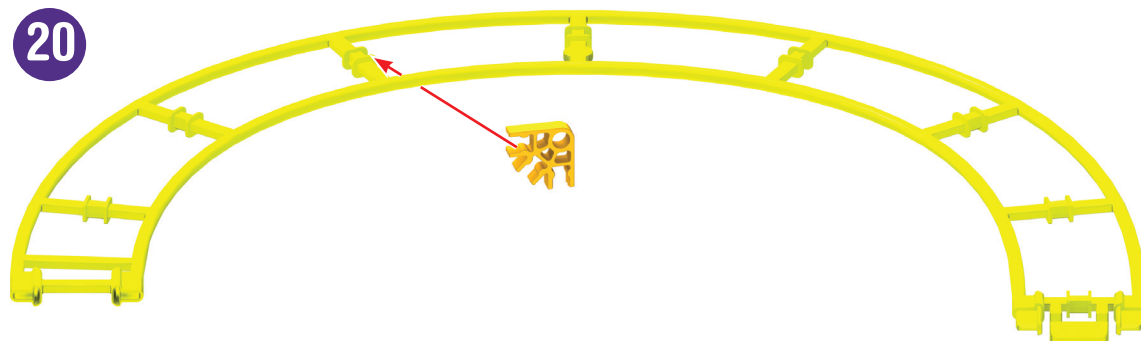

21

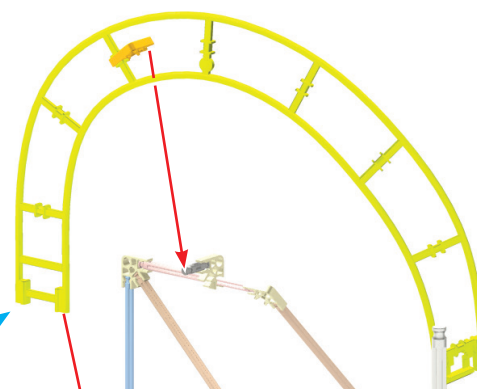

Siempre unir este extremo de la pista a la primera pieza de la pista anterior. Después, conecte el resto de la pista a la torre.

Sempre aderir a este final da trilha para a peça faixa anterior primeiro, e depois conectar o restante da trilha para a torre.

Always join this end of the track to the previous track piece first, then connect the rest of the track to the tower.

Toujours joindre à cette extrémité de la voie à la pièce de la piste précédente, puis connecter le reste de la piste à la tour.

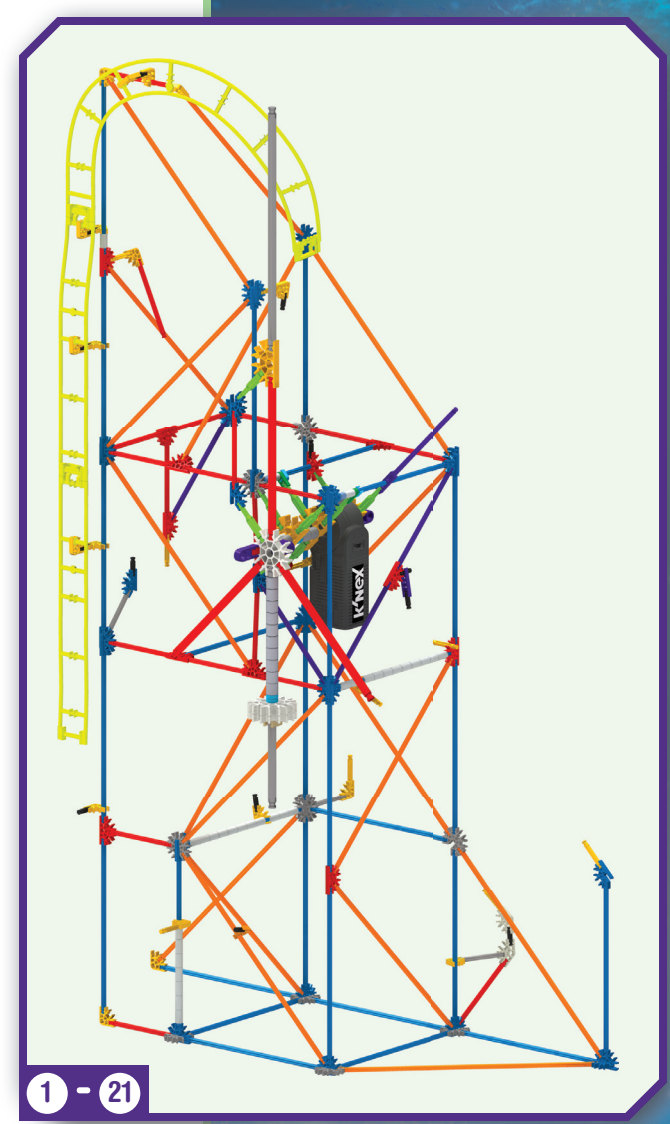
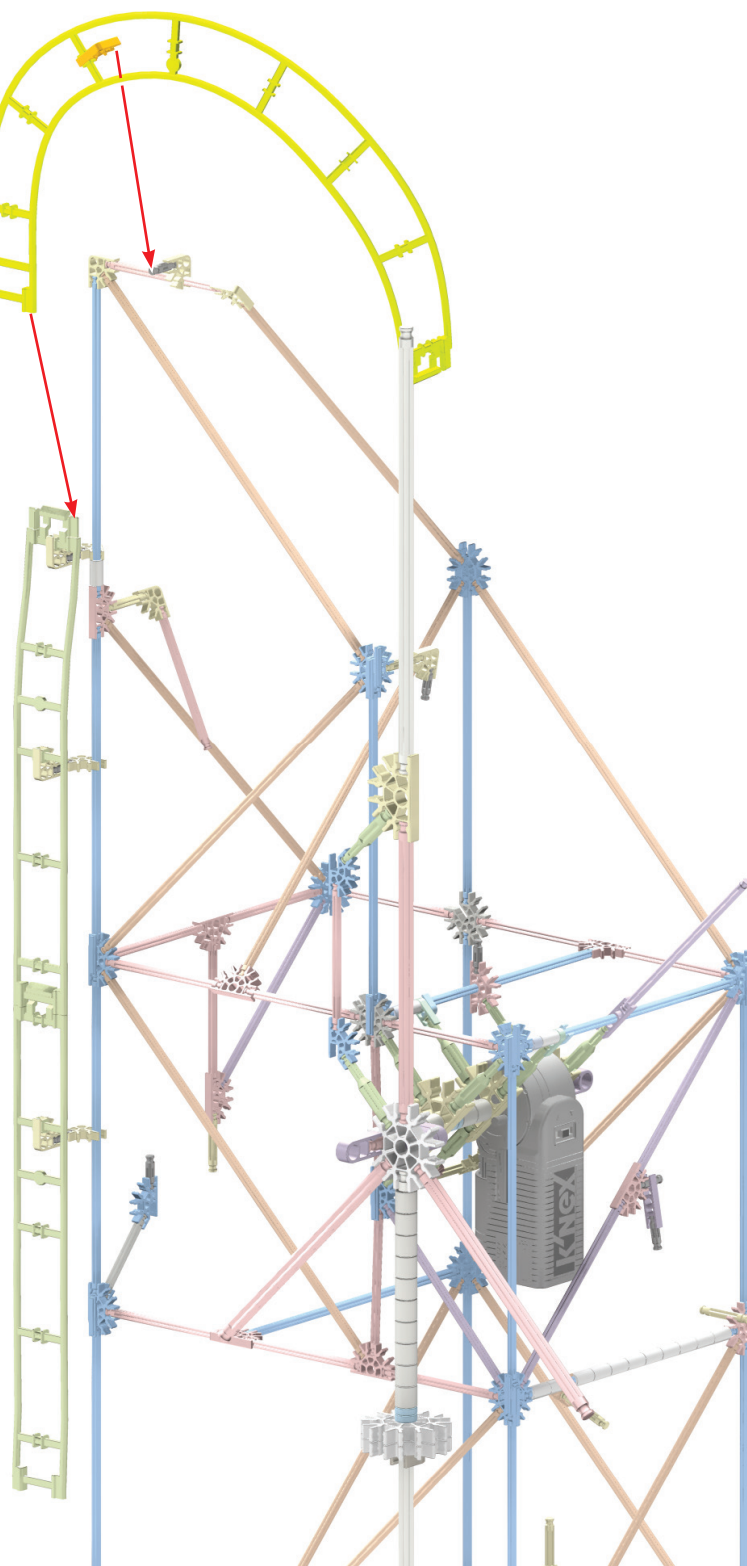

1 - 21

22

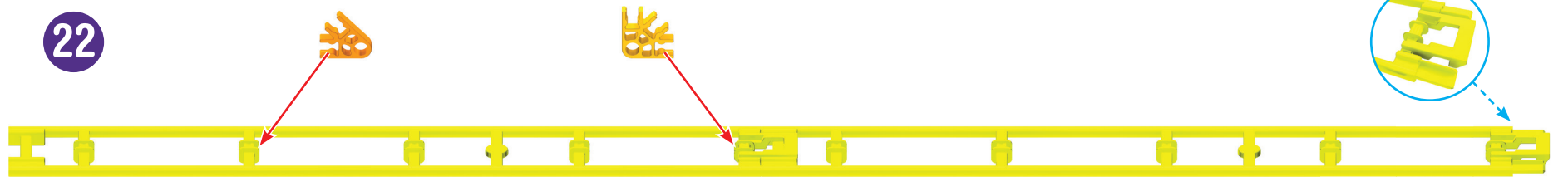

23

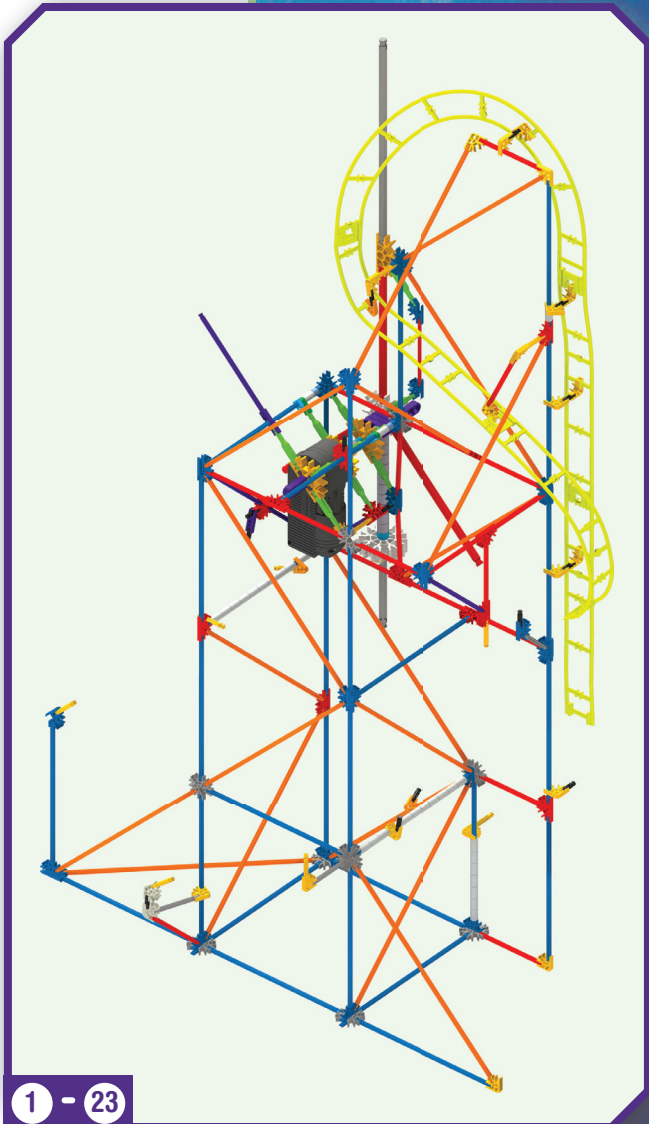

1 - 23



24

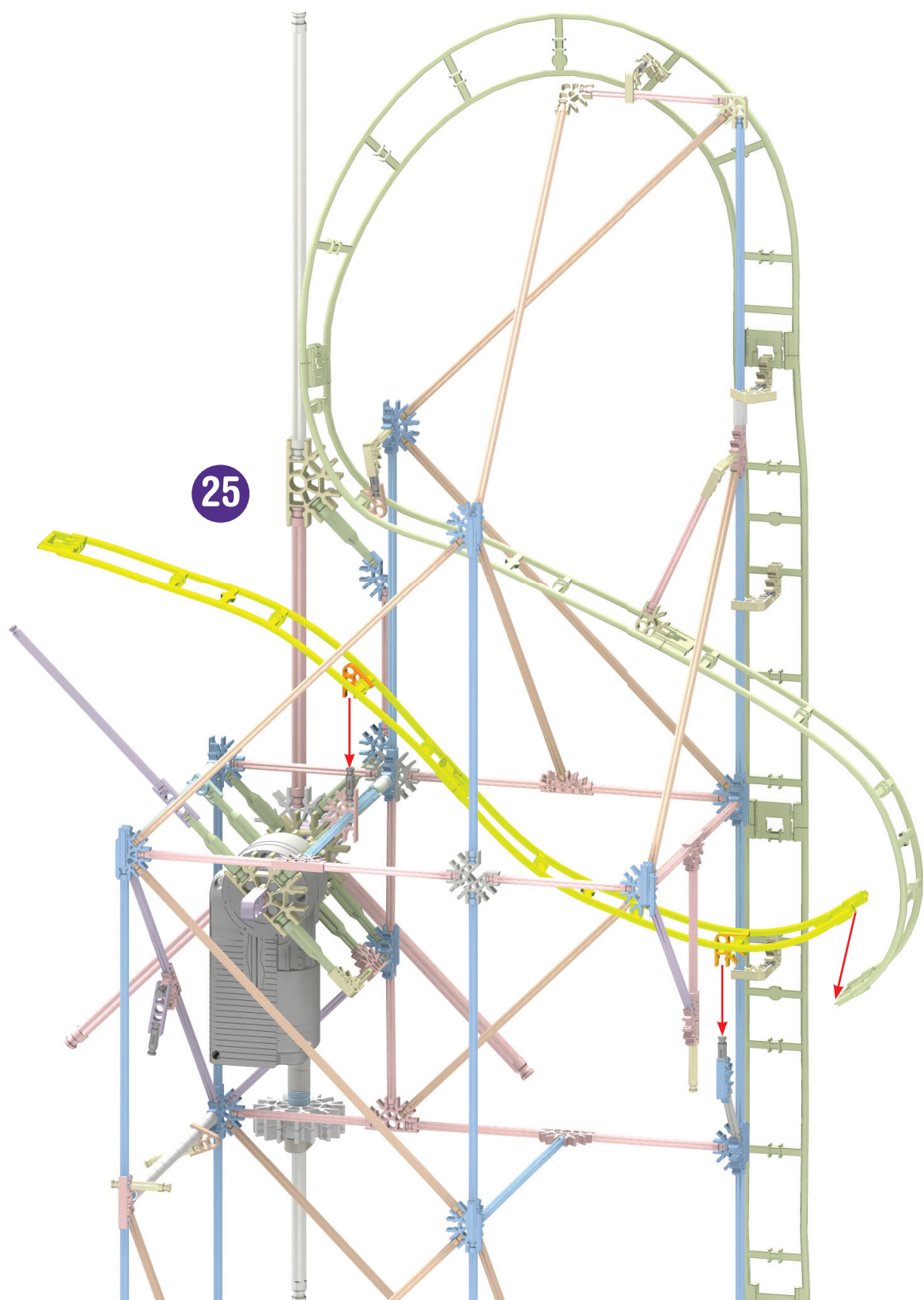

25



1 - 25

26

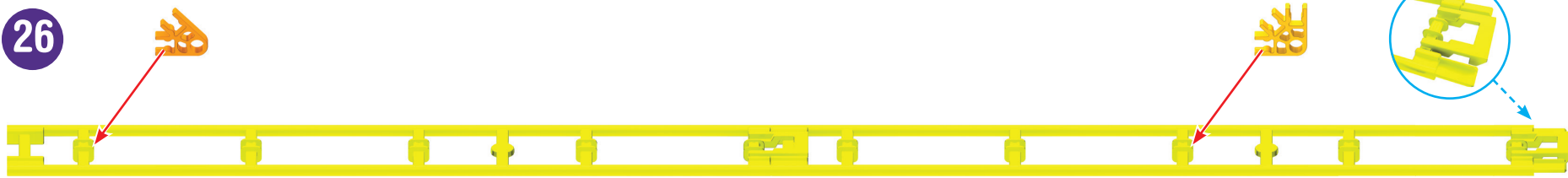

27

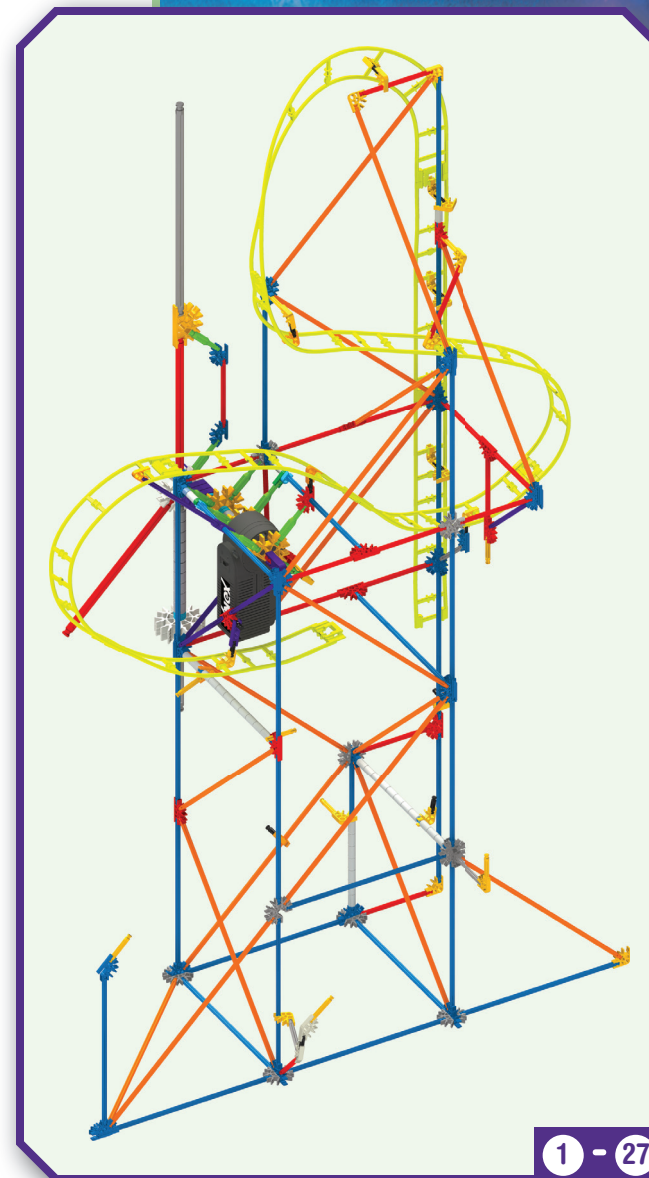
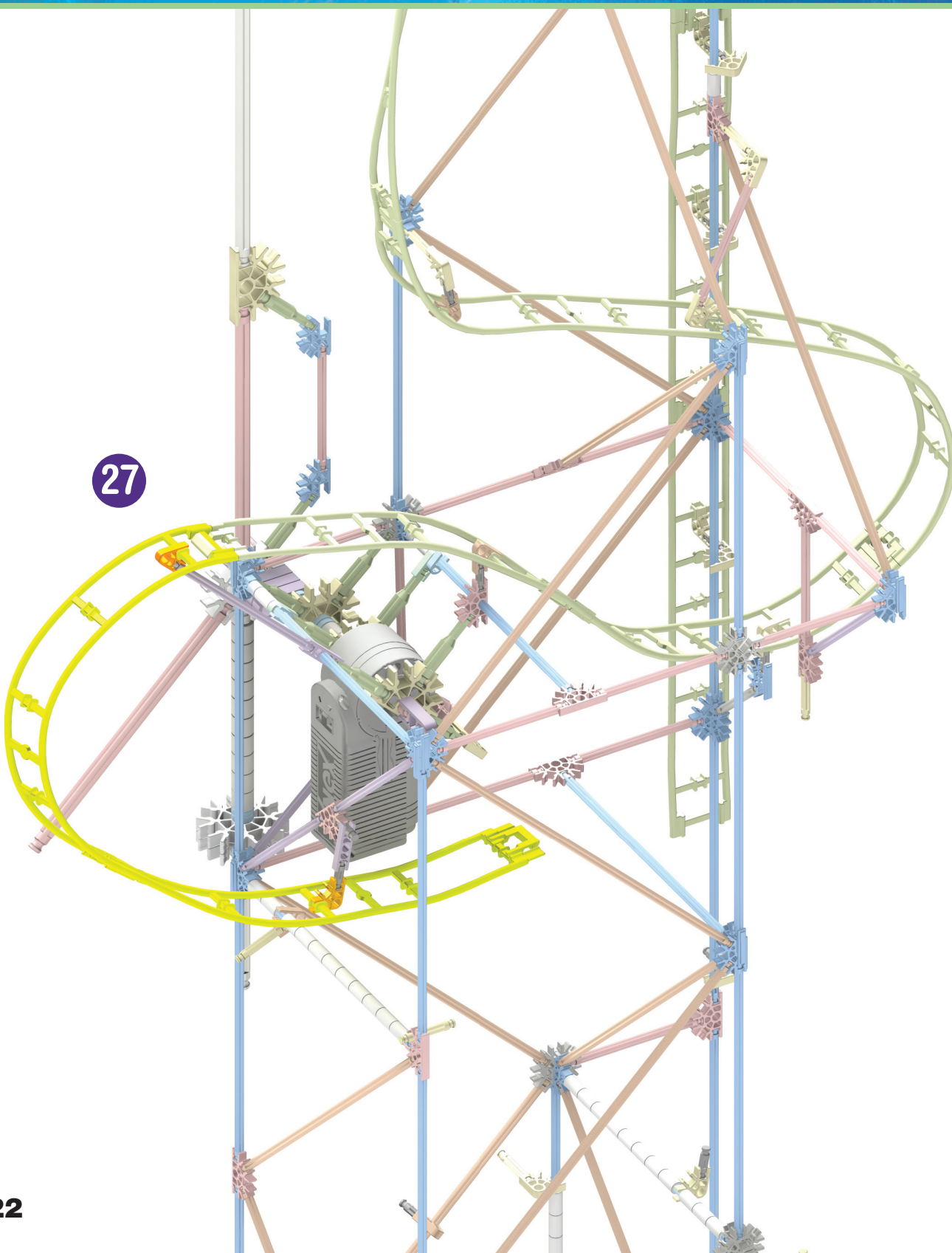

1 - 27

28

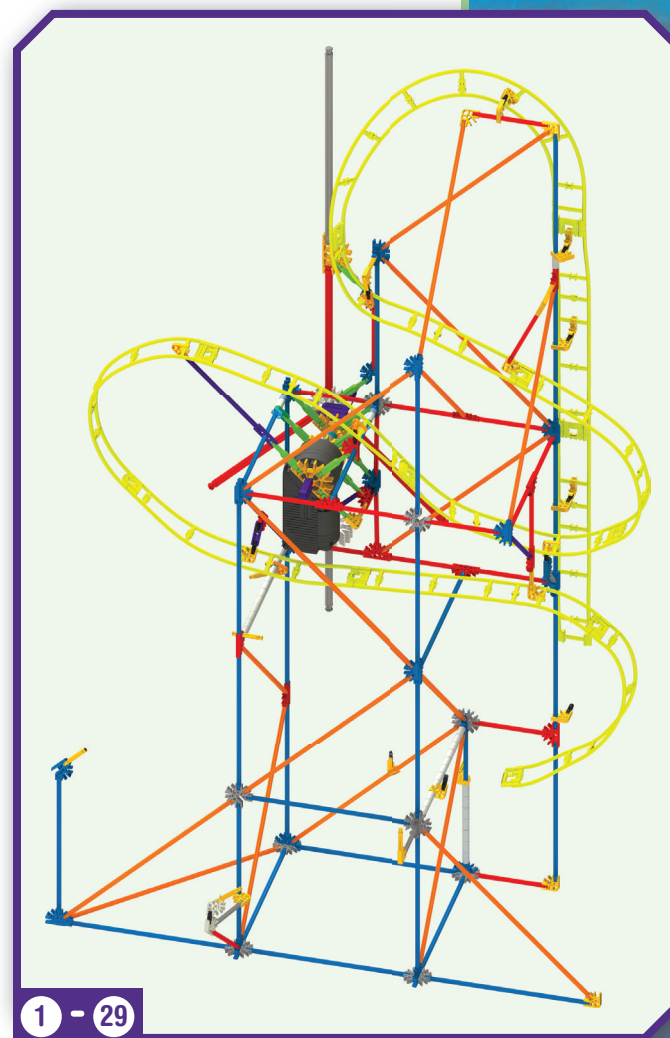

29

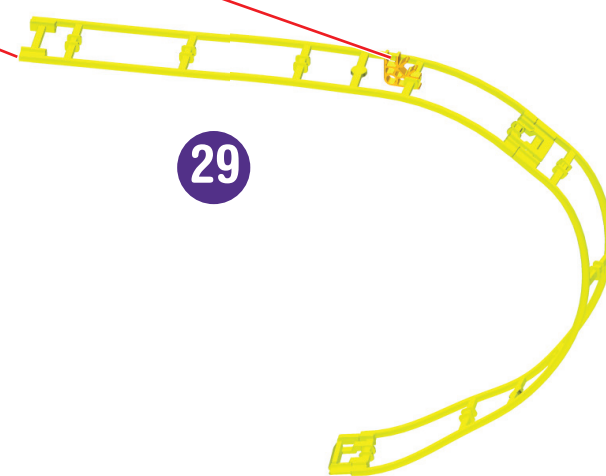

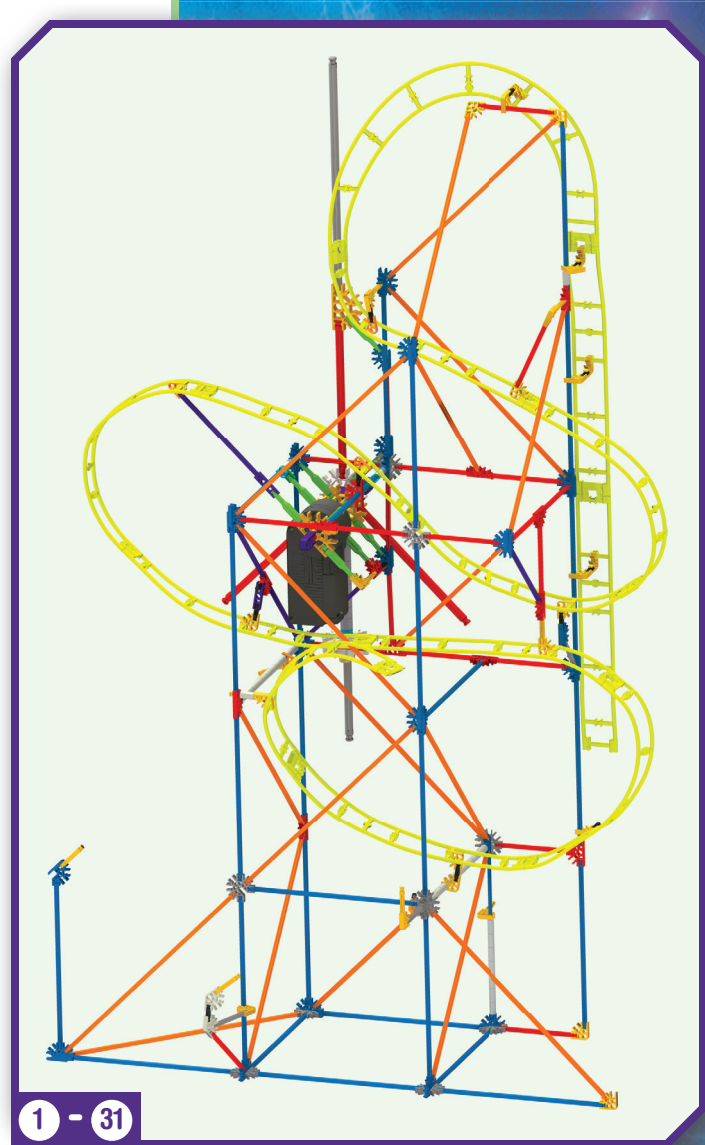
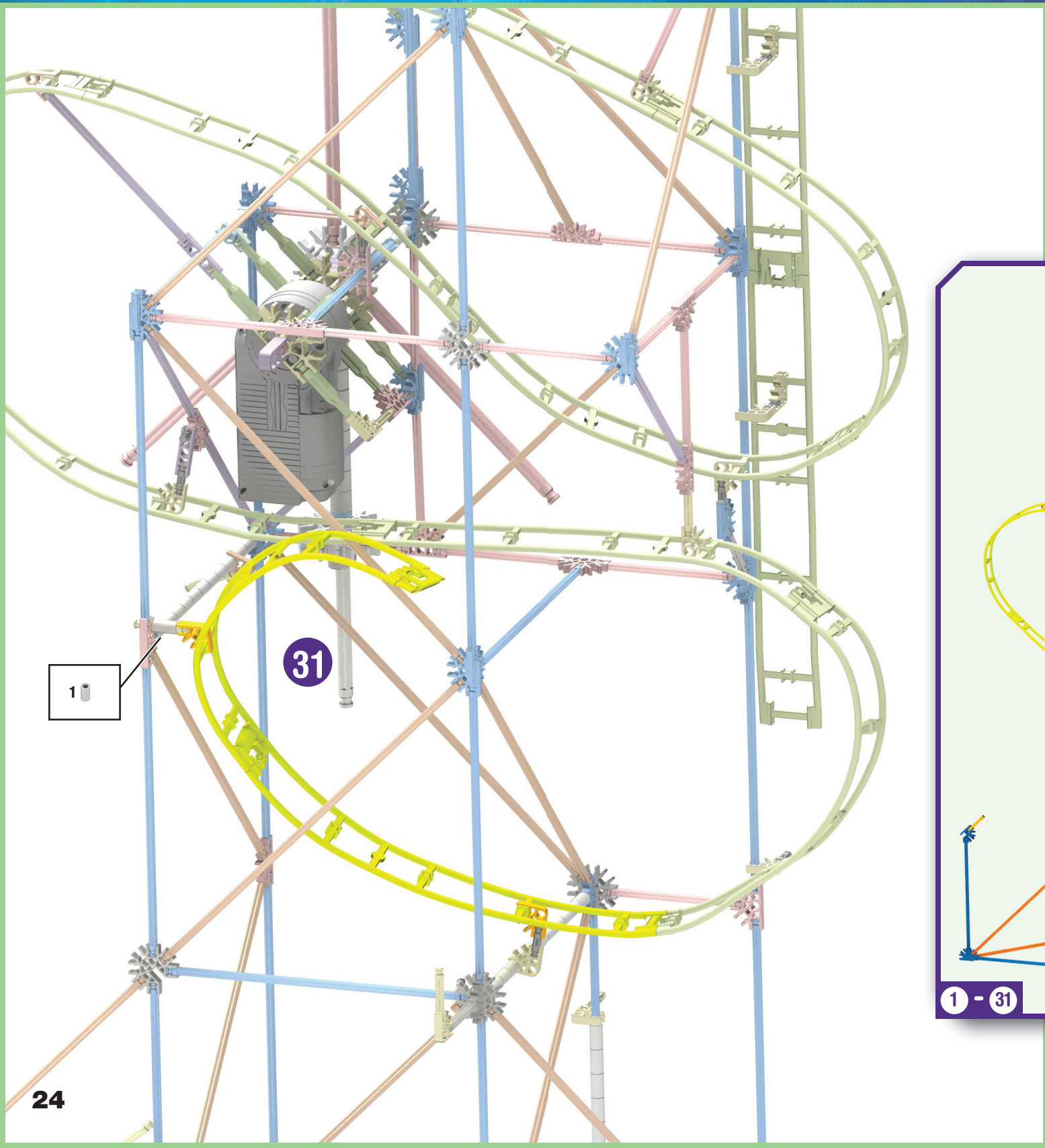
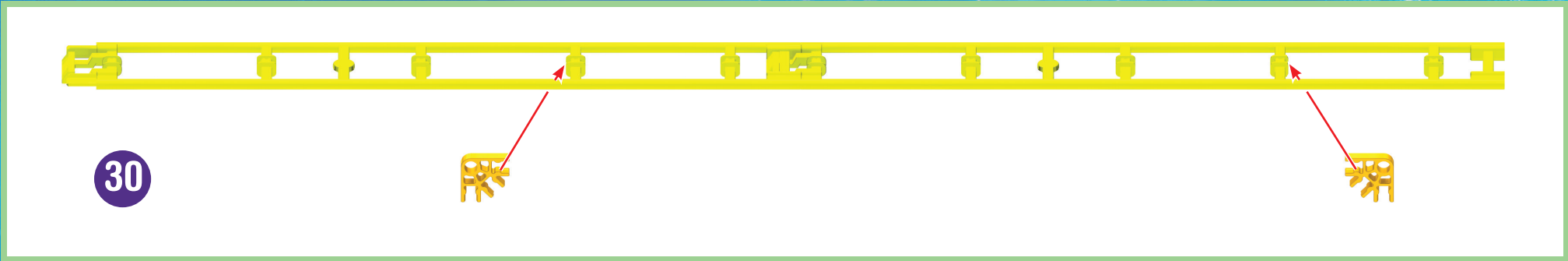

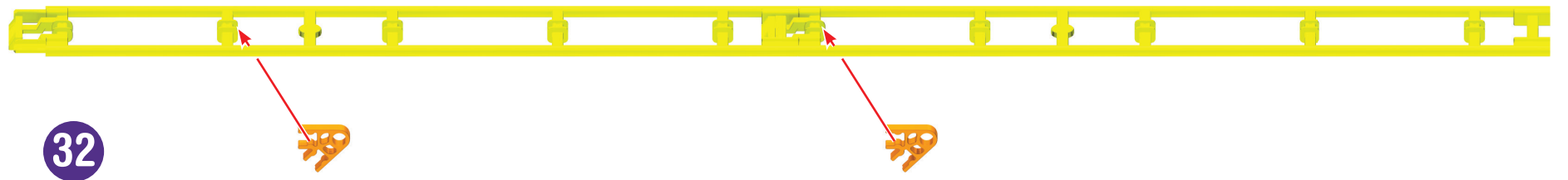

32

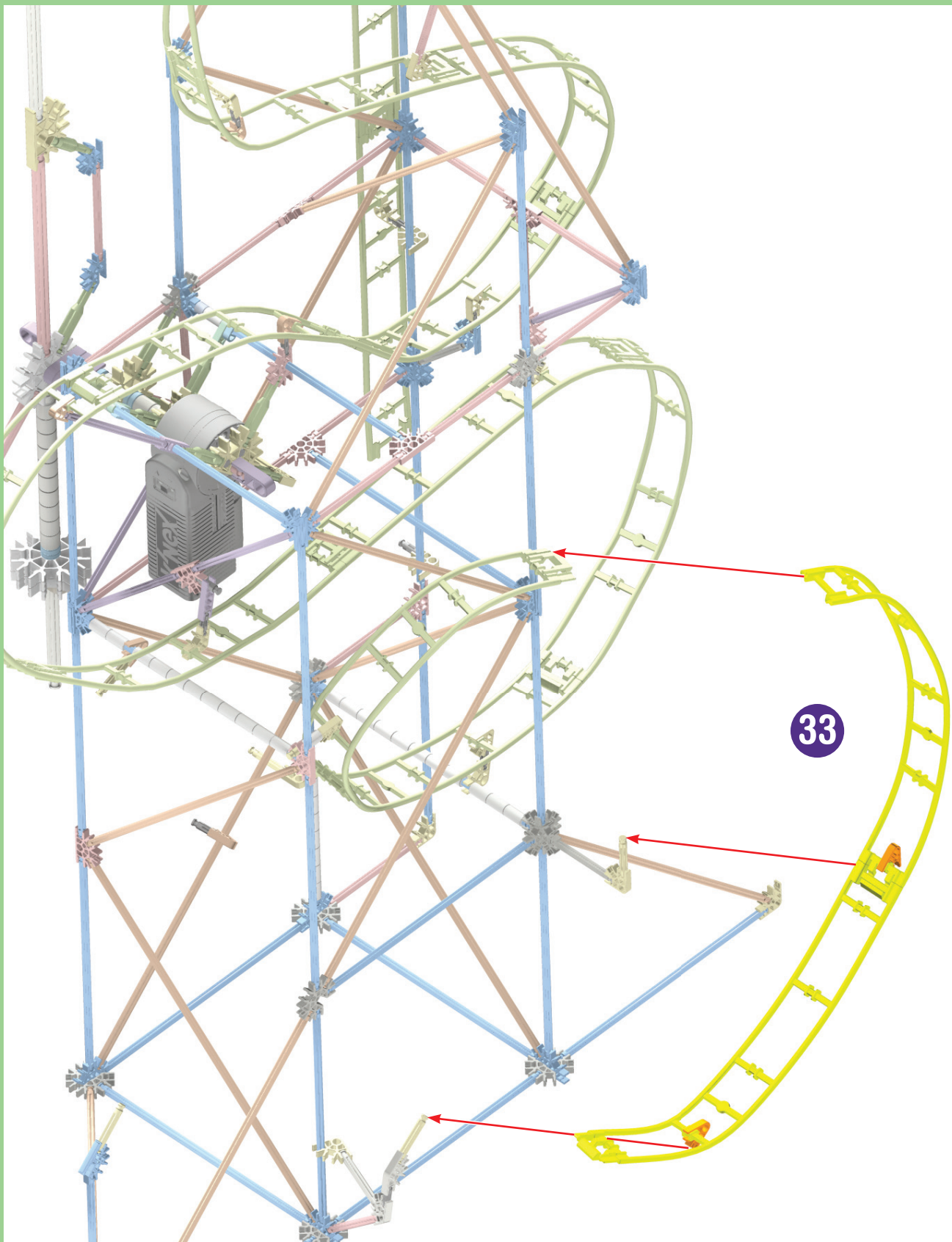

33

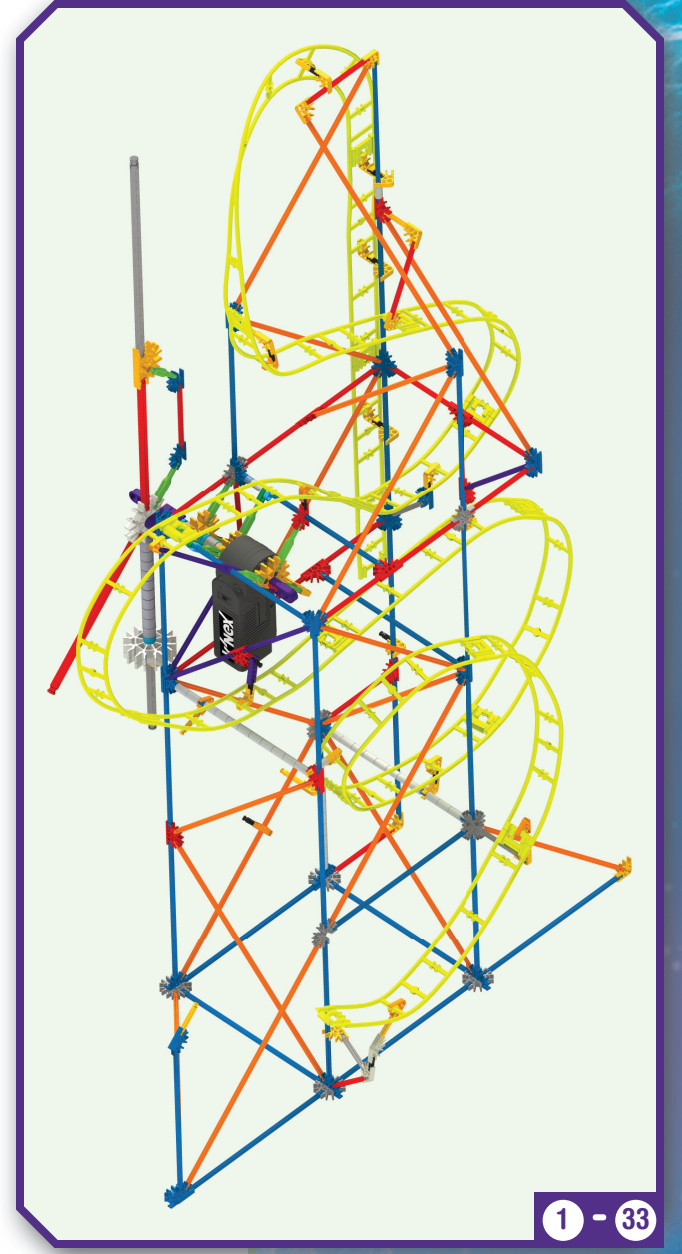

1 - 33

34

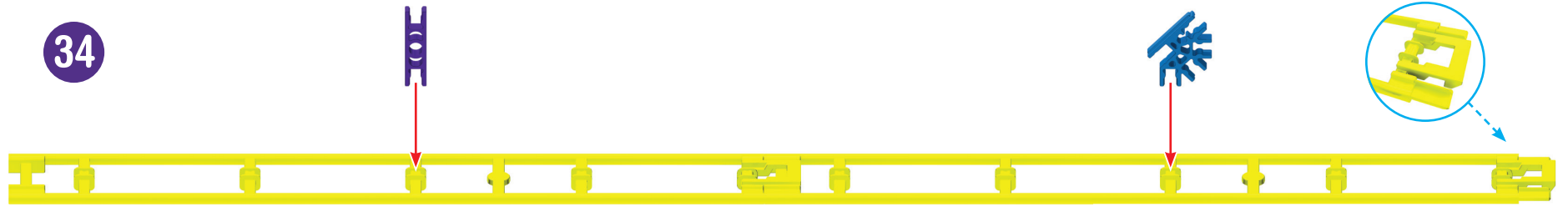

36

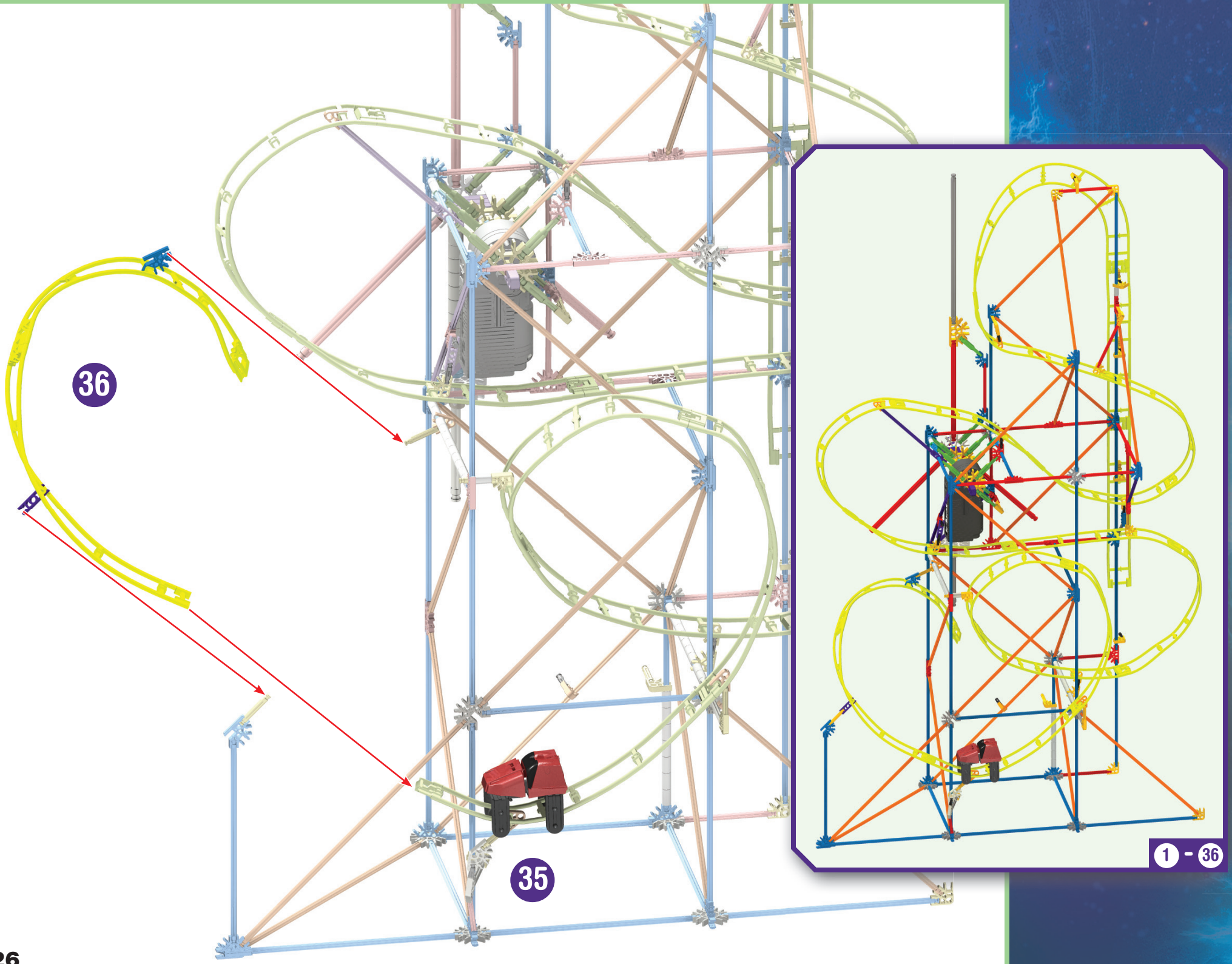

35

1 - 36

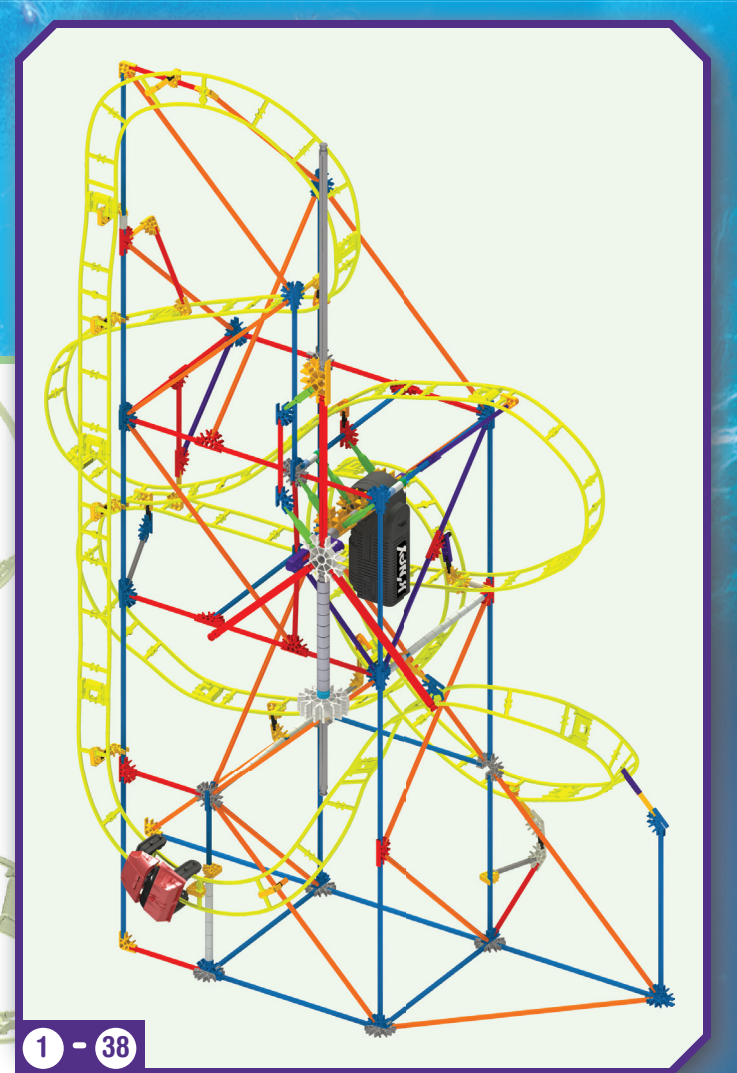
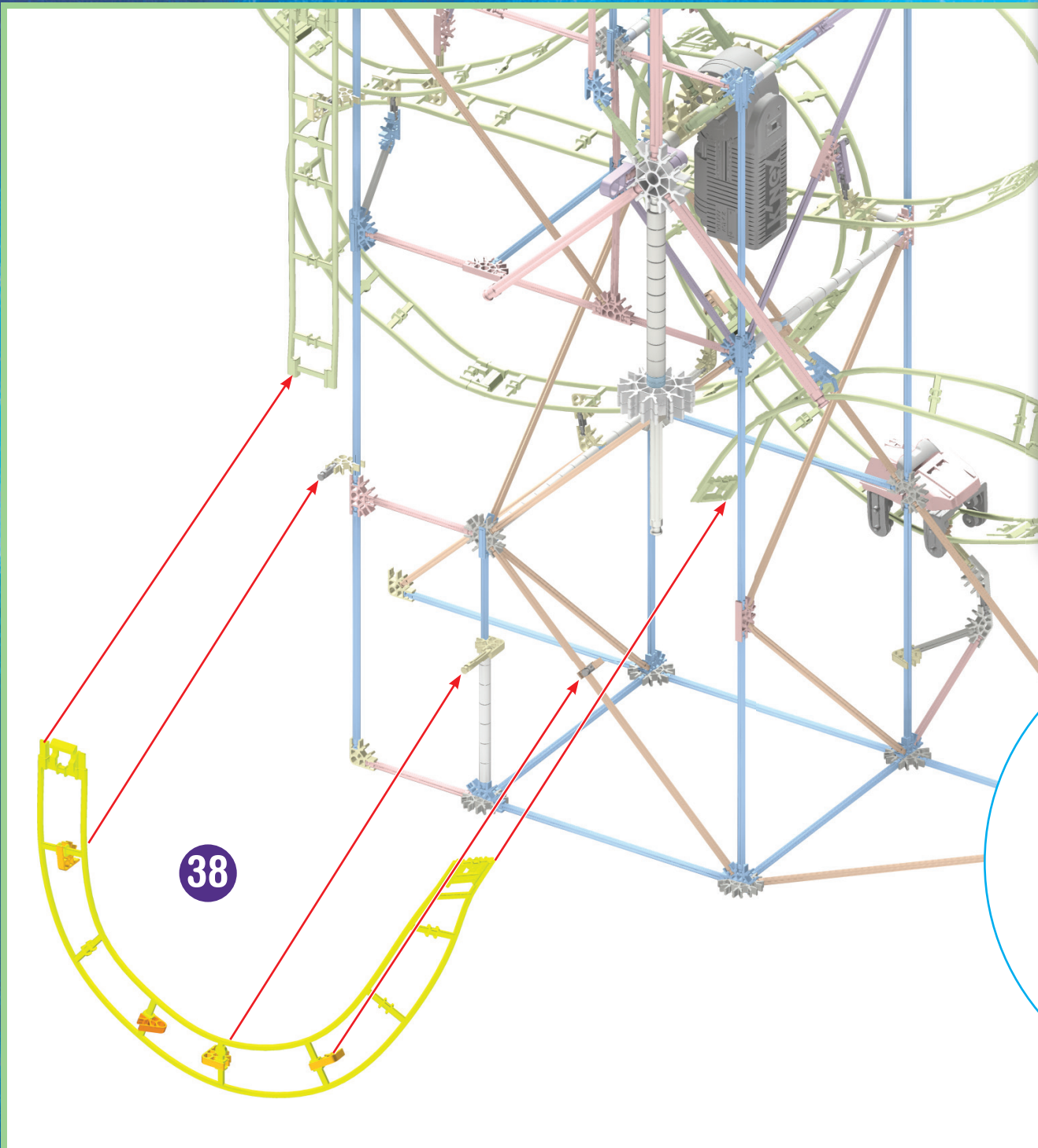
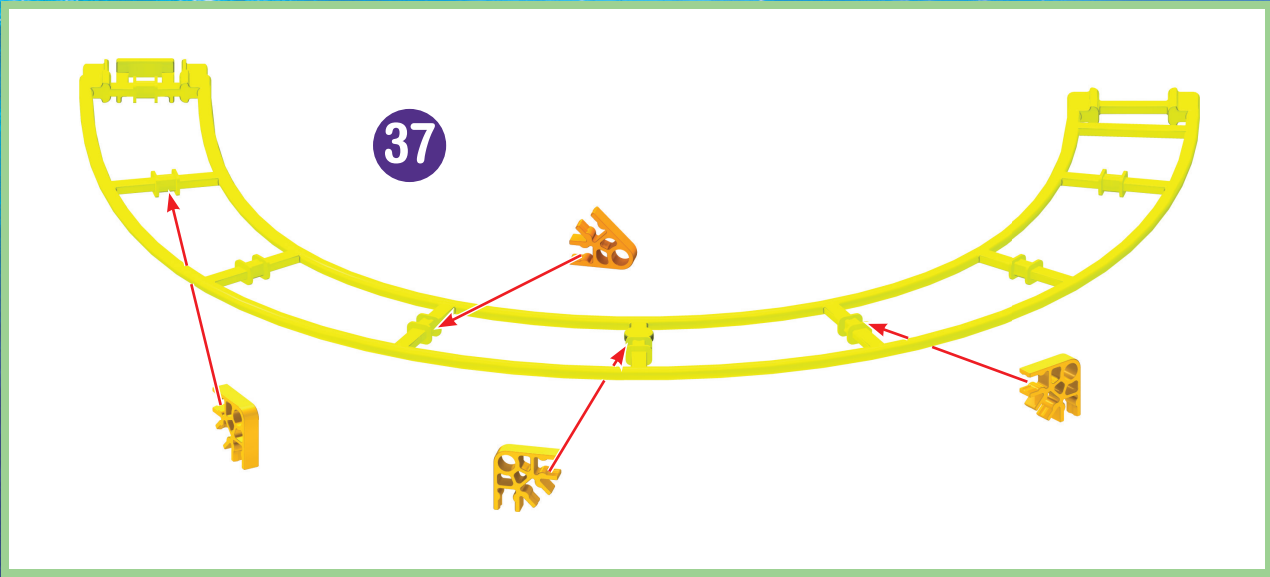

CLOCK WORK
MONTAÑA RUSA
SET DE CONSTRUCCIÓN

CLOCK WORK
MONTANHA RUSSA
SET DE CONSTRUÇÃO

CLOCK WORK
ROLLER COASTER
BUILDING SET

HORLOGIE
MONTAGNES RUSSES
JEU DE CONSTRUCTION



KNEX.COM



REVOLUTION
NORIA
SET DE CONSTRUCCIÓN

REVOLUTION
RODA GIGANTE
SET DE CONSTRUÇÃO

REVOLUTION
FERRIS WHEEL
BUILDING SET

RÉVOLUTION
GRANDE ROUE
JEU DE CONSTRUCTION

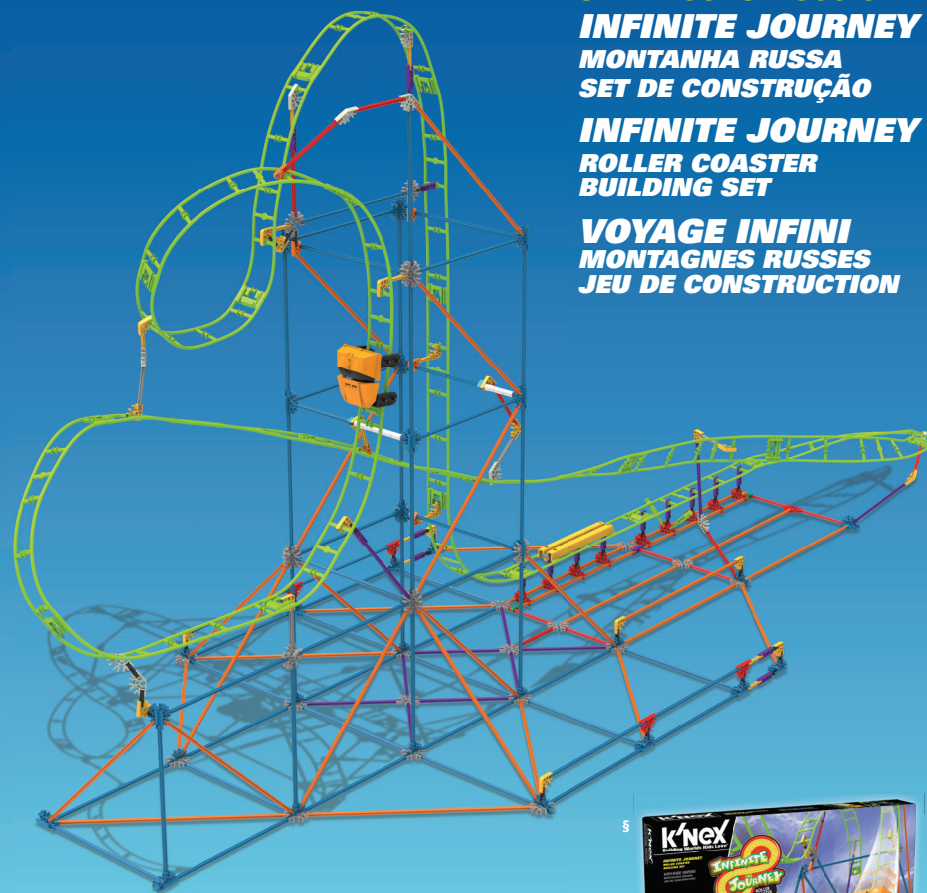

INFINITE JOURNEY
MONTAÑA RUSA
SET DE CONSTRUCCIÓN

INFINITE JOURNEY
MONTANHA RUSSA
SET DE CONSTRUÇÃO

INFINITE JOURNEY
ROLLER COASTER
BUILDING SET

VOYAGE INFINI
MONTAGNES RUSSES
JEU DE CONSTRUCTION



[§] Se venden por separado.
 Vendidos separadamente.
 Sold separately.
 Vendus séparément.

facebook.com/knex @knexbrands

www.fabricajuguetes.com

©2016 K'NEX Limited Partnership Group, P.O. Box 700, Hatfield, PA 19440-0700;
 1-800-KID-KNEX (USA/Canada/États-Unis/EE.UU.); email@knex.com; knex.com.
 K'NEX UK Ltd., P.O. Box 3083, Reading RG1 9YQ, England. For customers outside
 the USA/Canada please contact your local distributor at www.knex.com/distributors.

(ES) Para clientes fuera de EE.UU./Canadá póngase en contacto con el distribuidor local. Encuentre la información para el distribuidor local en www.knex.com/distributors

(PT) Para clientes fora de EUA/Canadá entre em contato com o distribuidor local. Encontrar informações para distribuidor local em www.knex.com/distributors

(FR) Pour les clients en dehors du Canada et des États-Unis, veuillez contacter votre distributeur local que vous pouvez trouver sur www.knex.com/distributors

(ES) K'NEX y Building Worlds Kids Love son marcas registradas de K'NEX Limited Partnership Group.
 (PT) K'NEX e Building Worlds Kids Love são marcas registradas da K'NEX Limited Partnership Group.
 (EN) K'NEX and Building Worlds Kids Love are registered trademarks of K'NEX Limited Partnership Group.
 (FR) K'NEX et Building Worlds Kids Love sont des marques déposées de K'NEX Limited Partnership Group.

(ES) El producto y los colores pueden variar. La mayoría de los modelos se pueden construir uno a la vez.
 (PT) O produto e as cores podem variar. A maioria dos modelos pode ser montado um de cada vez.
 (EN) Product & colors may vary. Most models can be built one at a time.
 (FR) Le produit et ses couleurs peuvent varier. Les différents modèles ne peuvent être construits qu'un par un.

Ensamblado y Distribuido por: / Montado e Distribuído por:
 Assembled and distributed by: / Assemblé et distribué par:

Fábrica de Juguetes S.L.U.
 Avd. del Jugete s/n · apdo.125
 03440 IBI (Alicante) SPAIN

Guarde esta información para futuras referencias.
 Guardar esta informação para futuras referências.
 Save this information for future reference.
 Conservez ces informations à titre de référence.

Ref. 41210 - 15406 NC899/04/41210