



MARIOKART™ Wii

6+

MARIO™ AND DONKEY KONG™ CIRCUIT START LINE BUILDING SET™



MARIOKART

2 Motorized Karts
Karts Motorizado
Karts Motorisé



38350

K'NEX®

EN CAUTION: To Avoid Battery Leakage - Be sure to insert the batteries correctly and always follow the toy and battery manufacturers' instructions. • Do not mix old and new batteries or alkaline, standard (carbon-zinc) or rechargeable (nickel-cadmium) batteries. Only batteries of the same or equivalent type recommended should be used. • Always remove weak or dead batteries from the product; do not short-circuit supply terminals. • Insert batteries with correct polarity (+/-) as shown. **Important Tips:** Alkaline batteries AAA (LR03) are recommended. • Rechargeable batteries are not recommended. • Remove rechargeable batteries from toy before charging; they must be charged only under adult supervision. • Non-rechargeable batteries must not be recharged. • Keep components free of dust; do not immerse or use in water. • Do not dispose of batteries in a fire; they could leak or explode and cause injury. • Remove all batteries if the toy will not be used for a long period of time. **CAUTION:** Keep hands, face, hair and clothing away from all moving parts.

CAUTION: Rubber Bands can cause injury from snap-back, breaking, or loss of control. While assembling models shown in instructions, hold rubber band tightly, and do not overstretch. Use Rubber Bands only as shown in these instructions. **DO NOT USE FRAYED OR TORN RUBBER BANDS. CAUTION:** Keep Rubber Bands away from face and eyes.

ES PRECAUCIÓN: Para evitar pérdidas en las pilas - Asegúrese de que instala las pilas correctamente y de que siempre sigue las instrucciones del fabricante del juguete y del fabricante de las pilas. • No mezcle pilas viejas con nuevas, ni mezcle pilas alcalinas, estándar (de carbón - cinc) o recargables (de níquel - cadmio). Use sólo pilas del tipo recomendado o equivalentes a éstas. • Siempre retire las pilas muy gastadas o acabadas del producto y no permita que se formen cortocircuitos en los bornes. Inserte las pilas, asegurándose de que la polaridad sea la correcta (+/-), tal como se muestra. **Importantes Consejos:** Se recomiendan pilas alcalinas AAA (LR03). • No se recomiendan las pilas recargables. • Retire las pilas recargables del juguete antes de volverlas a cargar. Las pilas deben ser recargadas sólo bajo la supervisión de un adulto. • Pilas no recargables no deben ser recargadas. • Mantenga todos los elementos libres de polvo, no los sumerja o use en agua. • No quemé las pilas en un fuego, ya que pueden tener pérdidas o explotar, causando lesiones. • Retire todas las pilas del juguete si éste no va a ser usado por un largo período de tiempo. **PRECAUCIÓN:** Guardar las manos, la cara, el pelo y la ropa lejos de todas las piezas móviles.

PRECAUCIÓN: Las gomas pueden causar daños si se sueltan con fuerza, se rompen o se pierde su control. Al construir los modelos que se muestran en las instrucciones, sujetar bien la goma y no estirarla demasiado. Las gomas deben usarse únicamente como se indica en las instrucciones. **NO USAR GOMAS QUE ESTÉN DESGASTADAS NI ASGADAS. PRECAUCIÓN:** Mantenga las gomas elásticas alejadas de la cara y los ojos.

FR ATTENTION : Pour éviter que les piles ne fuient - Veillez à introduire les piles correctement et suivez toujours les instructions des fabricants du jouet et des piles. • Ne mélangez pas des piles usées et des piles neuves ou des piles alcalines, standard (carbone/zinc) ou rechargeables (cadmium-nickel). Il est important de n'utiliser que des piles du même type ou équivalent recommandé. • Retirez toujours les piles faibles ou mortes du produit ; ne faites pas court-circuiter les points d'échange. • Introduisez les piles en respectant la polarité (+/-) comme l'indique le schéma. **Conseils importants :** Des piles alcalines AAA (LR03) sont recommandées. • Les piles rechargeables ne sont pas recommandées. • Retirez les piles rechargeables du jouet avant de les faire recharger ; elles ne doivent être rechargées que sous la surveillance d'un adulte. • Les piles qui ne sont pas rechargeables ne doivent pas être rechargées. • Gardez les éléments

à l'abri de la poussière, ne les plonge pas dans l'eau, ne les utilisez pas dans l'eau. • Ne jetez pas les piles dans un feu ; elles risqueraient de fuir ou d'exploser et d'entraîner des blessures. • Retirez toutes les piles si le jouet ne doit pas être utilisé pendant une longue période. **ATTENTION :** Garder les mains, le visage, les cheveux et l'habillement à partir de toutes les pièces mobiles.

ATTENTION : Les élastiques peuvent causer des blessures en claquant, en se cassant ou quand on les manipule imprudemment. Tenez fermement l'élastique lors de l'assemblage du modèle en veillant à ne pas trop le tendre. N'utilisez les élastiques que selon les instructions. **N'UTILISEZ PAS D'ÉLASTIQUES ÉRAILLÉS OU DÉCHIRÉS. ATTENTION :** Tenez les élastiques en caoutchouc à l'écart du visage et des yeux.

DE VORSICHT: Vermeidung von auslaufenden Batterien - Achten Sie darauf, die Batterien richtig einzulegen. Beachten Sie grundsätzlich die Hinweise von Spielzeug- und Batteriehersteller. • Alte und neue Batterien sowie Alkali-, Standard- (Kohle-Zink) oder wiederaufladbare Batterien (Nickel-Cadmium) nicht miteinander mischen. Es sollten nur Batterien des empfohlenen oder diesem ähnlichen Typs verwendet werden. • Fast oder völlig leere Batterien grundsätzlich aus dem Produkt entfernen; die Anschlussklemmen nicht kurzschließen. • Beim Einlegen der Batterie auf richtige Polarität achten (+/-), wie in der Abbildung. **Wichtige Tipps:** Wir empfehlen Alkalibatterien AAA (LR03). • Wiederaufladbare Batterien werden nicht empfohlen. • Wiederaufladbare Batterien vor dem Laden aus dem Spielzeug entfernen. Diese dürfen nur unter Aufsicht eines Erwachsenen aufgeladen werden. • Einwegbatterien dürfen nicht wieder aufgeladen werden. • Die einzelnen Teile von Schmutz und Staub fernhalten. Nicht in Wasser tauchen und nicht im Wasser verwenden. • Batterien nicht in offene Flammen werfen; sie könnten auslaufen oder explodieren und zu Verletzungen führen. • Falls das Spielzeug längere Zeit nicht benutzt wird, alle Batterien entfernen. **VORSICHT:** Hände, Gesicht, Haar und Kleidung weg von allen beweglichen Teilen halten.

VORSICHT: Gummibänder können Verletzungen hervorrufen, wenn sie reißen, zurückspringen oder wenn sie nicht vorsichtig gehandhabt werden. Halten Sie die Gummibänder während des Zusammenbaus der Modelle fest, ohne sie jedoch zu überdehnen. Verwenden Sie die Gummibänder gemäß den Anweisungen. **VERWENDEN SIE NIEMALS AUSGEFRANSTE ODER ZERRISSENE GUMMIBÄNDER. VORSICHT:** Halten Sie Gummibänder weg von Gesicht und Augen.

IT ATTENZIONE: Per evitare perdite dalle batterie - Accertarsi di inserire le batterie correttamente e di seguire sempre le istruzioni del produttore delle batterie e del giocattolo. • Non mettere insieme batterie nuove e vecchie o batterie alcaline, standard (zinco-carbonio) e ricaricabili (nichel-cadmio). Usare soltanto batterie dello stesso tipo o tipo equivalente, come raccomandato. • Togliere sempre le batterie quasi o completamente scariche dal prodotto, non mettere in corto circuito i terminali di alimentazione. • Inserire le batterie con la corretta polarità (+/-) come mostrato. **Suggerimenti importanti:** Si consiglia di usare batterie alcaline AAA (LR03). • Si consiglia di non usare batterie ricaricabili. • Rimuovere le batterie ricaricabili dal giocattolo prima di caricarle: devono essere caricate soltanto sotto la supervisione di un adulto. • Le batterie non ricaricabili non devono essere ricaricate. • Mantenere i componenti privi di polvere, non immergerli e non usarli dentro l'acqua. • Non gettare le batterie nel fuoco in quanto potrebbero perdere o esplodere e causare lesioni. • Rimuovere tutte le batterie se il giocattolo non viene usato per un lungo periodo di tempo. **ATTENZIONE:** Mantenere le mani, il viso, i capelli ed i vestiti a partire da tutti i pezzi mobili.

ATTENZIONE: Elastici può causare lesioni da snap-back, rottura, o perdita di controllo. Durante il montaggio dei modelli indicati nelle istruzioni, tenere ben elastico, e non tirare troppo. Utilizzare Elastici solo come indicato in queste istruzioni. **NON USARE SFILACCIATI O STRAPPATI ELASTICI. ATTENZIONE:** Mantenga gli elastici a partire dal fronte e dagli occhi.

PT CUIDADO: Como evitar fugas das pilhas - Certifiquem-se de que introduzem as pilhas correctamente seguindo sempre as instruções do fabricante do brinquedo e das pilhas. • Nunca combinem pilhas usadas com pilhas novas ou pilhas alcalinas, padrão (carvão-zinco) ou pilhas recarregáveis (níquel-cádmio). Devem ser utilizadas apenas pilhas do mesmo tipo ou de tipo equivalente recomendado. • Retirem sempre as baterias fracas ou esgotadas do produto; não provoquem um curto-circuito nos terminais de alimentação. • As pilhas devem ser introduzidas com a polaridade correcta (+/-), conforme mostrado. **Sugestões importantes:** Recomendamos o uso de pilhas alcalinas AAA (LR03). • Não recomendamos o uso de pilhas recarregáveis. • Devem retirar as pilhas recarregáveis do brinquedo antes de procederem à respectiva recarga; estas pilhas devem ser recarregadas apenas sob supervisão de adultos. • Não se deve tentar carregar pilhas não recarregáveis. • Os componentes devem ser mantidos sem pó; não se devem mergulhar nem usar com água. • Não elimine as pilhas no fogo; estas podem ter fugas ou explodir, causando lesões. • Retirem todas as pilhas do brinquedo se este não for usado durante um longo período de tempo. **CUIDADO:** Manter as mãos, a cara, o cabelo e a roupa longe de todas as peças moventes.

CUIDADO: As borrachas poderão causar ferimentos ao serem esticadas, ao quebrarem ou ao perderem controlo. Ao montar os modelos mostrados nas instruções, segure bem a borracha e não a estique demasiado. Utilize as borrachas apenas da forma exemplificada nestas instruções. **NÃO UTILIZE BORRACHAS CORROÍDAS OU QUEBRADAS. CUIDADO:** Mantenha as faixas de borracha longe da cara e dos olhos.

NL OPGEPAST: Om batterijlekkage te verhinderen - Verzeker je ervan de batterijen correct aan te brengen en volg steeds de instructies van de speelgoed- en batterijenfabrikant. • Meng geen oude en nieuwe batterijen of alkaline, gewone (koolstof-zink) of heroplaadbare (nikkel-cadmium) batterijen. Slechts batterijen van hetzelfde aanbevolen type of een equivalent type dienen gebruikt te worden. • Verwijder altijd zwakke of uitgeputte batterijen uit het product; de toevoeraansluitklemmen niet kortsluiten. • Steek de batterijen erin met de correcte polariteit (+/-) zoals afgebeeld. **Belangrijke Tips:** Alkalische AAA (LR03) batterijen worden aanbevolen. • Heroplaadbare batterijen worden niet aanbevolen. • Verwijder de heroplaadbare batterijen uit het speelgoed alvorens op te laden; ze moeten uitsluitend worden opgeladen onder toezicht van een volwassene. • Niet-heroplaadbare batterijen mogen niet heropgeladen worden. • Hou de bestanddelen vrij van stof; dompel ze niet of gebruik ze niet in water. • Werp de batterijen niet weg in het vuur; ze zouden kunnen lekken of ontploffen en verwondingen veroorzaken. • Verwijder alle batterijen indien het speelgoed gedurende een lange periode niet zal gebruikt worden. **OPGEPAST:** Houd handen, gezicht, haar en kleding vanaf alle bewegende delen.

OPGEPAST: Gummibånd kan forårsage personskade, hvis de springer tilbage, går i stykker eller springer af. Når modellerne samles efter instruktionerne, skal man holde gummibåndene stramme, men ikke strække dem for meget. Gummibåndene må kun bruges, som anvist. **BRUG ALDRIG SLIDTE ELLER BESKADIGEDE GUMMIBÅND. OPGEPAST:** Houd elastiekjes vanaf gezicht en ogen.



MARIO KART™

Wii

1

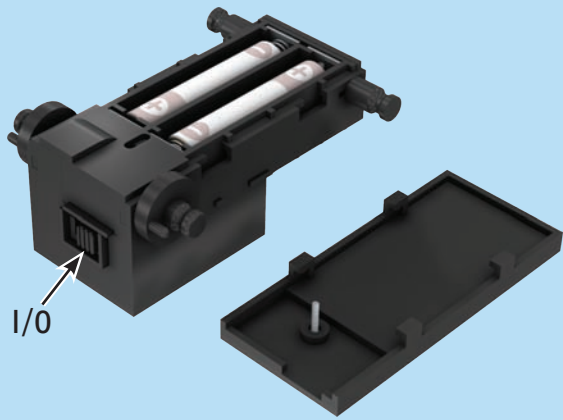

2

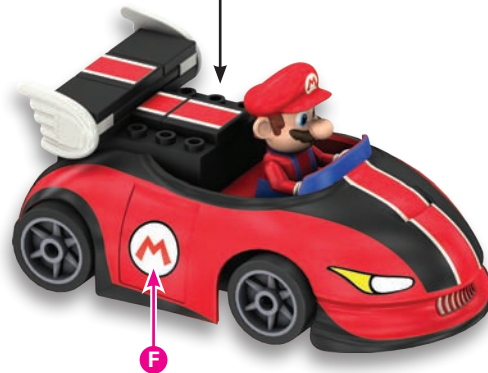
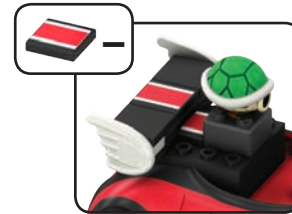
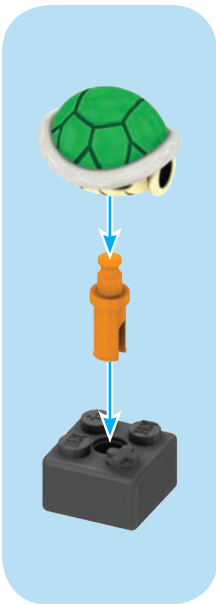
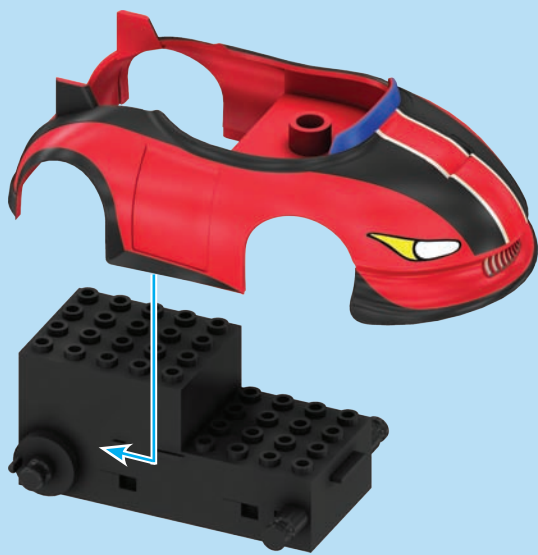

⚠ WARNING: CHOKING HAZARD – SMALL PARTS.
Not for children under 3 years.

⚠ ADVERTENCIA: PELIGRO DE ASFIXIA – PIEZAS PEQUEÑAS. No para niños menores de 3 años.

⚠ ATTENTION ! RISQUE D'ÉTOUFFEMENT – PIÈCES DE PETITE TAILLE. Ne convient pas aux enfants de moins de 3 ans.

⚠ WARNHINWEIS: ERSTICKUNGSGEFAHR – KLEINTEILE. Nicht geeignet für Kinder unter 3 Jahren.

⚠ AVVERTENZA: PERICOLO DI SOFFOCAMENTO – CONTIENE PICCOLE PARTI. Non adatto per bambini al di sotto di 3 anni.

⚠ AVISO: PERIGO DE SUFOCAÇÃO – PEÇAS PEQUENAS. Não se destina a crianças com menos de 3 anos de idade.

⚠ WAARSCHUWING: VERSTIKKINGSGEVAAR – KLEINE ONDERDELEN. Niet geschikt voor kinderen onder 3.

- Apply stickers
- Aplicar pegatinas
- Apposez des autocollants
- Anbringen von Aufklebern
- Applicare gli adesivi
- Aplicar adesivos
- Aanbrengen stickers

3

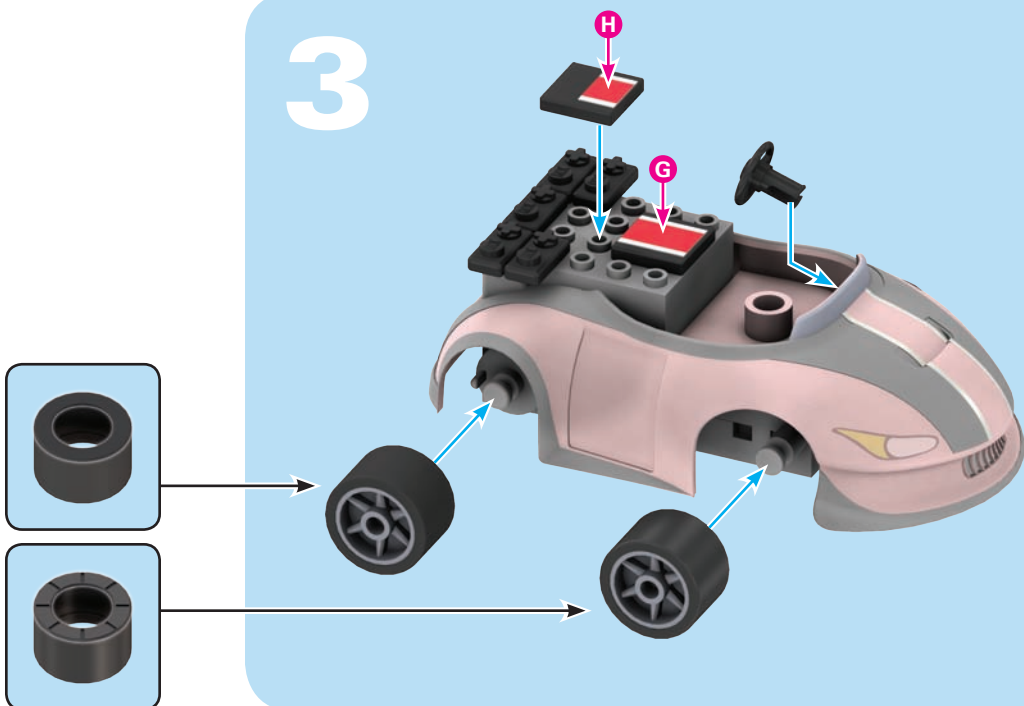

4

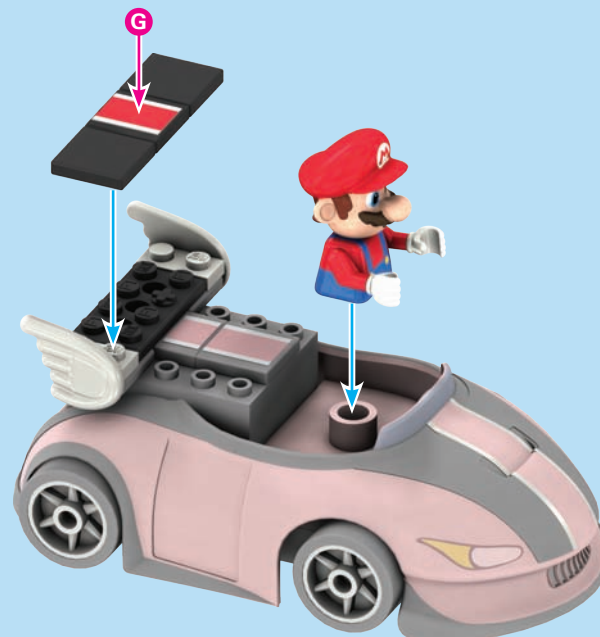

MARIOKART™

Wii

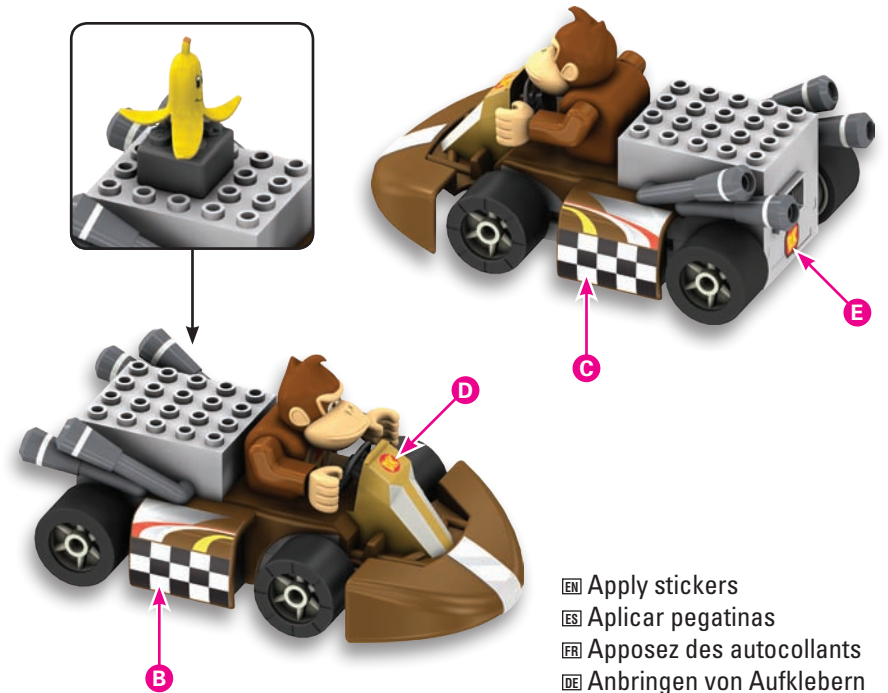
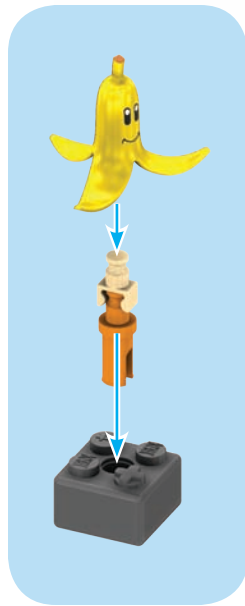
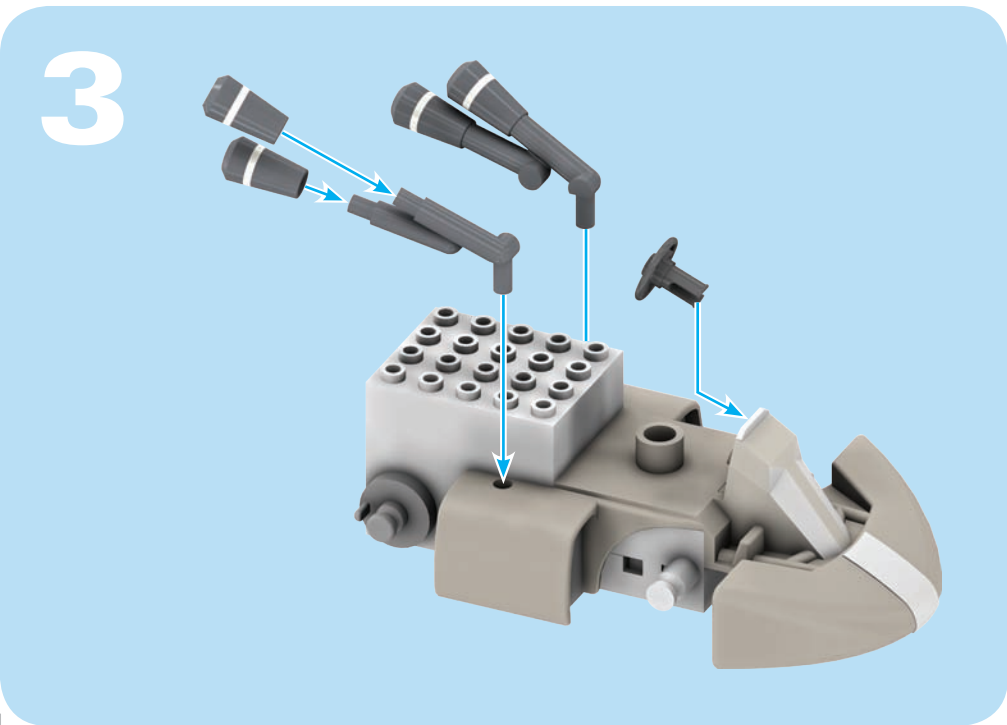
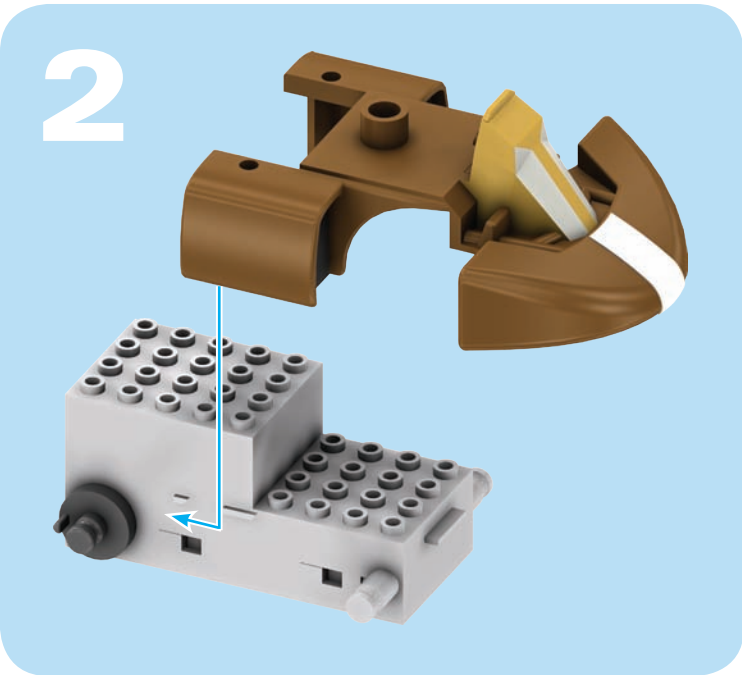
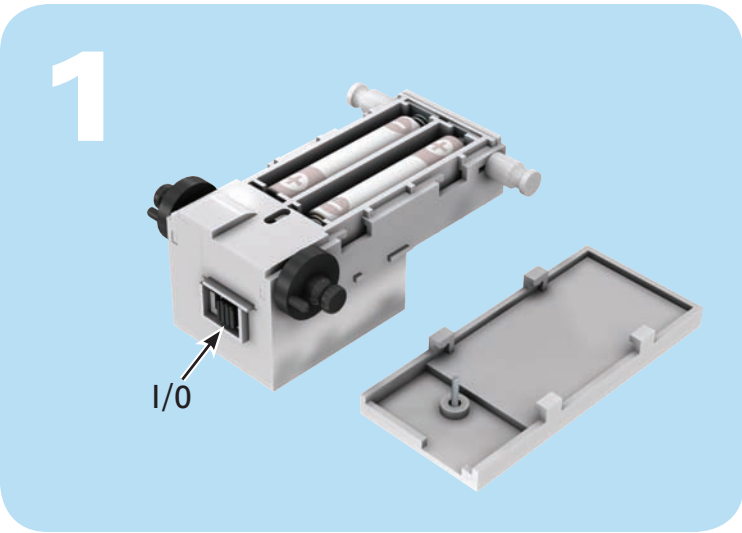

⚠ WARNING: CHOKING HAZARD – SMALL PARTS.
Not for children under 3 years.

⚠ ADVERTENCIA: PELIGRO DE ASFIXIA – PIEZAS PEQUEÑAS. No para niños menores de 3 años.

⚠ ATTENTION ! RISQUE D'ÉTOUFFEMENT – PIÈCES DE PETITE TAILLE. Ne convient pas aux enfants de moins de 3 ans.

⚠ WARNHINWEIS: ERSTICKUNGSGEFAHR – KLEINTEILE. Nicht geeignet für Kinder unter 3 Jahren.

⚠ AVVERTENZA: PERICOLO DI SOFFOCAMENTO – CONTIENE PICCOLE PARTI. Non adatto per bambini al di sotto di 3 anni.

⚠ AVISO: PERIGO DE SUFOCAÇÃO – PEÇAS PEQUENAS. Não se destina a crianças com menos de 3 anos de idade.

⚠ WAARSCHUWING: VERSTIKKINGSGEVAAR – KLEINE ONDERDELEN. Niet geschikt voor kinderen onder 3.

- Apply stickers
- Aplicar pegatinas
- Apposez des autocollants
- Anbringen von Aufklebern
- Applicare gli adesivi
- Aplicar adesivos
- Aanbrengen stickers

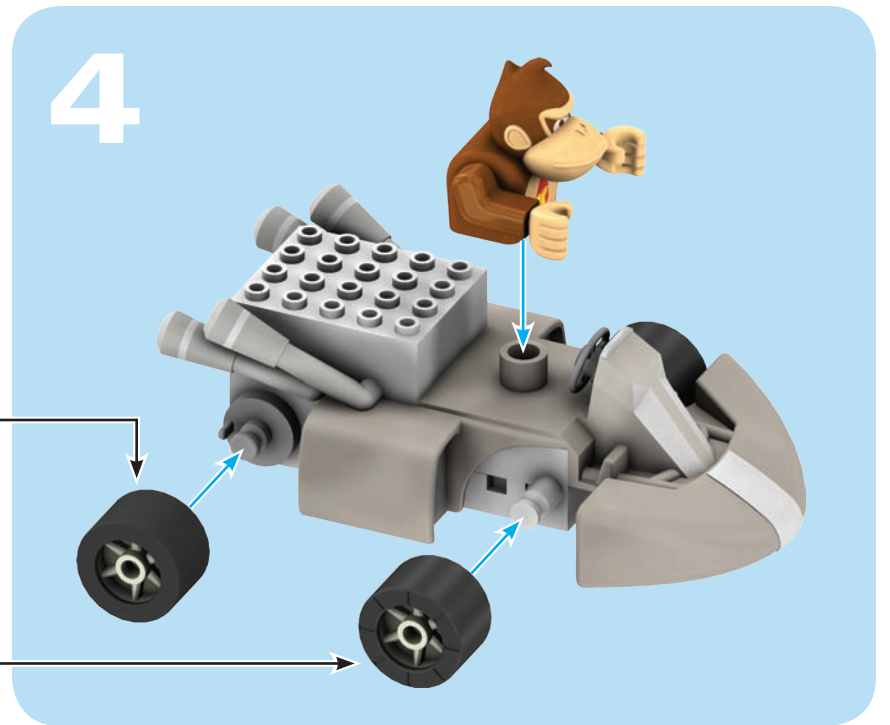

- ☒ Apply stickers
- ☒ Aplicar pegatinas
- ☒ Appezer des autocollants
- ☒ Anbringen von Aufklebern

- ☒ Applicare gli adesivi
- ☒ Aplicar adhesivos
- ☒ Aanbrengen stickers

1

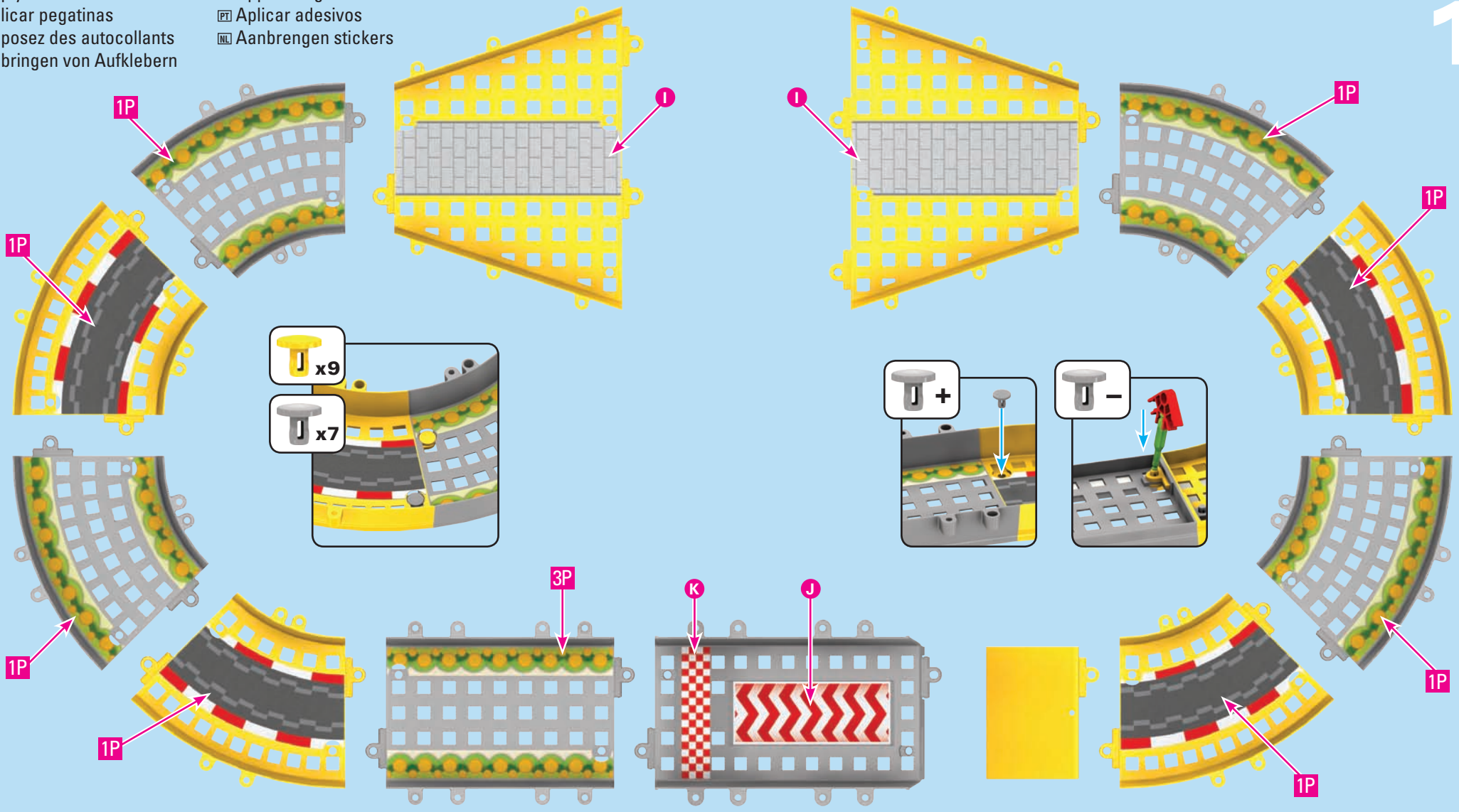

2

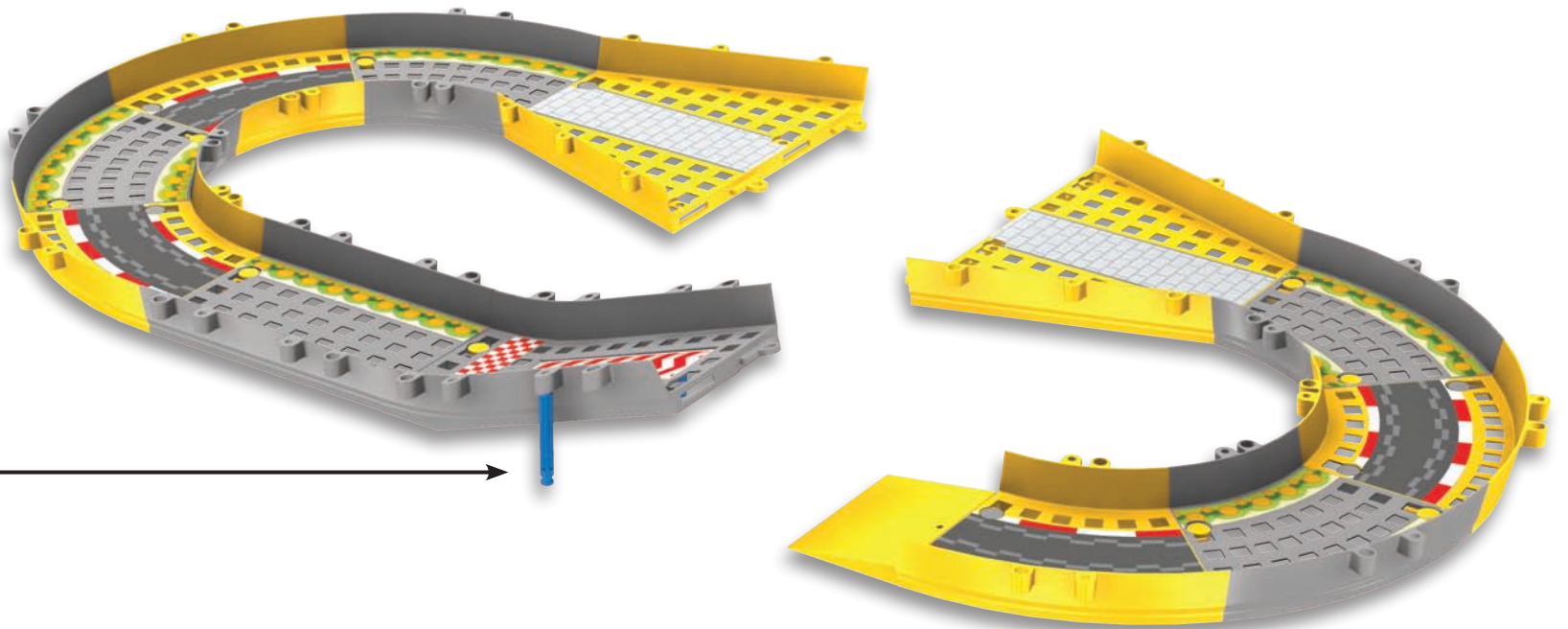

1

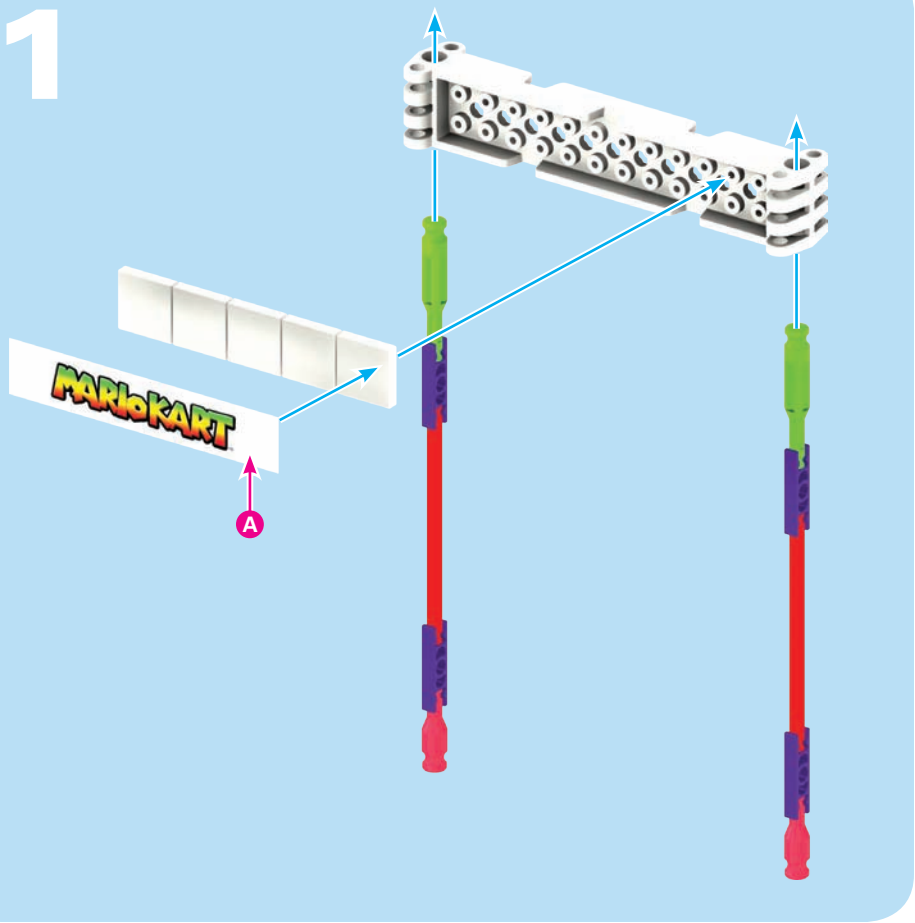

2

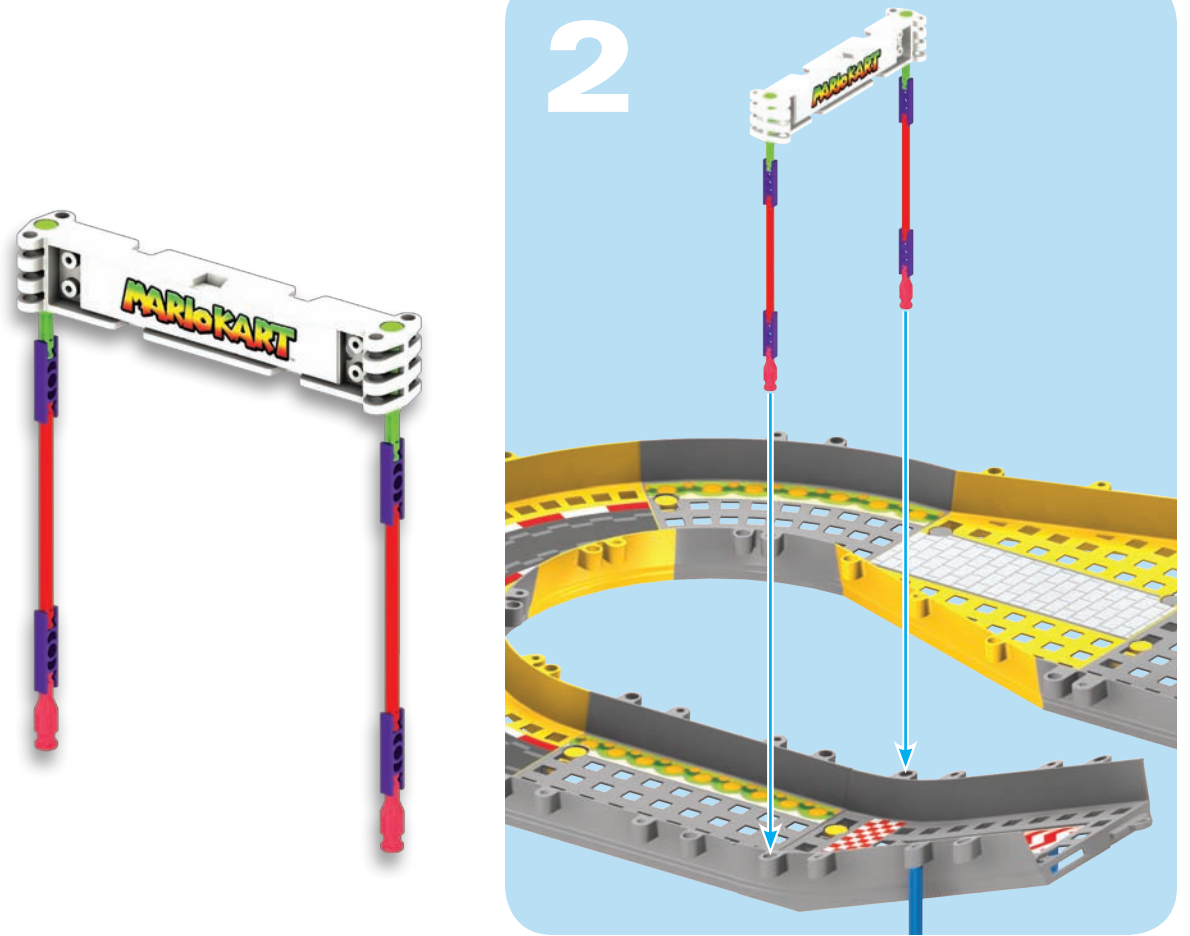

1

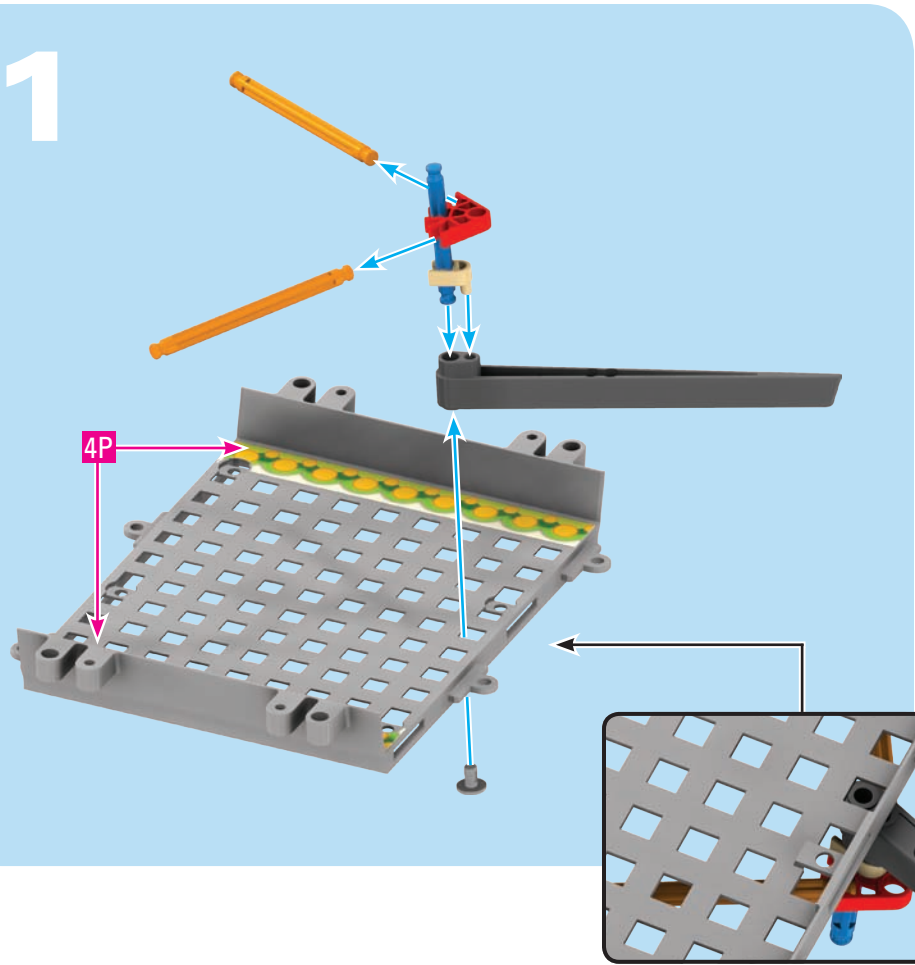

2

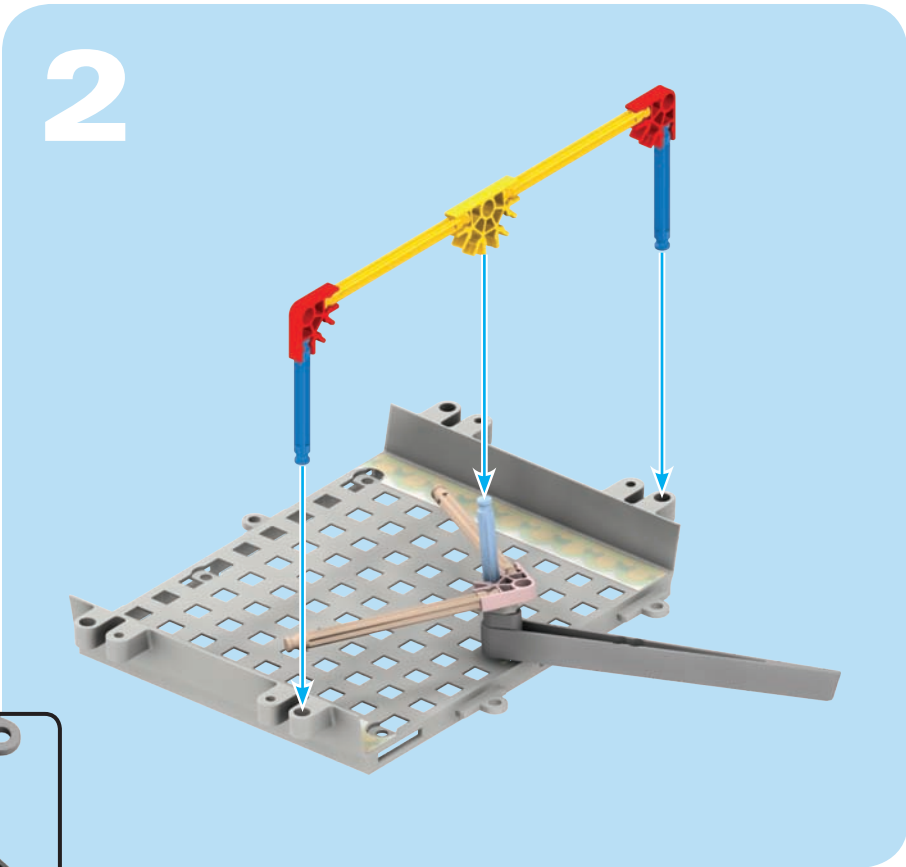

3

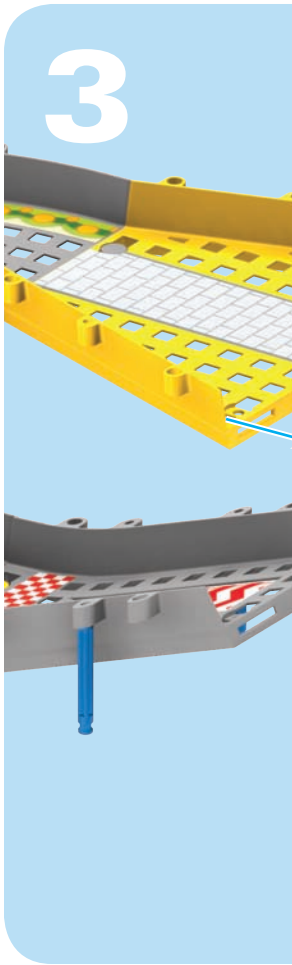

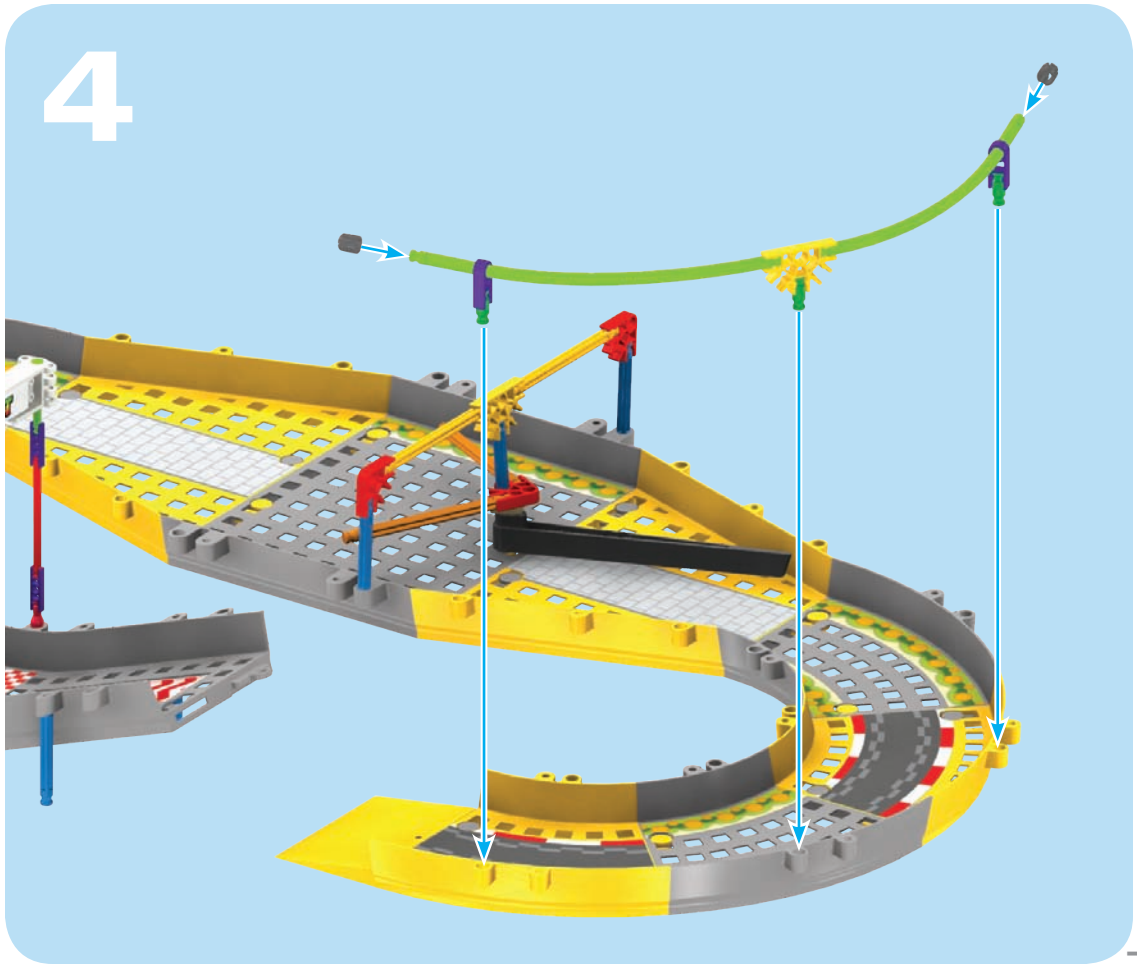
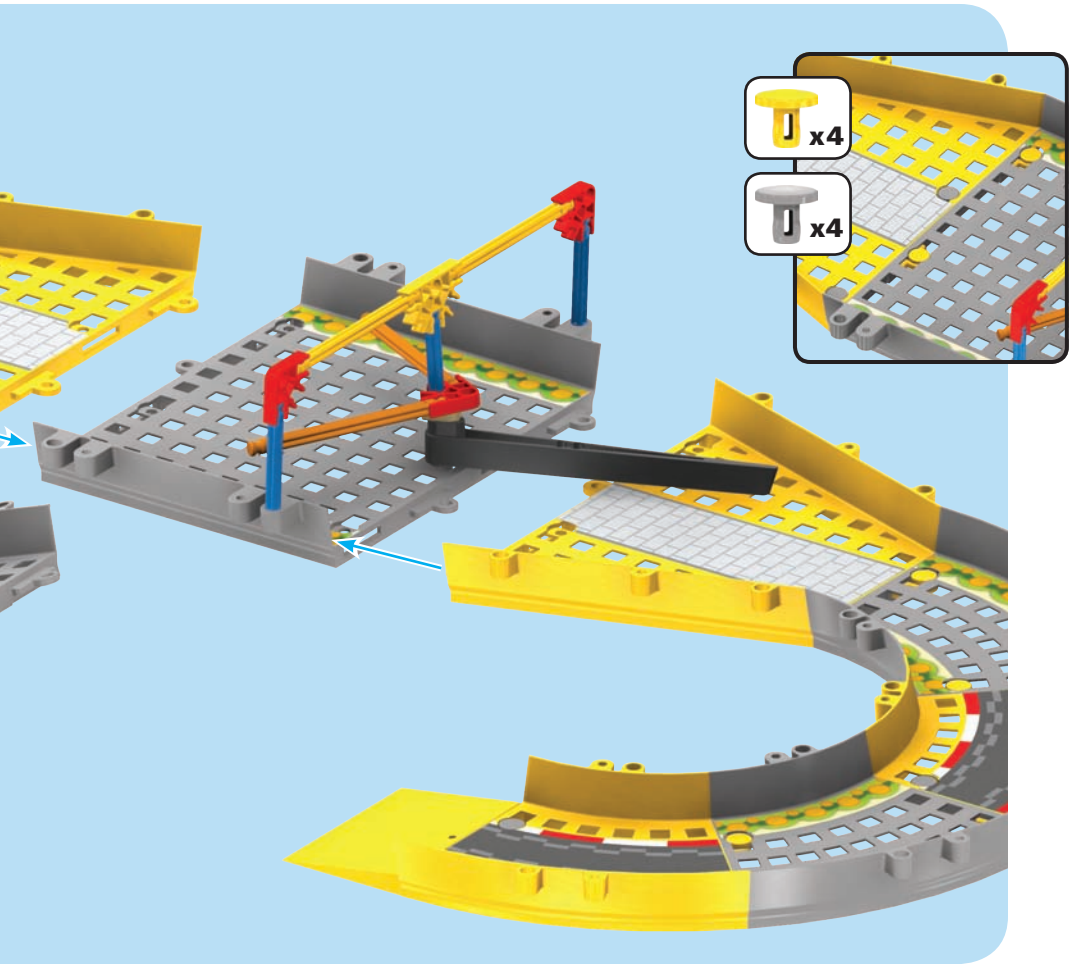
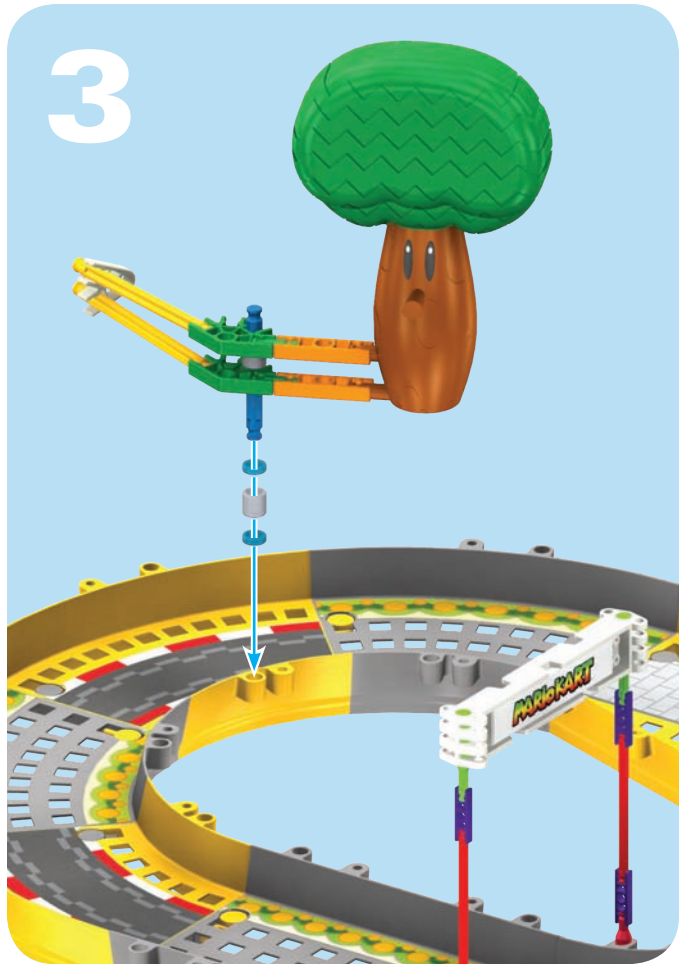
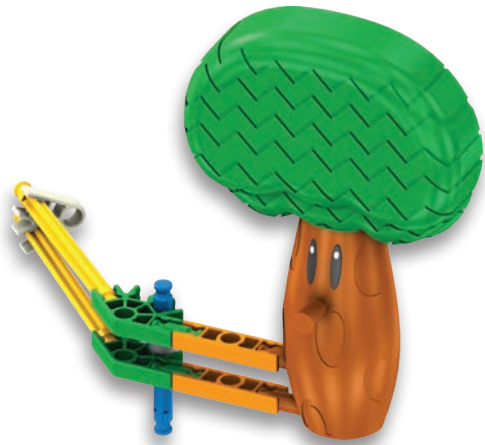
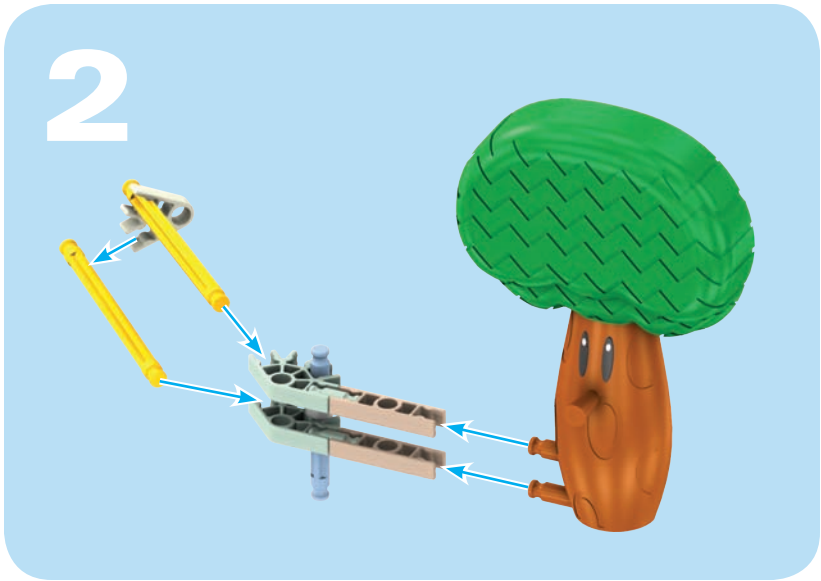
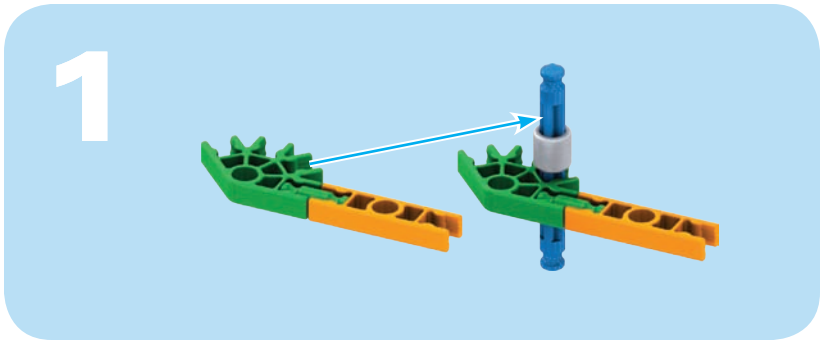

1

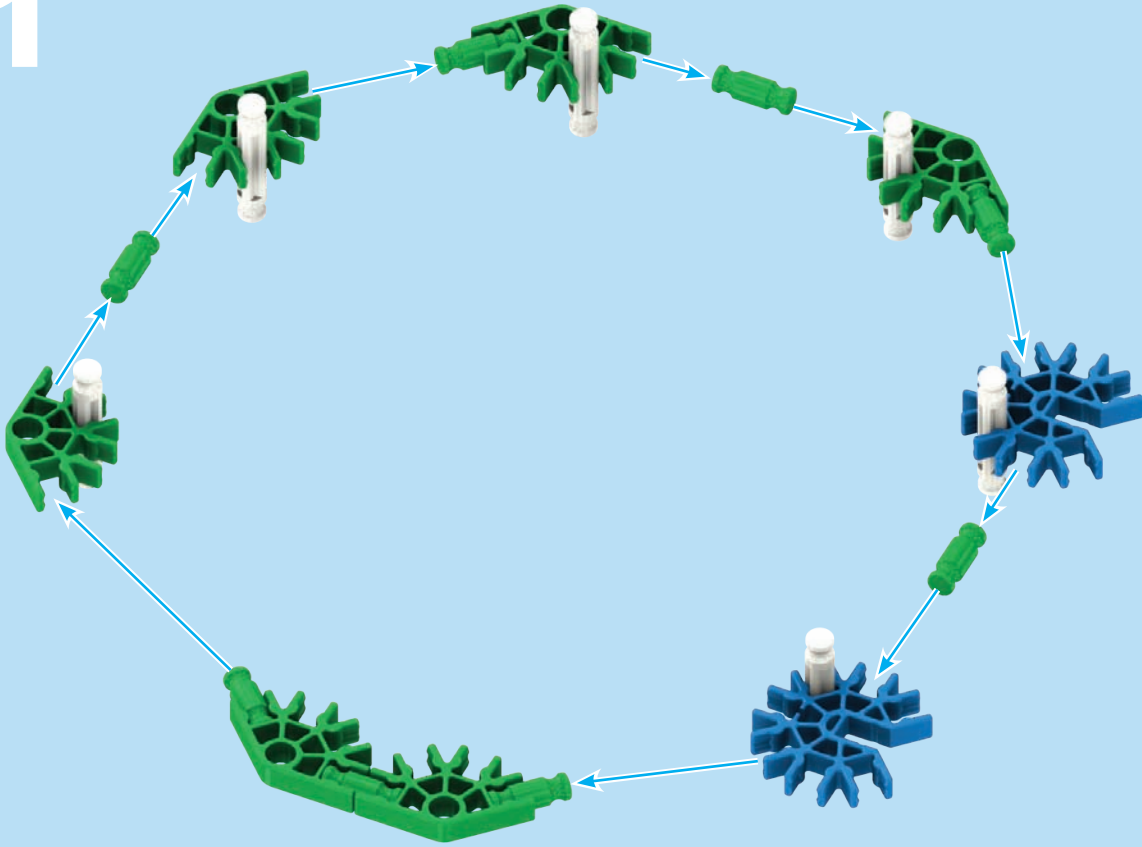

2

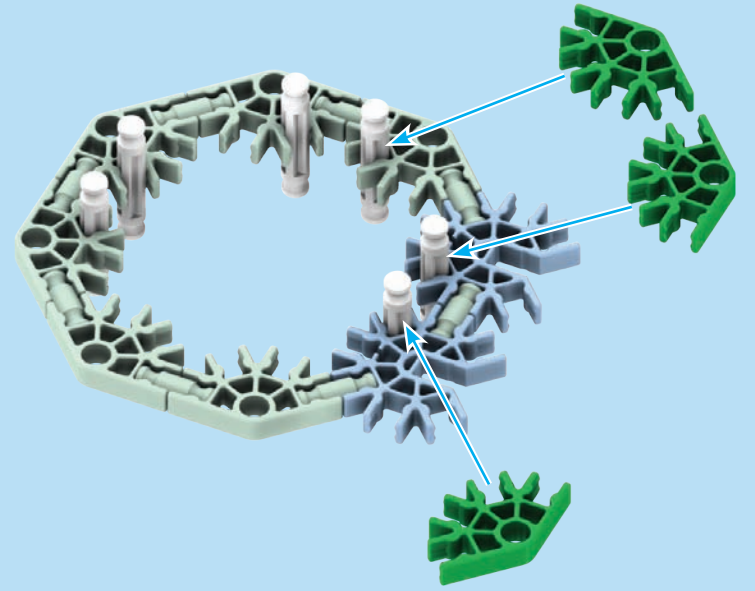

3

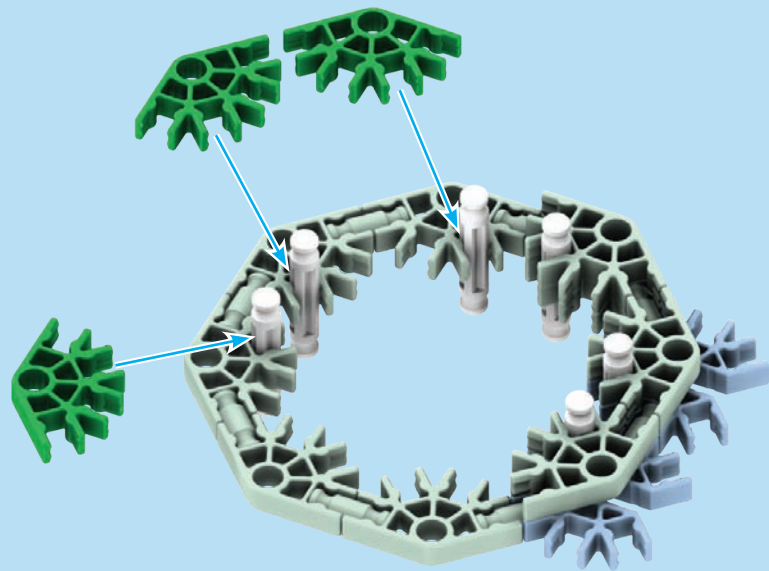

4

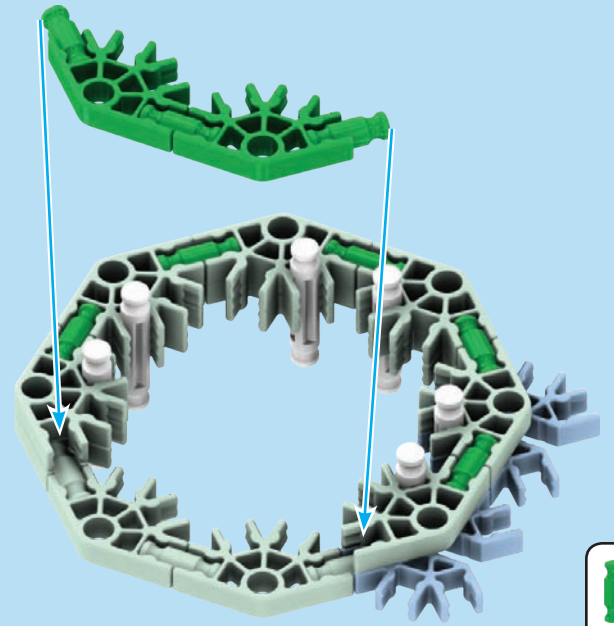

5

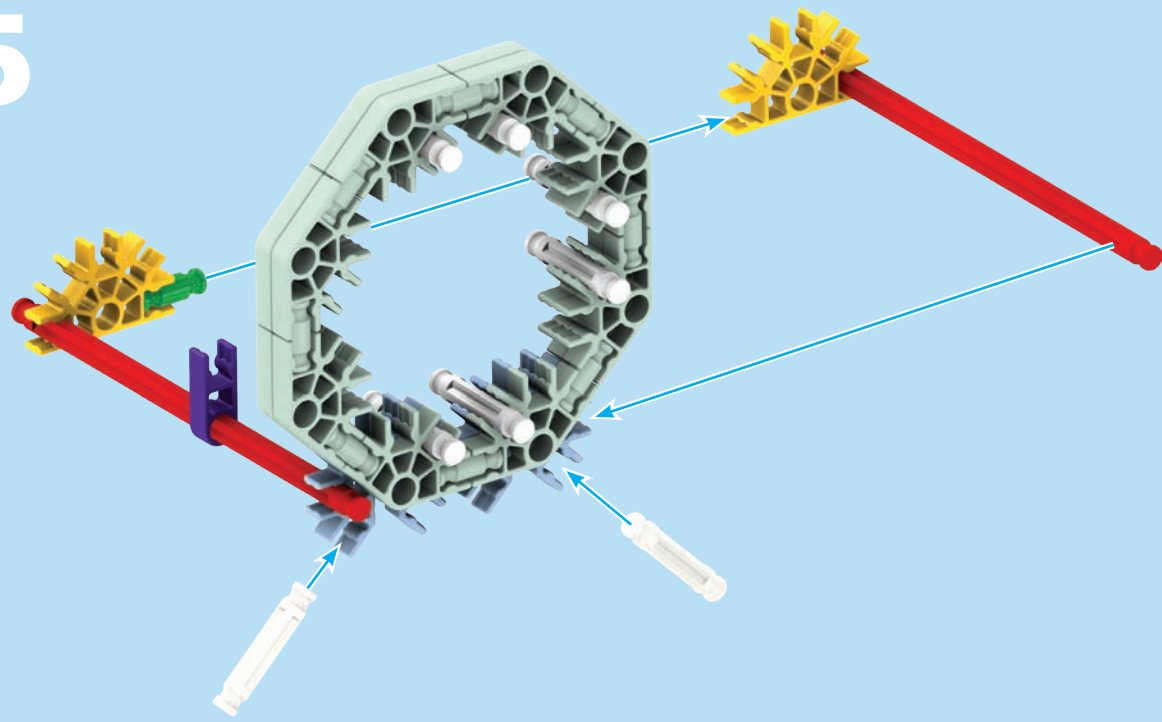

6

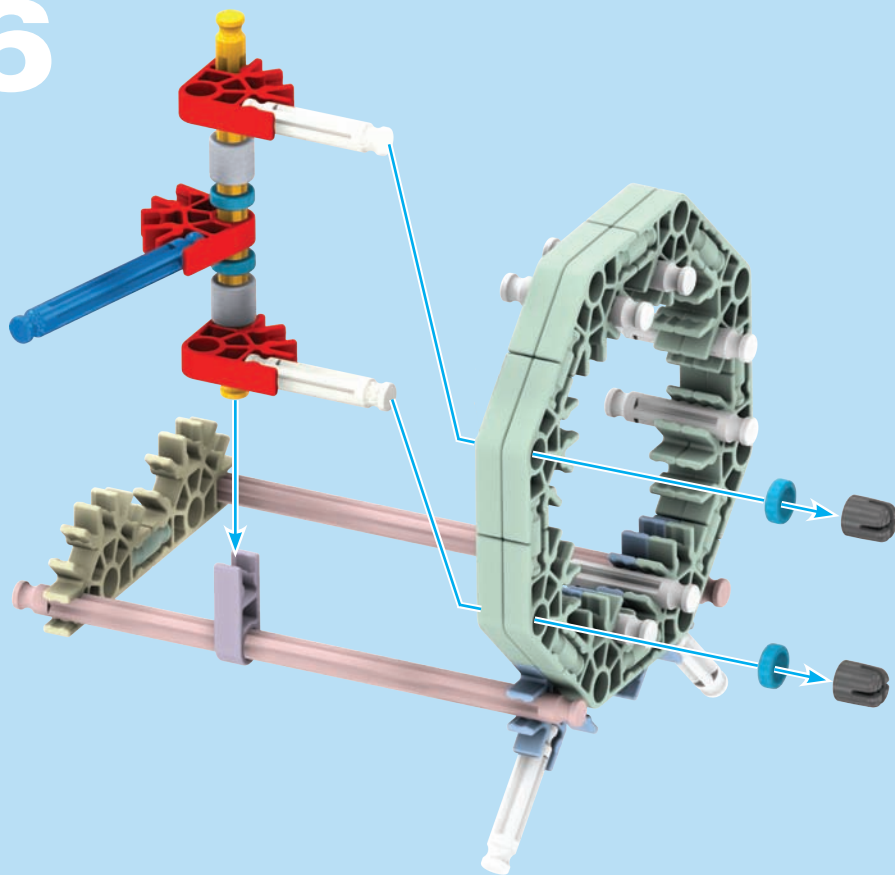

7

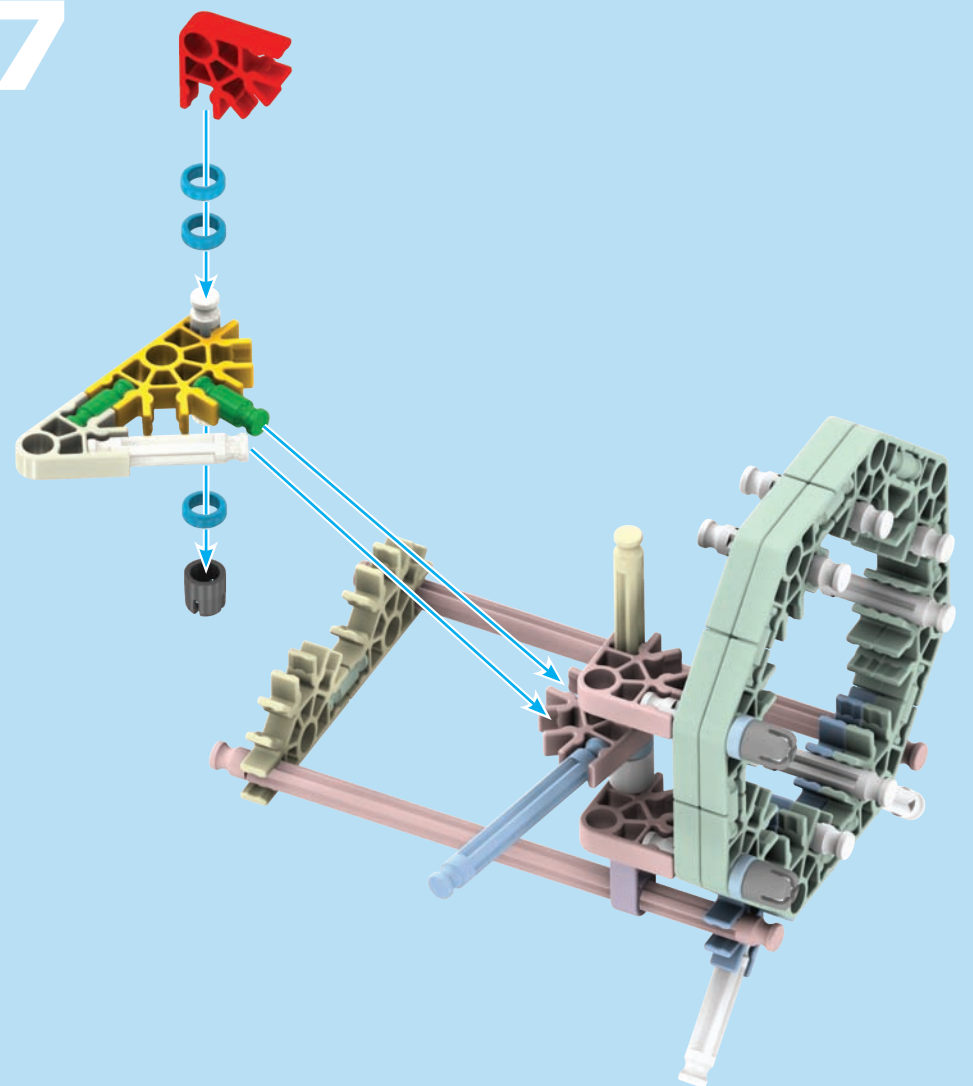

8

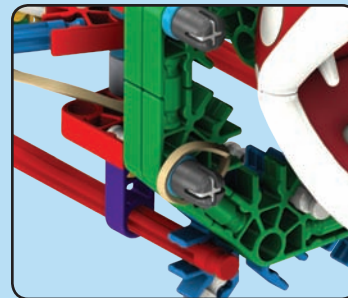
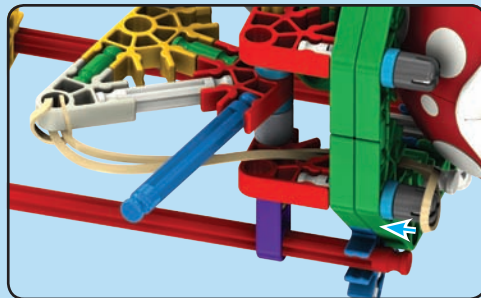
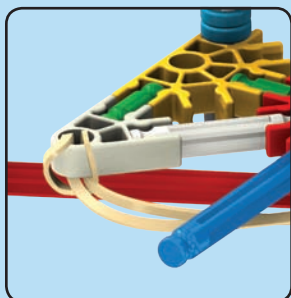
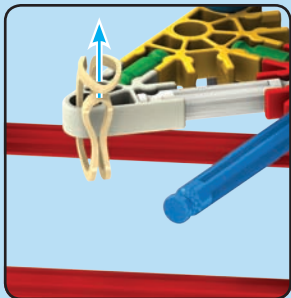
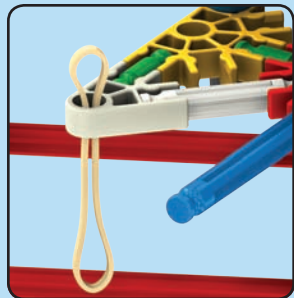
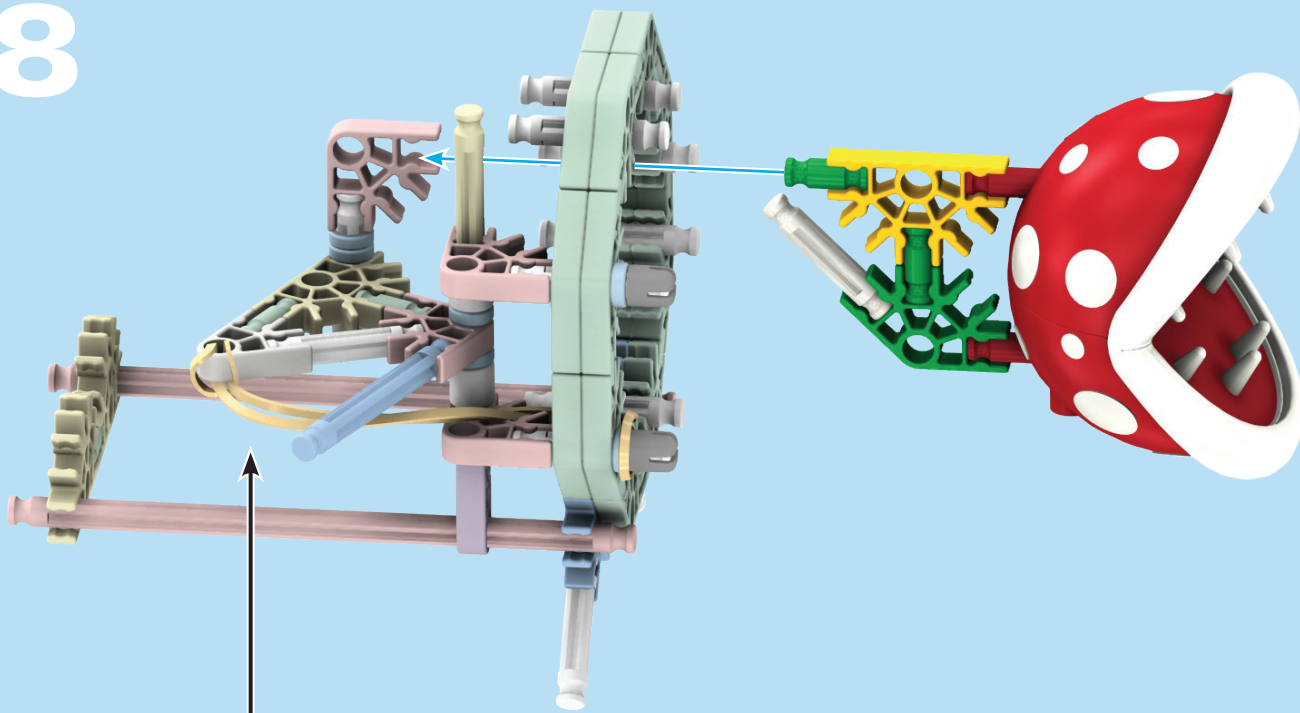

9



MARIO™ AND DONKEY KONG™ CIRCUIT START LINE BUILDING SET™

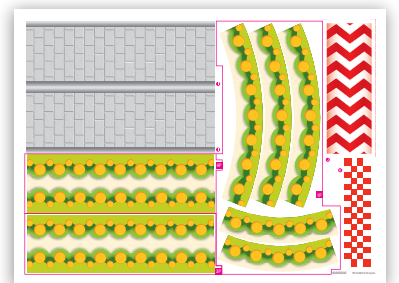
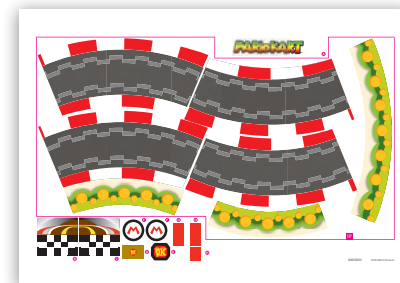
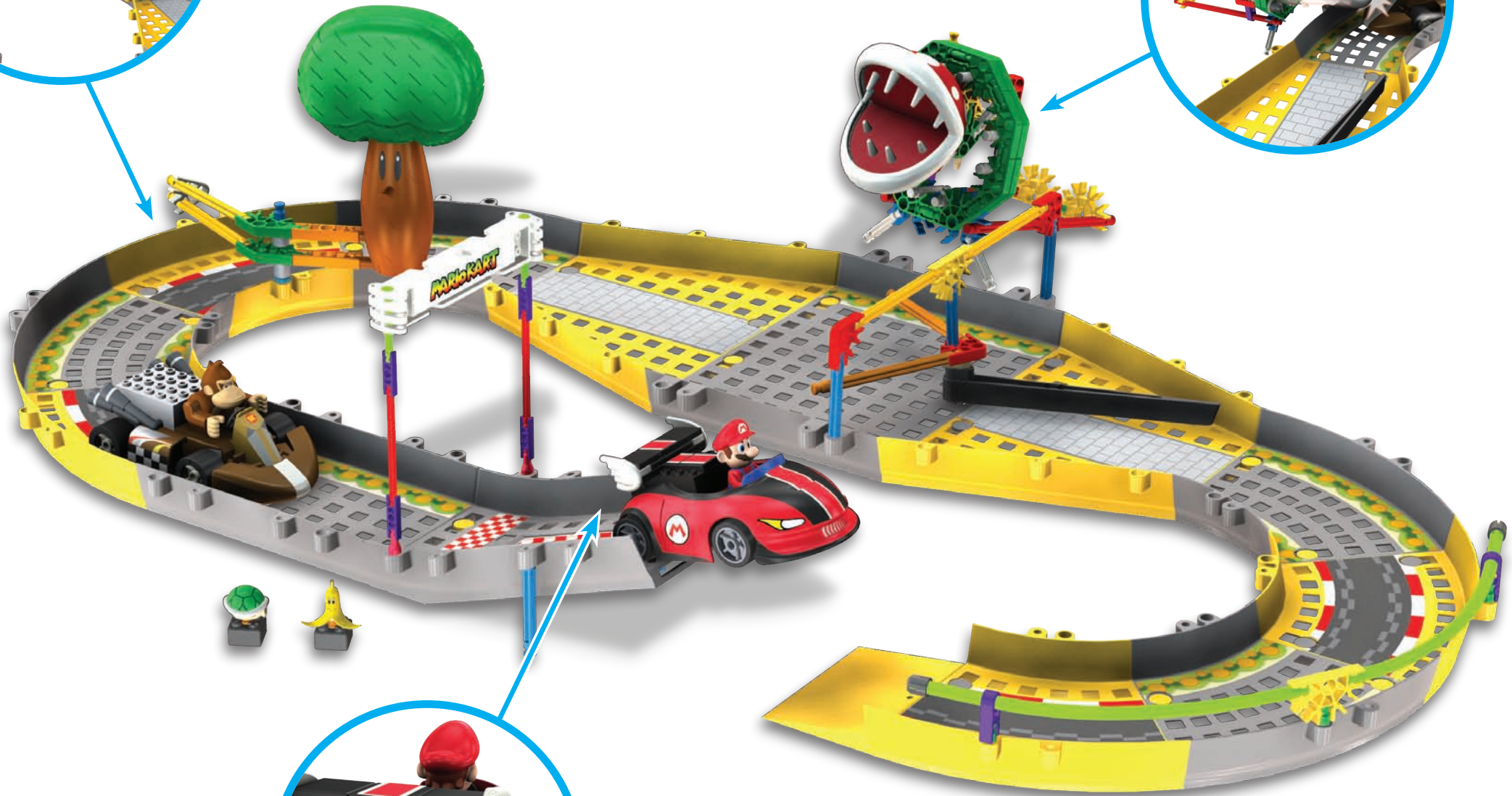
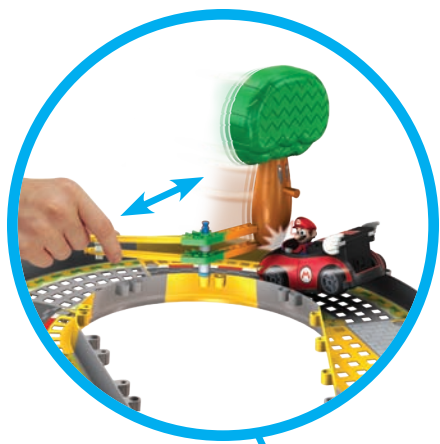

MARIOKART™ Wii

Collect all the Mario Kart™ Wii building sets to create your own tracks!
¡Recoja todos los sistemas del edificio de Mario Kart™ Wii para crear sus propias pistas!
Rassemblez tous les ensembles de bâtiment de Mario Kart™ Wii pour créer vos propres voies !

*Sold separately. Some products may not be available in all markets.
Se venden por separado. Algunos productos no pueden estar disponibles en todos mercados.
Vendus séparément. Certains produits ne sont pas disponibles pour tous les marchés.



TM & © 2012 Nintendo.

www.knex.com/mariokartwii



KNEX.COM

K'NEX is a registered trademark of K'NEX Limited Partnership Group. Product & colors may vary. (ES) K'NEX es una marca registrada de K'NEX Limited Partnership Group. El producto y los colores pueden variar. (FR) K'NEX est une marques déposée de K'NEX Limited Partnership Group. Produits et couleurs peuvent varier.

©2012 K'NEX Limited Partnership Group, P.O. Box 700, Hatfield, PA 19440-0700; email@knex.com; www.knex.com; 1-800-KID-KNEX (USA/EE.UU./États-Unis/Canada). Customer outside the USA & Canada contact your local distributor at www.knex.com/distributors. (ES) El cliente que no vive en EE.UU. y Canadá se pone en contacto con el distribuidor local. Encuentre la información para el distribuidor local en www.knex.com/distributors. (FR) Le Service clients hors États-Unis et Canada, s'il vous plaît contacter le distributeur local. L'information de distributeur peut être trouvée à www.knex.com/distributors. (DE)(FR)(NL)(UK) www.tomy.eu. (UK) TOMY Careline, PO Box 20, Totton, Hants, SO40 3YF, England; Tel 023 8066 2600. (FR) ALLO TOMY SAV, Parc d'affaires international, 74166 ARCHAMPS, France ; Tél 0 820 013 013.

- Identifies Genuine K'NEX Bricks.
- Identifica los ladrillos genuinos de K'NEX.
- Identifie que ce sont d'authentiques briques K'NEX.
- Identifiziert echte K'NEX-Bausteine.
- Edentifica i veri blocchi K'NEX.
- Identifica que são cubos genuínos da K'NEX.
- Identificeert K'NEX bakstenen voor.



facebook.com/buildknex

138350-V1-04/12

